

Power Electronic Thermal System Performance and Integration



**2009 DOE Vehicle
Technologies Annual
Merit Review**

Kevin Bennion

May 22, 2009

Project ID: ape_13_bennion

Presented at the 2009 U.S. DOE Hydrogen Program and Vehicle Technologies Program Annual Merit Review & Peer Evaluation Meeting held 18-22 May 2009 in Arlington, Virginia

NREL/PR-540-45794

This presentation does not contain any proprietary, confidential, or otherwise restricted information.

Overview

Timeline

- Project Start: FY 2007
- Project End: FY 2011
- Percent Complete: 50%

Budget

- Total Funding (FY07-FY09)
 - DOE: \$1,005K
 - Contract: \$0K
- Annual Funding
 - FY08: \$280K
 - FY09: \$375K

Partners/Collaboration

- Electrical and Electronics Technical Team (EETT)
- USCAR Partners
- Delphi

Barriers

- Cost (\$/kW)
- Specific Power (kW/kg)
- Power Density (kW/L)
- Efficiency
- Life

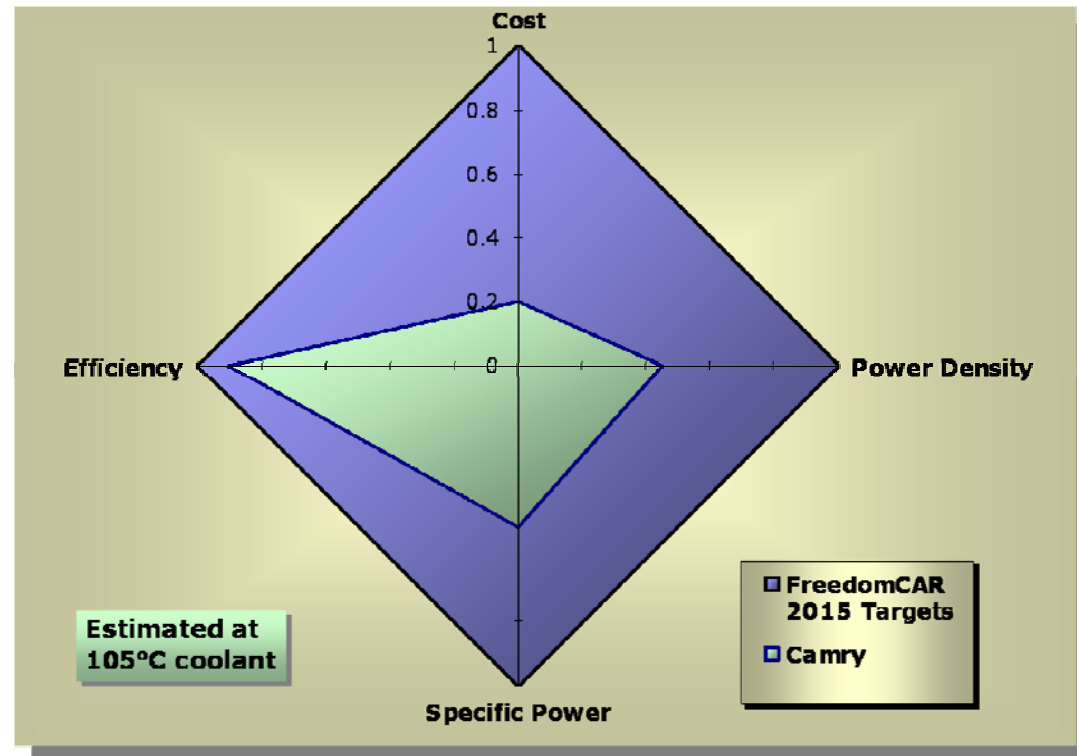

Objectives

- Facilitate the integration of APEEM thermal control technologies into commercially viable advanced automotive systems including hybrid electric, plug-in hybrid electric, and fuel cell vehicles

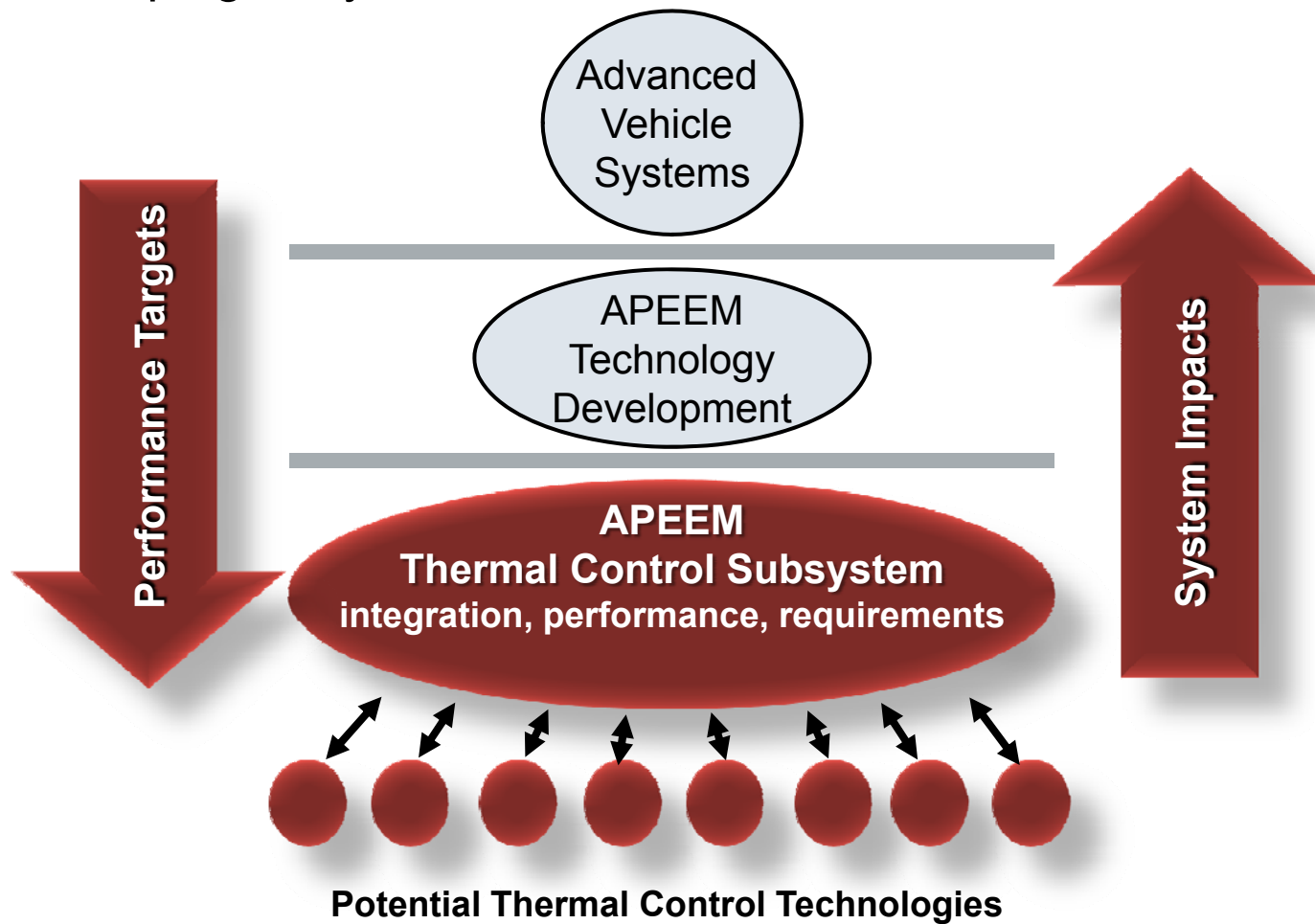

Objectives: Relevance

Thermal management directly relates to improvements in cost, power density, and specific power.

Prius PE MY 2004



Camry PE MY 2007

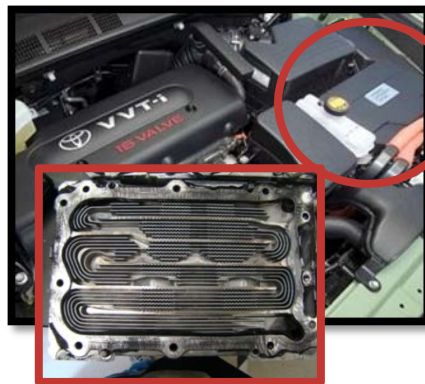

LS 600h PE MY 2008



Double-sided
Cooling

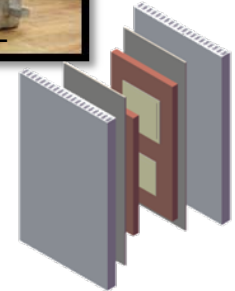

Impacts: Lower cost, volume, and weight

“easy ways to increase output power are paralleling more silicon chips and/or step-up the die size to increase current capacity. But this strategy is **unaffordable** in terms of both increased chip cost and packaging space”

Enabling technology : double-sided cooling package

“the most significant concern for increasing current is intensified **heat dissipation**”

Source: Yasui, H., et al, “Power Control Unit of High Power Hybrid System” – Denso and Toyota, EVS23

Milestones (FY08 & FY09)

FY08

Report on status and results of the thermal control technology R&D (September 2008):

- Developed an FEA parametric model and analysis techniques to characterize the thermal response of power semiconductor package designs.
- Developed techniques for characterizing vehicle drive profiles and PE thermal duty cycles in the frequency domain.
- Established industry relationships to study potential for double-sided cooling.

FY09

Evaluate cooling requirements for advanced power electronics topologies (June 2009).

Report on status and results of the thermal control technology R&D (September 2009).

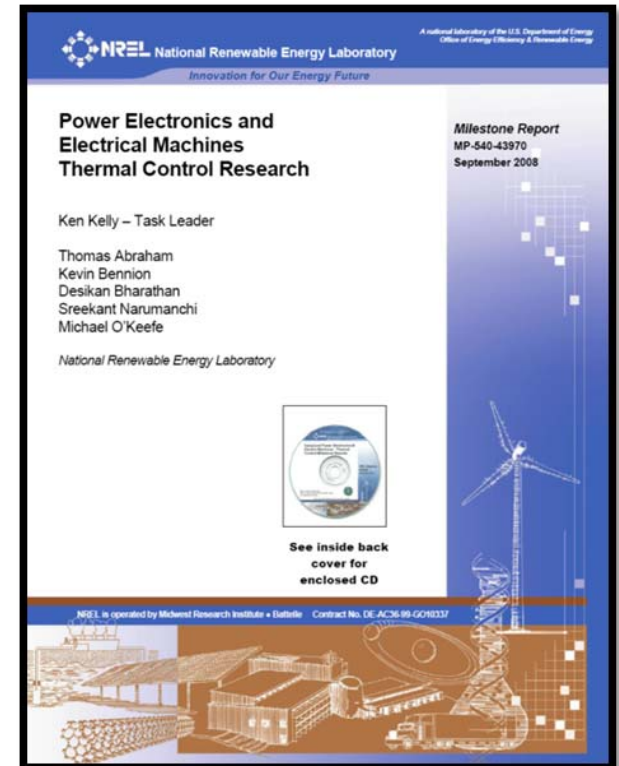

Approach

1) Evaluate Tradeoffs for Improved Thermal Management.

- Develop rapid screening tradeoff analysis tools.
 - Heat flux, heat exchanger performance, parasitic power.
- Evaluate application to advanced power electronic thermal management packages.
- Extend application to other critical components.

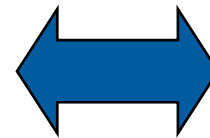
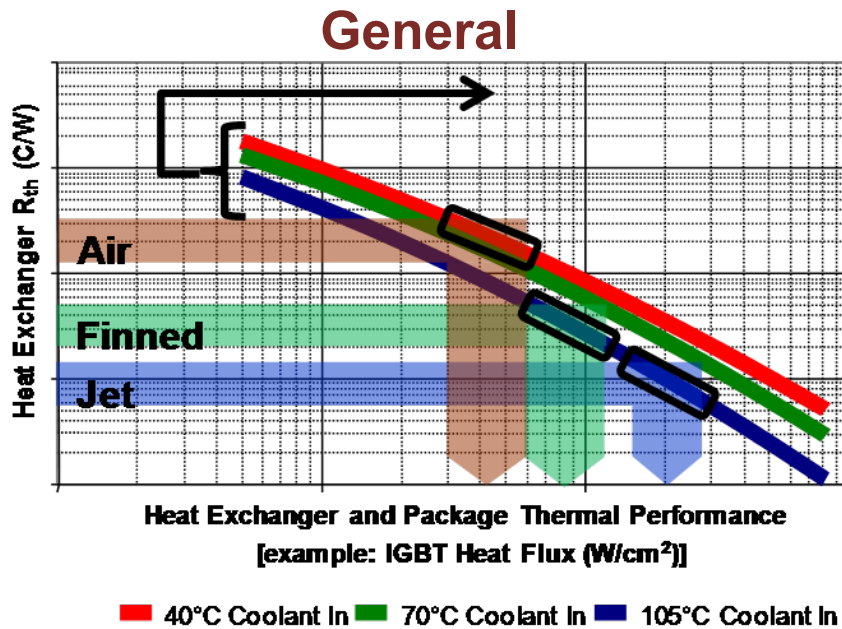

Specific

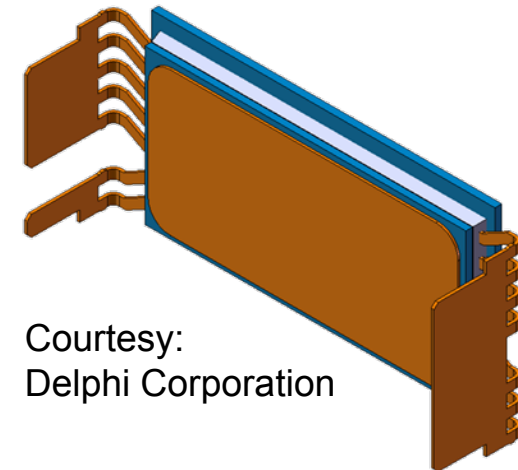

Why Important?

- Optimize thermal control package to meet performance targets.

Approach

2) Characterize Thermal Impedance and Dynamic Loading.

- Characterize transient thermal impedance for package configurations and cooling techniques.
- Utilize available in-use drive data from Vehicle Systems Analysis Technical Team to characterize in-use dynamic loading.

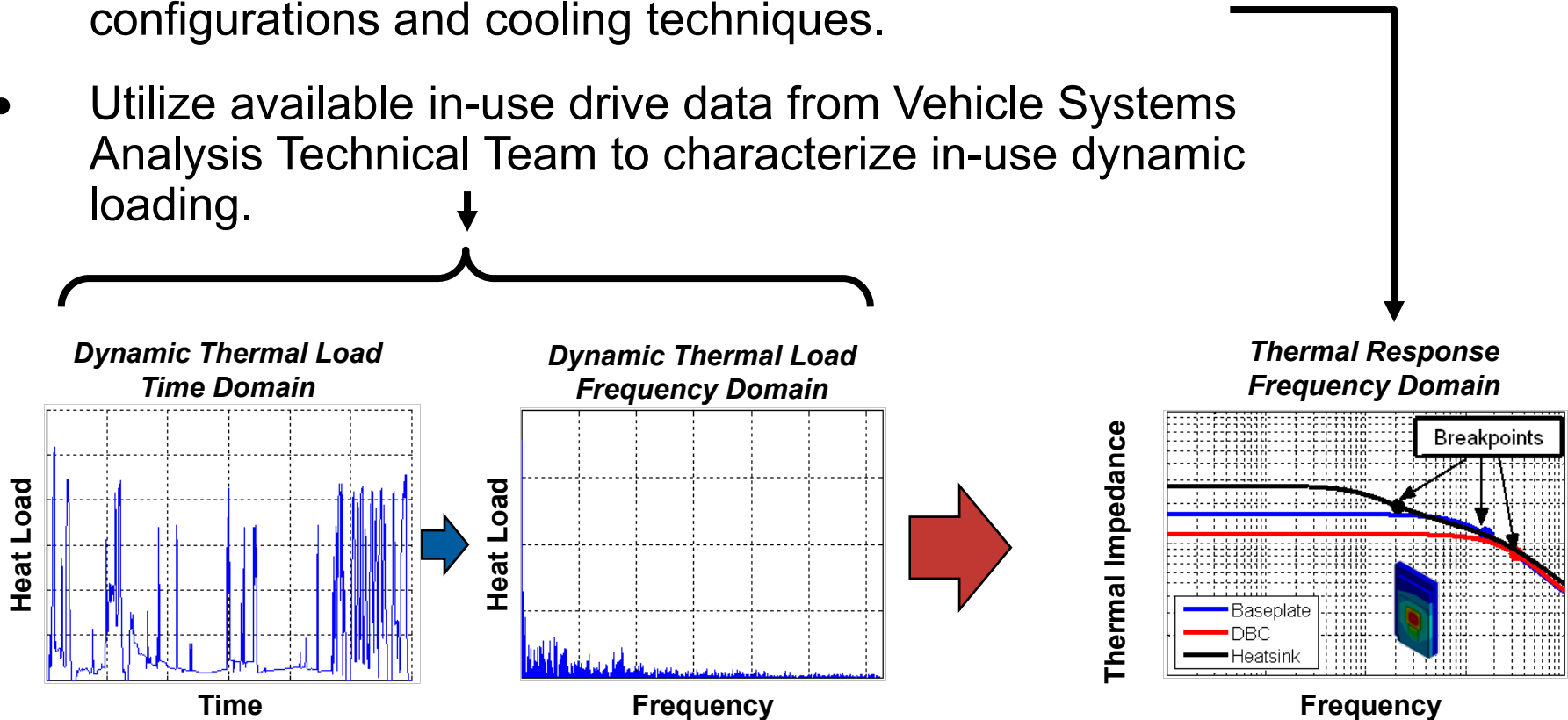

Why Important?

- Evaluate lightweight packages and support thermal stress and reliability comparisons.

Technical Accomplishments

Semiconductor Thermal Package Design Study

- Added new parametric 3D-FEA thermal modeling capability to understand the interactions between package topology, material selection, package size, and cooling technologies.
- Impact
 - Provides a modeling framework with the ability to simultaneously study the impacts of heat exchanger performance, material properties, and package geometry.
 - Integrates multiple avenues of thermal management technologies.

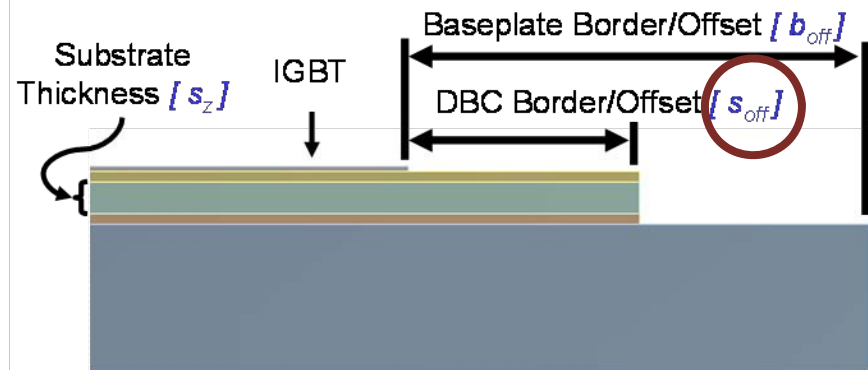
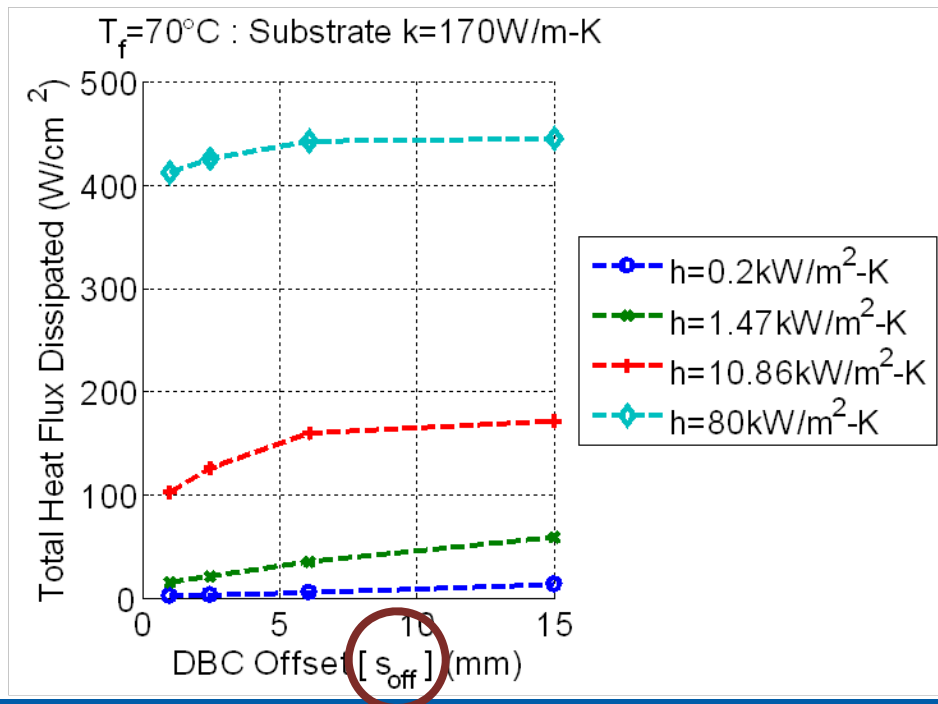

Notes: Listed offsets were applied around the IGBT and diode.
Items highlighted in brackets were variables in the analysis.

Technical Accomplishments

Semiconductor Package Thermal Performance Integration

Lexus LS 600h PE MY 2008

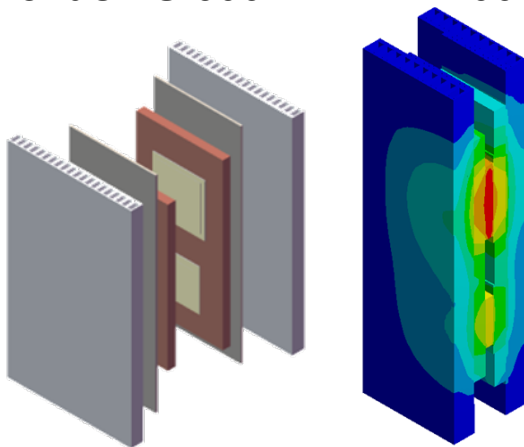

- Matches thermal performance to the desired application and matches the cooling strategy to the selected power module packaging configuration.
- Impact
 - Meets the need to rapidly screen and compare multiple packaging and thermal management options.
 - Rapidly evaluates trade-offs associated with alternative packaging configurations and thermal management technologies.
 - Includes the integration of available experimental correlations, computational fluid dynamics results, parametric 3D FEA thermal models, and established heat exchanger analysis techniques.
 - Brings industry feedback into developed analysis techniques through close industry interaction.

Alternative Double-sided Cooling Packages

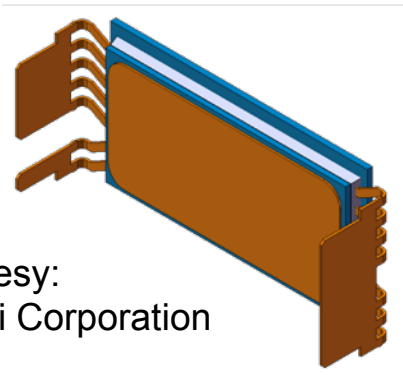

Courtesy:
Delphi Corporation

Continued on Next Slide

Technical Accomplishments

Semiconductor Package Thermal Performance Matching (Example)

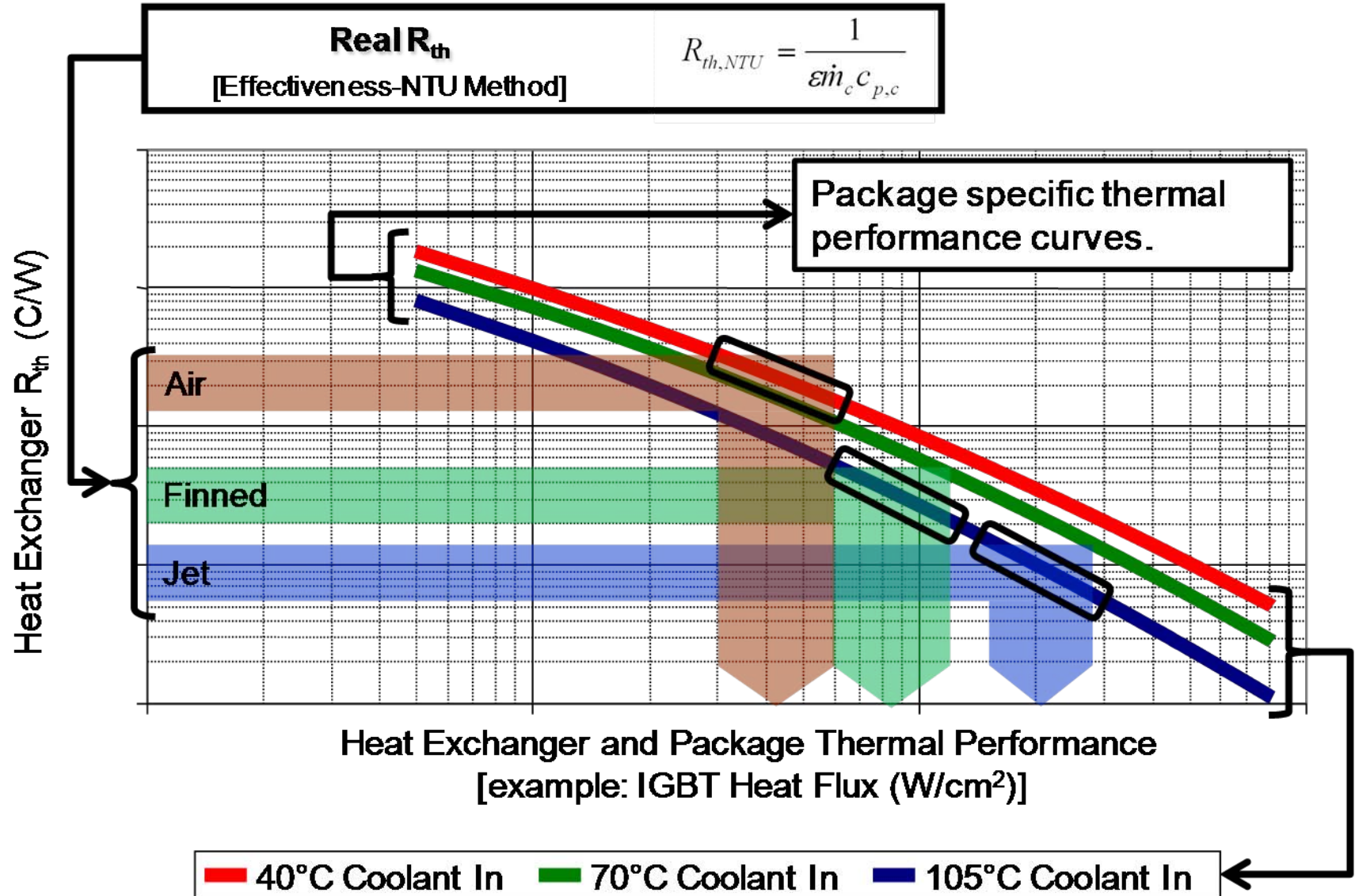

Technical Accomplishments

Power Electronics System and Capacitor Thermal Analysis

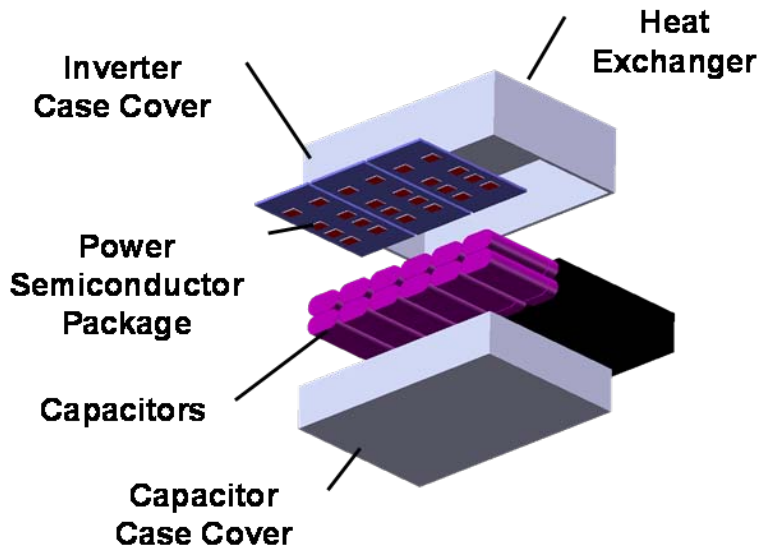

- Developed a parametric finite-element model for thermal control of power electronics at the module level.
- Impact
 - Includes thermal impact of key supporting components.
 - Performed preliminary investigation into the impacts of coolant temperature, heat exchanger performance, and capacitor cooling on the capacitor temperature profile.
 - Supports future work at system level.

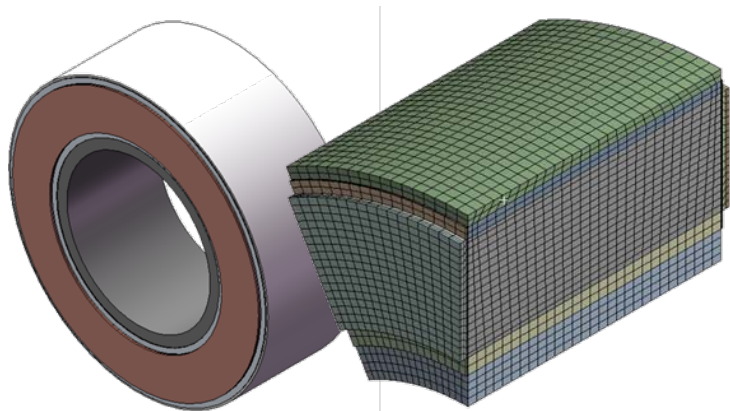

- Developed parametric finite-element capacitor thermal model.
 - Variable CAD Geometry.
 - Variable material properties and boundary conditions.
- Impact
 - Supports future work related to capacitor thermal management.

Technical Accomplishments

Package Transient Response Characterization

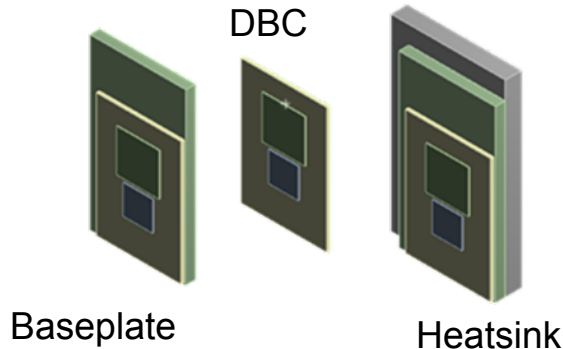

- Demonstrated a method for comparing transient thermal impedance based on the frequency response of the power semiconductor package.
- Impact
 - Transient thermal impedance impacts package reliability.
 - Links the thermal duty cycle load in the frequency domain to the frequency response of the package.
 - Enables rapid transient simulations and quick qualitative comparisons.
- Future
 - Augment the technique through improved hardware validation and investigate how different cooling techniques impact the transient thermal response.

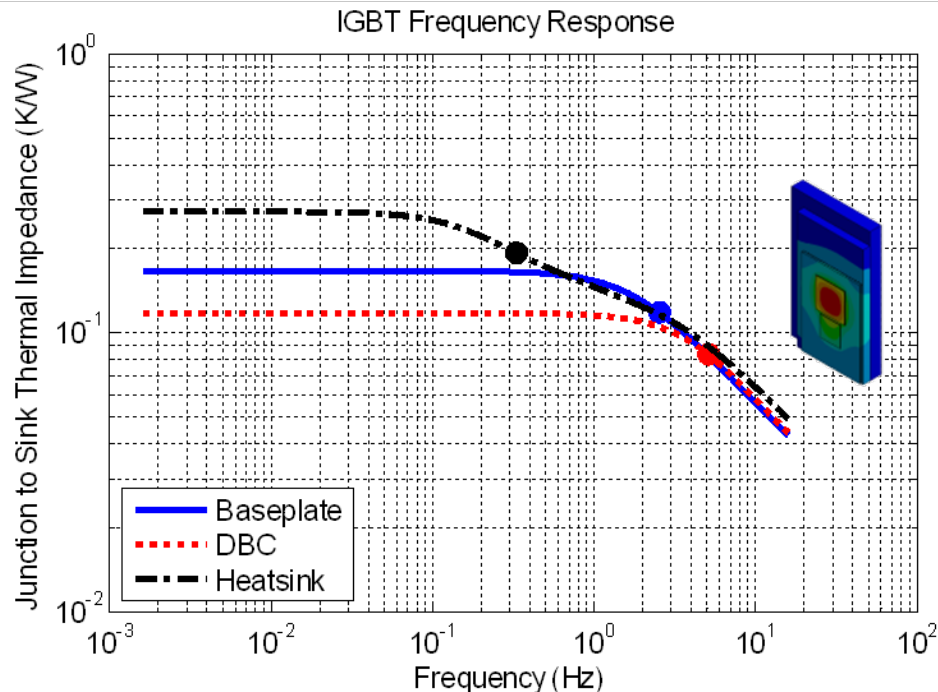

Future Work

- Apply modeling methodology to develop innovative thermal management package for power electronics applications enabling reductions in cost, weight, and volume targets.
 - Apply techniques to DOE and industry development technologies and leverage partner data to validate process.
- Improve research and development tasks related to thermal management technologies.
 - Research targets.
 - Integrate technologies.
 - System Impacts.
- Evaluate integration of power electronics thermal management system within a larger vehicle thermal management system context.
 - Leverage Vehicle Systems Analysis and Energy Storage groups.

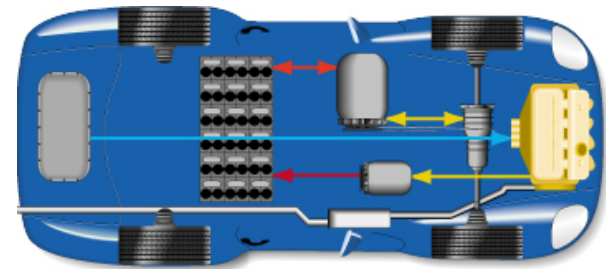

Summary

System Thermal Performance and Integration is a Multi-Dimensional Problem



Vehicle Type

HEV/PHEV
FCV

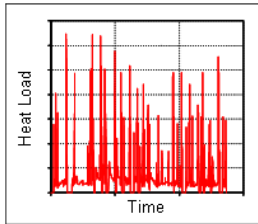

Component Use

Peak
Continuous
Dynamic

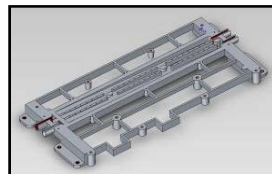

Cooling System

Coolant Temperature
Convection Coefficient
Heat Exchanger Effectiveness

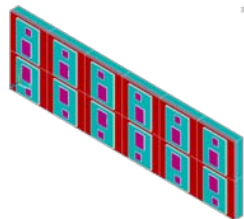

PE Package

Topology
Materials

- Accomplishments address multi-dimensional aspect of problem.
- Work is supported by industry and benefits from close industry interaction.
- Deliverables support and improve existing research and development efforts.
- Plan for future work leverages existing activities at DOE and industry partners.

Publications and Presentations

FY08

- DOE Milestone: “Report on status and results of the thermal control technology R&D.” September, 2008.

FY09 (Planned)

- DOE Milestone: “Evaluate cooling requirements for advanced power electronics topologies.” June, 2009.
- DOE Milestone: “Report on status and results of the thermal control technology R&D.” September, 2009.
- Conference Paper: “Rapid Modeling of Power Electronics Thermal Management Technologies.” 5th IEEE Vehicle Power and Propulsion Conference, 2009. (Paper in Progress).

Critical Assumptions and Issues

- The thermal performance of a particular power electronics application is not only dependent on the heat exchanger design and technology. The performance is also a function of the power electronics packaging. The optimal or robust heat exchanger technology depends on the overall package layout.
 - For this reason continuous collaboration with industry, laboratory, and university partners is needed related to new developments in power electronics packaging to ensure evaluation of the latest available package technologies.
- Assumptions related to available coolant temperatures have a significant impact on program targets and influence the direction of selected research and development projects.
 - There is a need to investigate alternative cooling configurations based on vehicle propulsion type, which will enable performance targets and research and development targets that fit within an overall integrated vehicle thermal management package.