

BETO 2021 Peer Review: Biological Upgrading of Sugars (BUS) 2.3.2.105

Jeff Linger
NREL
Biochemical Conversion
March 8, 2021

Project Overview

In FY17 the BUS project began developing an **integrated and scalable process for the production of carboxylic acids** as biologically derived intermediates with a recent emphasis on butyric acid which our partners are catalytically upgrading to hydrocarbon fuels.

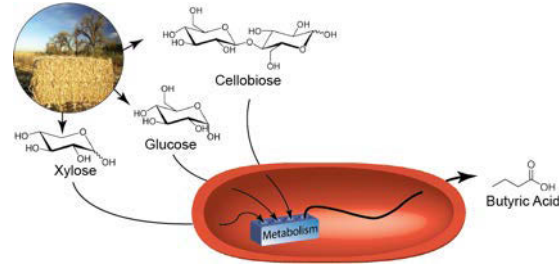

- **What are we trying to do:** Target anaerobically-derived biological intermediates that can be used as precursors to the production of Jet and Diesel blendstocks.
- **How is it done today and what are the limits:** Most butyric acid is petroleum-derived. Biobutyric acid faces economic challenges that have ample room for improvement.
- **Why is it important:** Our strategy is heavily guided by TEA and LCA analysis. We have developed a research and scaling pathway to enable cost effective biofuel production.
- **What are the Risks:** Failure to meet specific TRY metrics, unforeseen challenges with scaling. *Accordingly, these risks are assessed on an annual basis.*

Project Overview



Terrestrial Biomass to Drop-In Jet and Diesel Fuels
Using butyric acid as a biological intermediate.

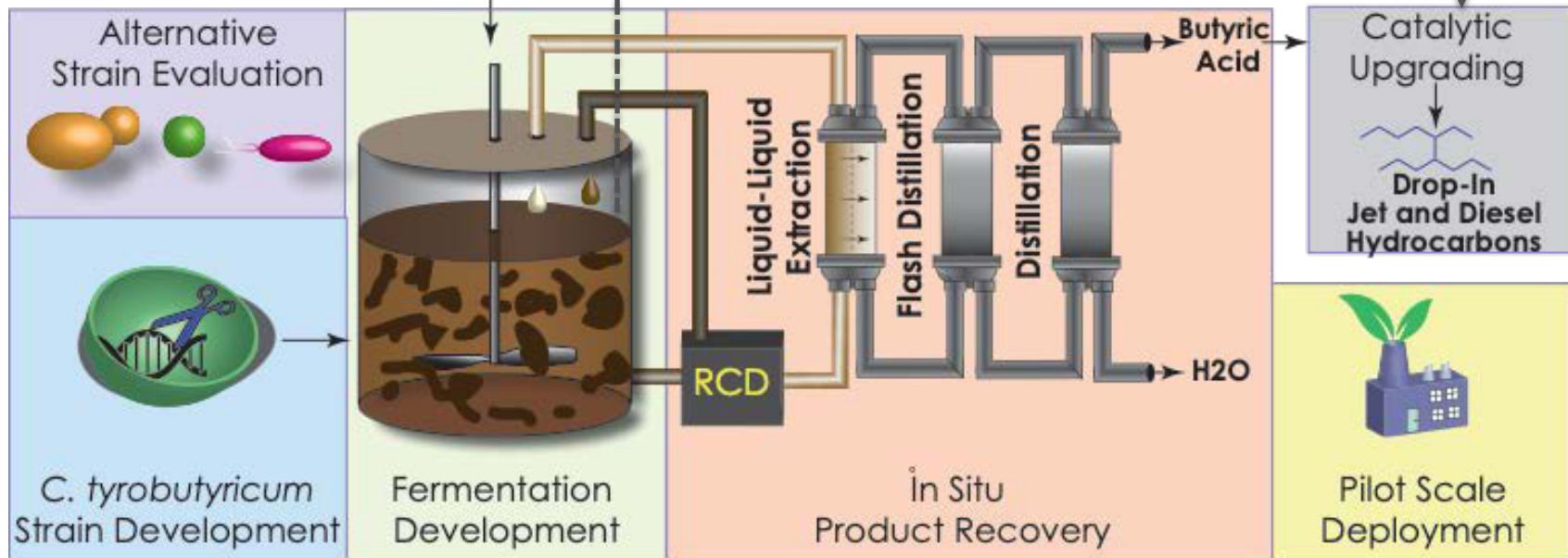

Overview - Catalytic Upgrading of Anaerobically Produced Acids

Carboxylic Acids Upgrading Platform

Hybrid technology applicable to anaerobic acids derived from lignocellulosic sugars, as well as mixed acids derived from wet waste

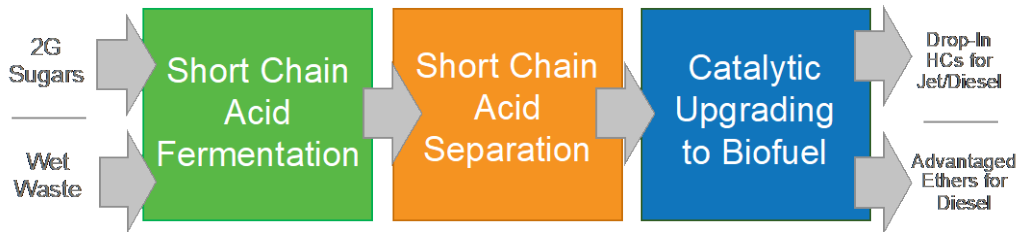

Drop-In C14 Isoparaffin for Diesel & Jet

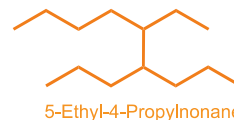

Advantaged C11 Ether Diesel Blendstock

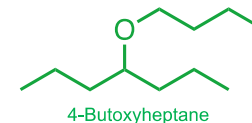

Property	Fossil Diesel	C14 HC
Energy	45 MJ/kg	44 MJ/kg
Freeze pt	- 10 °C	< - 80 °C
Flash pt	55 °C	74 °C
Cetane	47	48
Soot YSI	215	98

Property	Fossil Diesel	C11 Ether
Energy	45 MJ/kg	39 MJ/kg
Freeze pt	- 10 °C	< - 80 °C
Flash pt	55 °C	74 °C
Cetane	47	80
Soot YSI	215	58

Neat Acid Ketonization



- Near theory 100-h yield on bio-acids
- Coking <3 wt% during partial conv 72 h
- No showstoppers for kinetic/Rx model

Ketone Elongation - HC

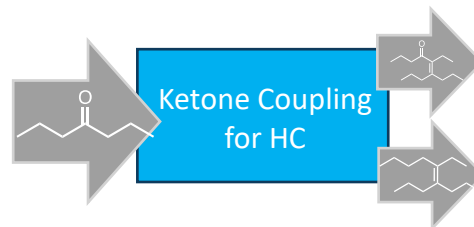

- Modeled as CSTR condensation
- Batch demo w/ recycle and regen
- Exploring chemistries for flow Rx

Ketone Elongation - Ether





- Developed bifunctional Pd/NbOPO₄
- Flow Rx >72 h on model feed w/regen
- Rate increases with Pd NP size

(Derek Vardon)

Market Trends

Product

 Gasoline/ethanol demand decreasing, diesel demand steady

 Increasing demand for aviation and marine fuel

 Demand for higher-performance products

 Increasing demand for renewable/recyclable materials

Feedstock

 Sustained low oil prices

 Decreasing cost of renewable electricity

 Sustainable waste management

 Expanding availability of green H₂

 Closing the carbon cycle

Capital

 Risk of greenfield investments

 Challenges and costs of biorefinery start-up

 Availability of depreciated and underutilized capital equipment

Social Responsibility

 Carbon intensity reduction

 Access to clean air and water

 Environmental equity

NREL's Bioenergy Program Is Enabling a Sustainable Energy Future by Responding to Key Market Needs

Value Proposition

- The BUS project directly targets the anaerobic conversion of lignocellulosic feedstocks into cost-competitive intermediate molecules readily upgradeable to sustainable aviation fuel, diesel blendstocks, and high value chemicals.

Key Differentiators

- Novel *In Situ* Product Recovery reduce major cost drivers in traditional product separation and purification routes.
- Pilot Scale Demonstration will reduce risks associated with scale-up.
- All process aspects are TEA-driven.

Quad Chart

Timeline

- Active Project Duration: 10/1/2020 – 9/30/2023
- Total Project Duration: 10/1/2017 – 9/30/2023

	FY20	Active Project (FY21-23)
DOE Funding	\$1,512,000	\$2,850,000

Project Partners-Collaborators: Separations Consortium, LANL, Biochemical Analysis Platform, Feedstock Conversion Interface Consortium, Arrested Anaerobic Digestion, Agile Biofoundry, ORNL (R. Hettich), ChemCatBio-CUBBI (D. Vardon), CBI (Y. Bomble).

Barriers addressed

- Ct-D Advanced Bioprocess Development
- Ct-L Decreasing Development Time for Industrially Relevant Microorganisms
- Ct-O Selective Separations of Organic Species

Project Goal

Develop microbial lignocellulosic conversion processes to enable production of fuels at the BETO goal of \$2.50 by 2030.

End of Project Milestone

Demonstrate the production of >10kg of Butyric Acid at >98% purity from DMR-EH utilizing glucose, xylose and arabinose with a productivity of 0.75 g/L/h and a yield of 0.55 g/g sugars, enabling a modeled cost below \$3/GGE.

Funding Mechanism

Bioenergy Technologies Office FY21 AOP Lab Call (DE-LC-000L079) – 2020

1. Management-Task Structure and Collaborations

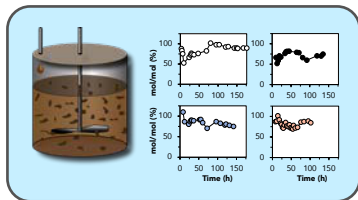

Fermentation Development (Davinia Salvachua)

- Developing Bench-Scale processes

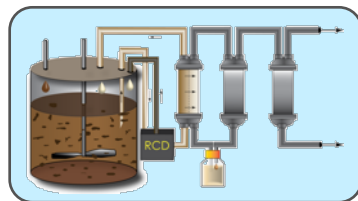

In Situ Product Recovery & Pilot Process Development (Eric Karp)

- Improving butyric acid separations
- Design & commission pilot scale reactor

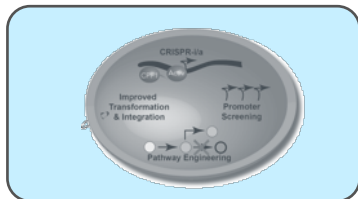

Strain Improvement (Michael Guarnieri)

- Increase butyric acid productivity from biomass at pH 5.0 or lower



Alternative Strain Evaluation (Violeta Sanchez i Nogue)

- Evaluate potentially superior hosts

Internal Collaborations:

- Separations Consortium-2.5.5.502
- Biochem. Platform Analysis-2.1.0.100
- Feedstock Conversion Interface Consortium (FCIC)-1.2.2.805
- Arrested Anaerobic Digestion-2.3.2.107
- ChemCatBio-Catalytic Upgrading of Biological Intermediates-2.3.1.101
- Center for Bioenergy Innovation (Dr. Yannick Bomble).

External Collaborations:

- Agile BioFoundry (Dr. Adam Guss)
- Oak Ridge National Lab (Dr. Robert Hettich)

1. Management-Communications

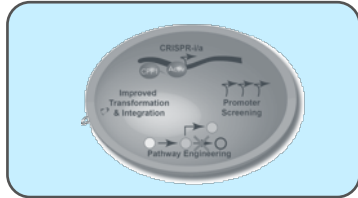
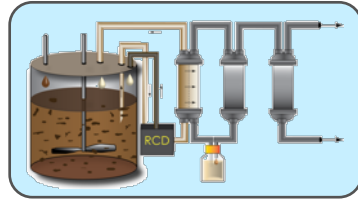
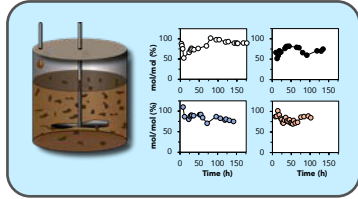

- Regular biweekly group meetings and strategy discussions.
- Frequent communications (~quarterly) with Biochemical Platform Analysis group for Technoeconomic analysis and risk identification.
- Delivery of Annual State of Technology Updates to ensure progress towards 2030 goals. Highlights technical areas in need of strategy mitigation.
- Regular communication with DOE, as well as internal and external collaborators.

2. Approach

General Approach

- Evaluate and down-select promising butyrate strains
- Optimize fermentation conditions to maximize butyrate TRY metrics
- Leverage strain improvement strategies to improve productivity at low pH
- Develop advanced separations methods and pilot scale processes

Challenges

- Reduced productivity at pH 5 (necessary for efficient butyrate extraction in organic solvents)
- Organic extractant has moderate toxicity
- Presence of xylose reduces fermentation times

Major Milestones Go/No-Go decisions

- **9/30/2021 Annual Milestone:** Complete the construction of a pilot scale reactor
- **03/31/2022 Go/No-Go:** Demonstrate the production of >10 kg Butyric Acid at >98% purity from DMR-EH corn stover hydrolysate.
- **09/30/2023 End of project:** Demonstrate the production of >10kg of Butyric Acid from DMR-EH from both glucose, xylose and arabinose with a productivity of 0.75 g/L/h and a yield of 0.55 g/g sugars.



3. Impact

- Butyric acid is primarily produced from the oxidation of butyraldehyde obtained from oxosynthesis of propylene (80,000 Tons/year). **Improving the economics of renewable routes can reduce dependence on petroleum-derived butyric acid.**
- Butyric acid represents a key intermediate towards catalytic fuel production wherein a C₁₄ bioblendstock has recently been demonstrated to exceed diesel property targets. **There are direct proven routes towards generating biofuels from butyric acid.**
- Butyrate production cost from lignocellulose represents ~50% of the current selling price. **Novel Hybrid Extraction-Distillation approach has reduced total process costs by 80% compared to traditional LLE approaches with back extraction.**



Drop-In Hydrocarbon Fuels

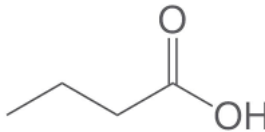

Specialty Chemicals & Materials

3. Impact

- Pilot-Scale demonstration of integrated process from raw feedstock to finished product in FY21-FY22 will serve as the **foundation for discussions with commercial partners.**
- Integration of Progressing Cavity Pump and a Rotating Ceramic Disk Filtration unit will enable the use of high-solids. **This will enable future process scenarios including simultaneous saccharification and fermentation (SSF) and Consolidated BioProcessing (CBP).**
- 5 publications (published or submitted), 5 Presentations, 3 records of invention, 1 patent application.



Progressing Cavity Pump



Rotating Ceramic Disc (RCD)



Membrane Contactors

Outline of Progress and Outcomes

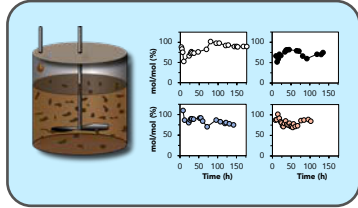

Butyrate production at the bench scale

- Bacterial selection based on product specificity
- Enhancing glucose and xylose co-utilization
- Performance of *C. tyrobutyricum* at pH 5 in ISPR systems
- HED-ISPR System Overview
- Towards increasing fermentation length and productivity



Metabolic and evolutionary engineering to increase strain performance

- *C. tyrobutyricum* metabolic engineering
- *C. tyrobutyricum* strain improvement
- Alternative hosts for carboxylic acids production

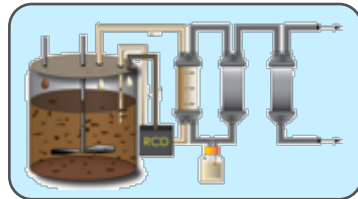

Towards scaling up butyrate production

- HED-ISPR dramatically improves economics and reduces environmental impact
- Scaling up using mobile pilot plant skids
- FY21 design & build 100L HED-ISPR system

Enhancing glucose and xylose co-utilization

Development of 'induced' seeds with xylose consuming *C. tyrobutyricum*

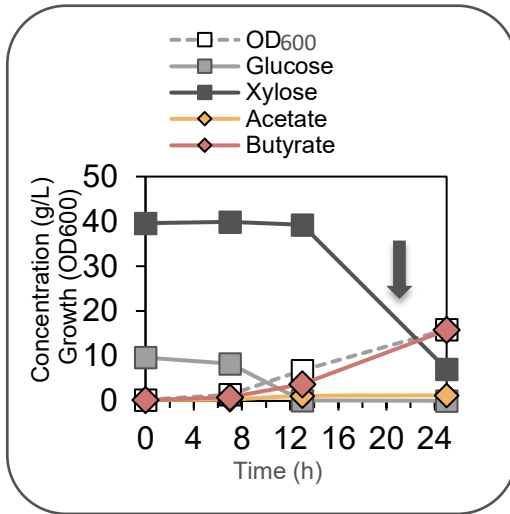

Xylose utilization in mixed sugar fermentations

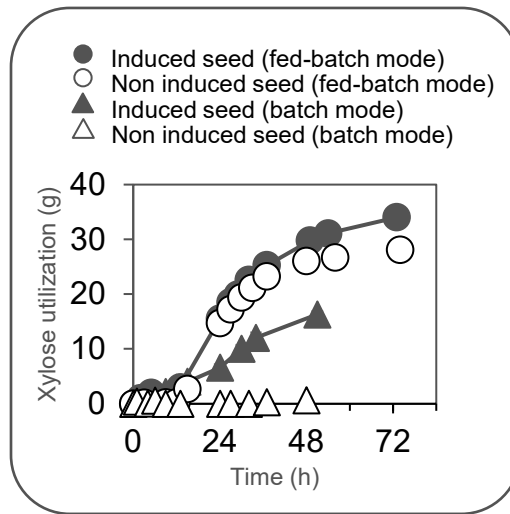

Bioprocess development to enhance titers and productivities from corn stover hydrolysate

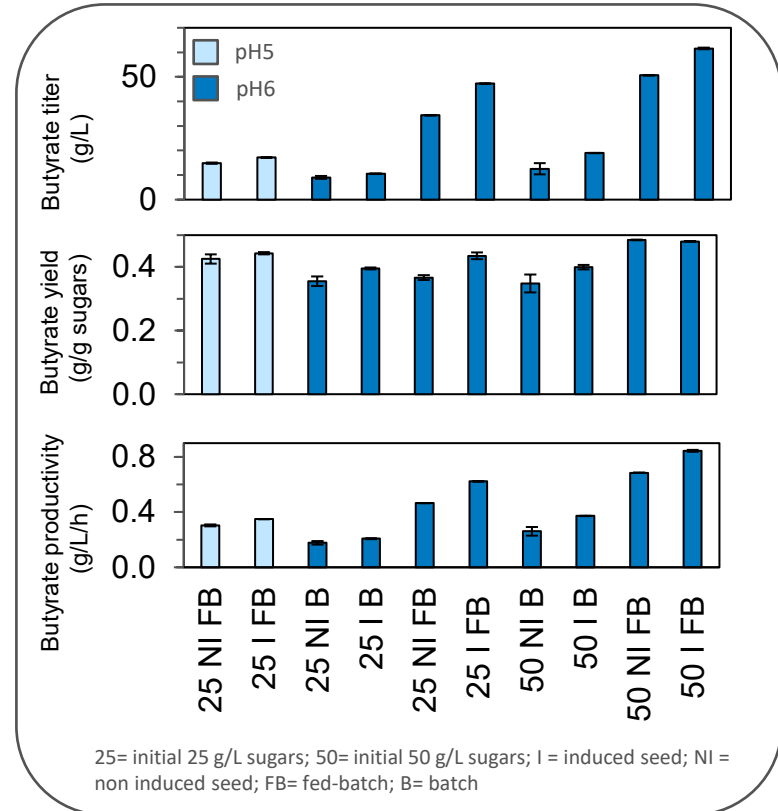

C. tyrobutyricum can efficiently co-utilize sugars in fed-batch mode

- The utilization of 'induced' seeds enhances xylose utilization in batch mode fermentations
- Butyrate titers of 62 g/L, yields of 0.48 g/g and productivities of 0.84 g/L/h are achieved at pH 6 in fed-batch mode.

Performance of *C. tyrobutyricum* at pH 5 in ISPR systems

Liquid-liquid extraction (LLE)-ISPR

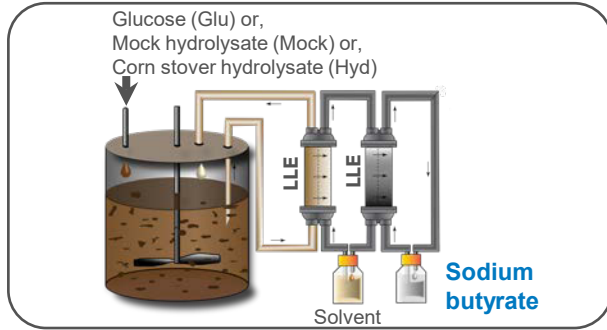

Hybrid extraction distillation (HED)-ISPR

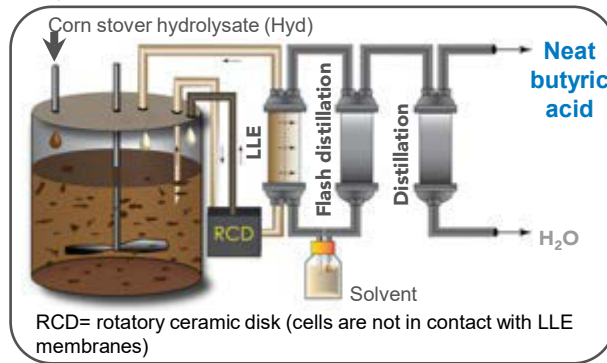

Bacterial performance on different substrates in LLE- and HED- ISPR systems

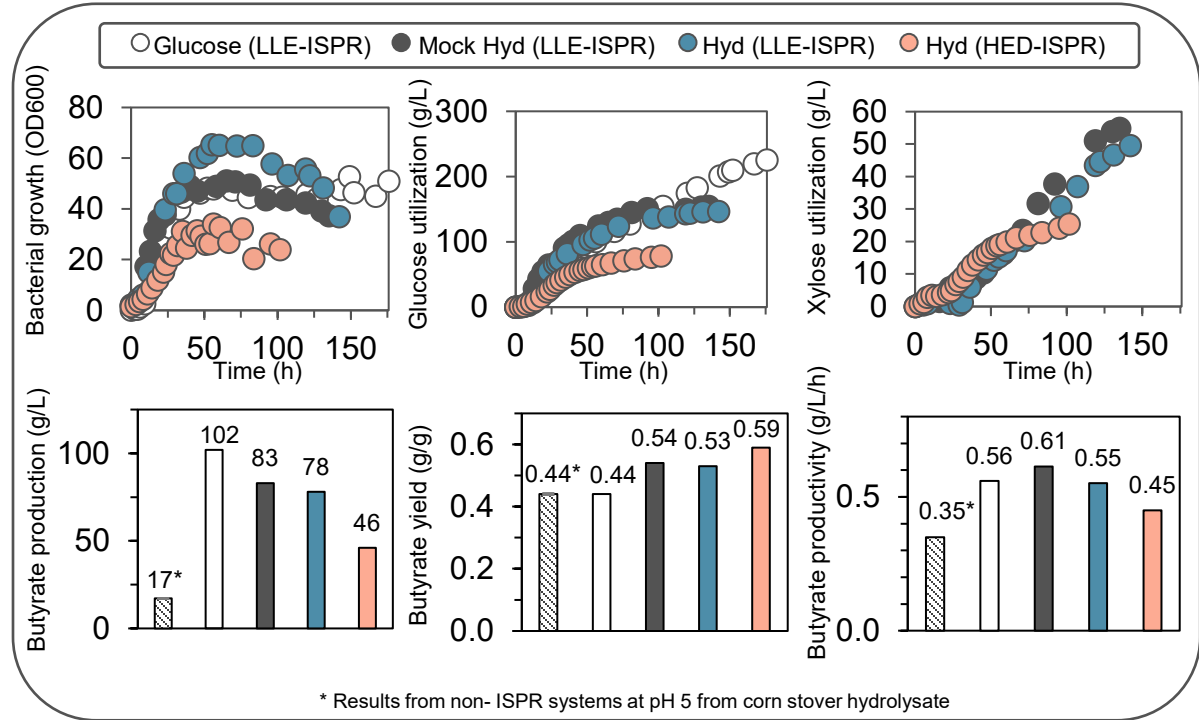

ISPR systems promote near homo-butyrates fermentations in *C. tyrobutyricum*

- LLE-ISPR systems allowed the production of up to 78 g/L of butyrate from corn stover hydrolysate
- The solvent utilized in the HED-ISPR process is moderately toxic for the bacterium (which results in a lower titer and productivity). We are currently evaluating solvents with lower toxicity but similar properties

HED-ISPR System Overview

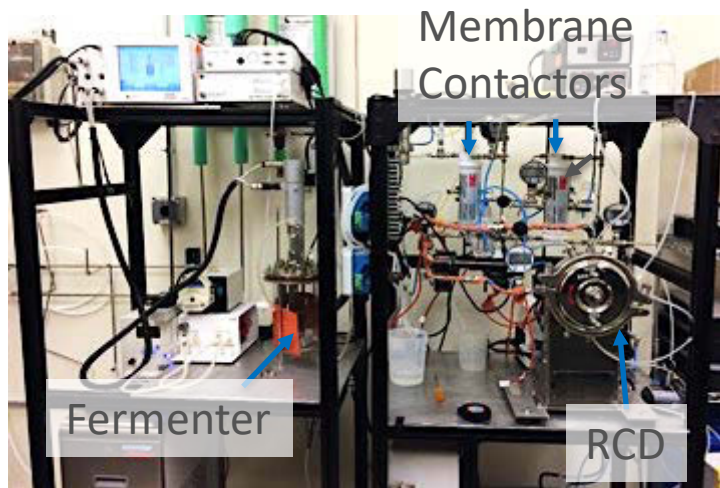

Bench Scale Pertractive Fermentation Unit

- 3 L bioreactor
- Hollow fiber membrane contactors for LLE
- Rotating ceramic disk membrane for cell removal before LLE
- Temperature, Pressure and Flow control
- Continuous operation demonstrated for more than 300 hours
- 100s of grams butyric acid produced per run



Custom flash recovery system

- Built to remove butyric acid from extractant.
- Spinning band distillation used for polishing step
- Eliminates need for NaOH used to back-extract in traditional LLE approaches.

Bench Scale HED-ISPR enables process optimization and strain evaluation

- Continuous operation demonstrated for greater than 300 hours
- 100s of grams butyric acid at >98% purity produced per run.

Towards increasing fermentation length and productivity

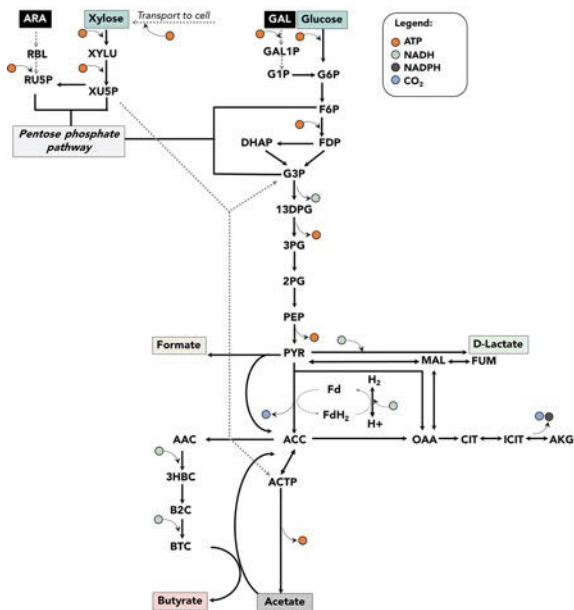

Butyrate
metabolic yield

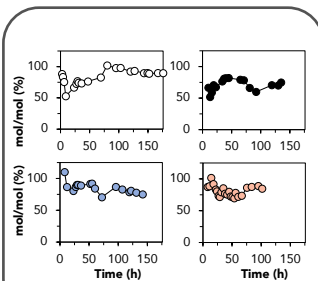

Acetate
metabolic yield

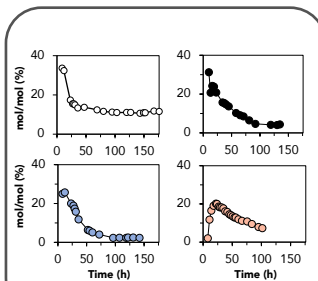

Formate
metabolic yield

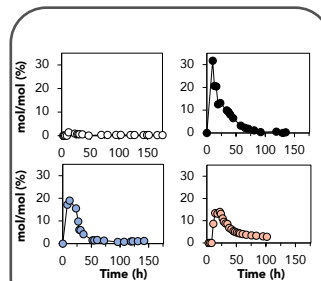

Lactate
metabolic yield

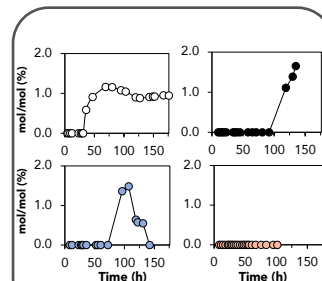

○ Glucose (LLE-ISPR)

● Mock hydrolysate (LLE-ISPR)

● Hydrolysate (LLE-ISPR)

● Hydrolysate (HED-ISPR)

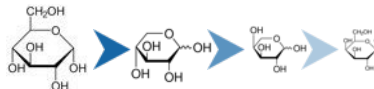
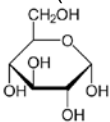

The presence of xylose in ISPR systems shortens fermentation length compared to glucose-only containing fermentations

- Acetate, formate, lactate metabolic differ between glucose- and mixed sugars- containing media
- We are currently conducting proteomics (collaboration with Dr. Robert Hettich, Oak Ridge National Laboratory) and redox analyses to understand the effect of xylose on *C. tyrobutyricum* metabolism compared to glucose to ultimately rationally engineer *C. tyrobutyricum* and prolong the fermentations.



C. tyrobutyricum Metabolic Engineering

Tool Development: In collaboration with Adam Guss at Oak Ridge National Laboratory and the Agile BioFoundry (ABF), we successfully generated conjugative strain with *C. tyrobutyricum* methyltransferases to improve the DNA transformation efficiency.

CA434 Conjugative Strain

Conjugative Strain + Methyltransferases

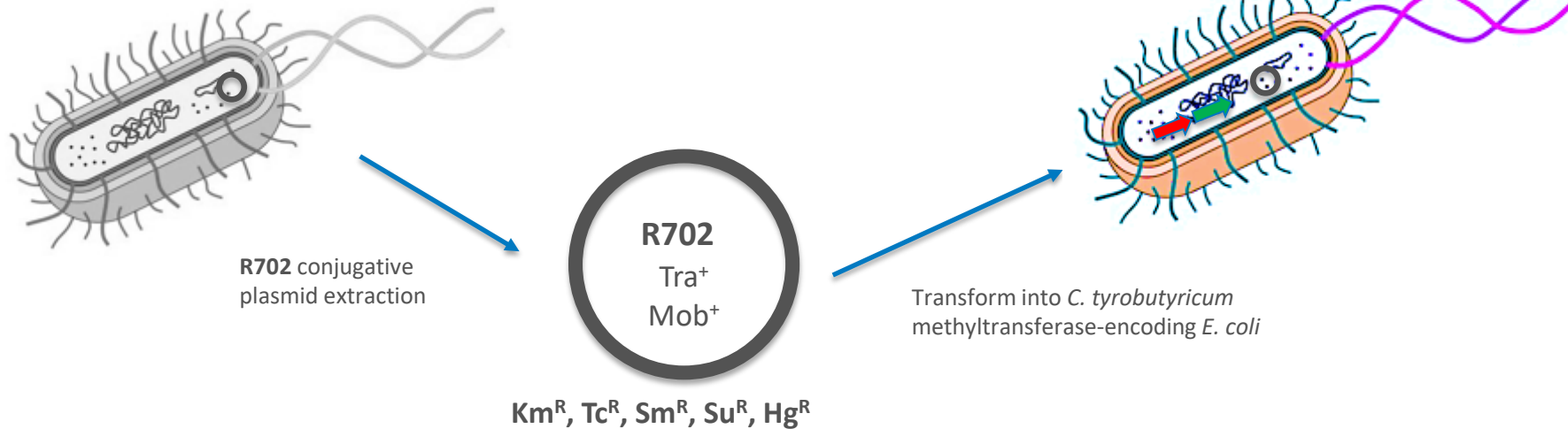

Transformation efficiency has been improved ~1,000-fold in *C. tyrobutyricum*

C. tyrobutyricum Strain Improvement

Strain Engineering to Improve C₅ Utilization

C. tyrobutyricum strain expressing heterologous xylose pathways enables co-utilization of glucose and xylose.

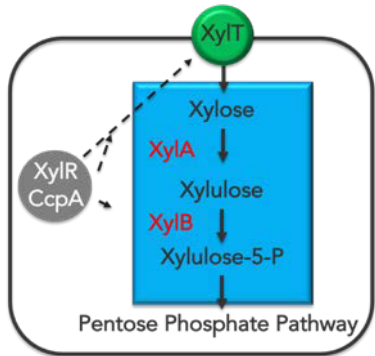

Xylose and glucose are co-consumed in our engineered strain

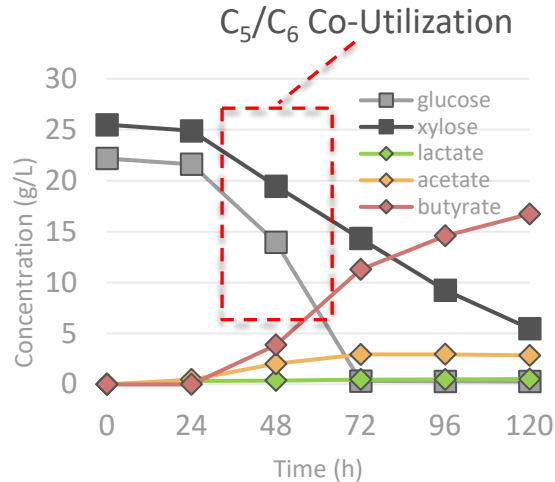

Adaptive laboratory evolution to improve growth at lower pH

AIM: Enhancing butyrate productivity and extraction efficiency by serial batch transfers at controlled **pH 4.8** under anaerobic conditions.



Evolution has been running for over 1,000 hours with dramatic increase in sugar utilization rates.

Evolved culture has improved performance in low pH conditions, which enhances HED-ISPR pertraction.

HED-ISPR Dramatically Improves Economics and Reduces Environmental Impact

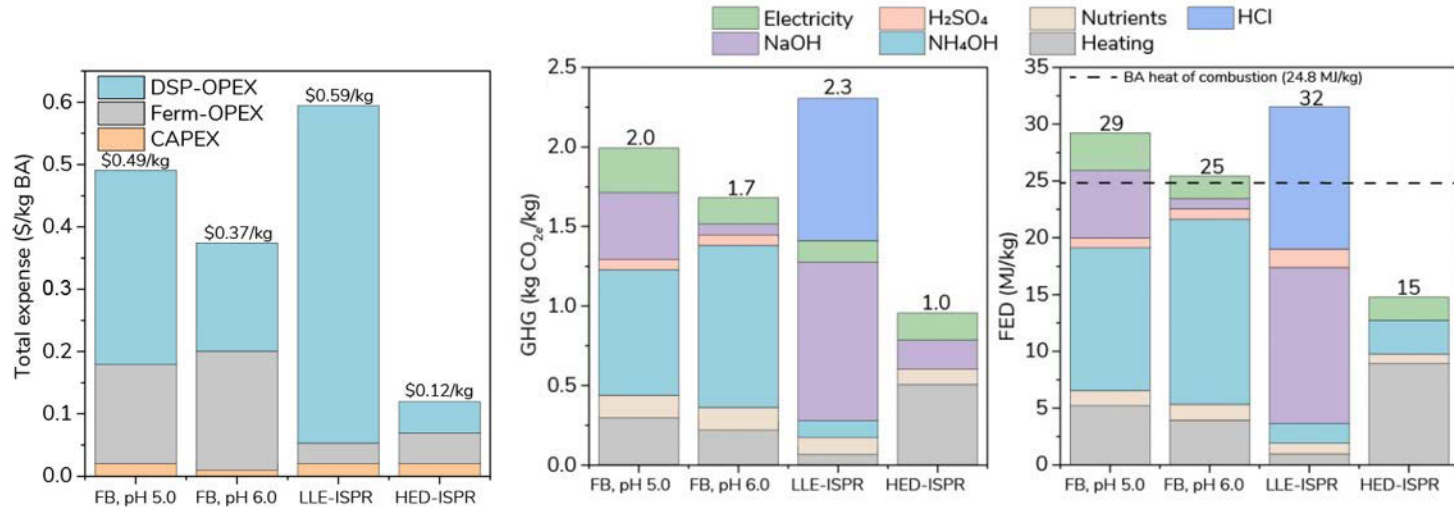

- The higher cost of LLE-ISPR results from the chemical consumption of sodium hydroxide in back extraction
- \$0.12/kg represents 14% of the total expense.
- **Total projected expense is \$0.84/kg. Current biobased butyric acid market price is ~\$1.80/kg.**
- Clear targets to reduce projected expenses further:
 - Reduced-toxicity extractant
 - Improved fermentation longevity
 - Arabinose utilization
 - Improved productivity at pH 5.0

Scaling Up Using Mobile Pilot Plant Skids

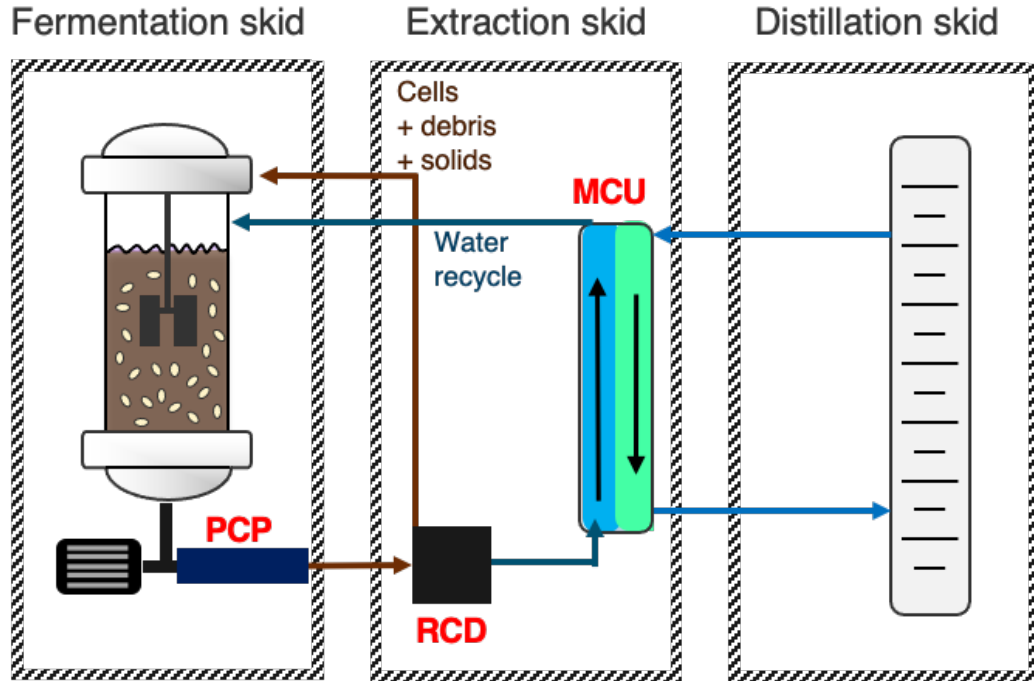

Neat
VFAs



- 3-10 kg of neat butyric acid per week run
- Automated control system
- Future catalysis skids are tentatively planned

FY21 Design & Build 100L HED-ISPR System

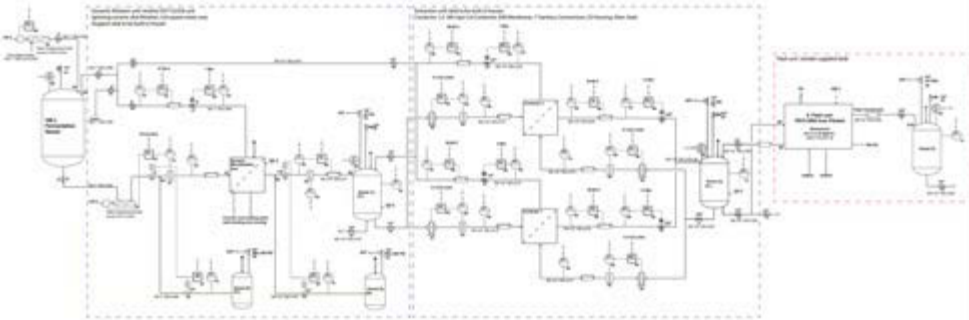

Pilot-Scale P&ID

- Turnkey flash distillation
- 0.8 m² RCD unit from Andritz
- Scaled up membrane contactors
- Progressing cavity pumps to circulate broth and hydrolysate
- **System will bring versatile capability for ISPR with high solids for products beyond ethanol that are non-volatile:**
 - **Waste to energy projects**
 - **CBP & SSF processes**
 - **Capable of solids contents > 13 wt.%**



160L Fermenter



Pilot-Scale RCD



Flash Distillation



Progressing Cavity Pumps



Membrane Contactors

Neat butyric acid will be delivered to downstream catalytic upgrading efforts in CUBI and ChemCatBio and other BETO efforts to demonstrate end-to-end platform for fuels including diesel and Sustainable Aviation Fuel

Near Term Directions

- Build, commission and optimize pilot-scale reactor to enable 10's of kgs neat biobutyric acid. Deliver to downstream partners.
- Tune fermentations and ISPR to maximize both titer and productivity metrics, optimize product recovery through organic extraction and distillation.
- Improve strain performance to maximize carbon utilization and flux towards butyric acid at $\text{pH} \leq 5.0$

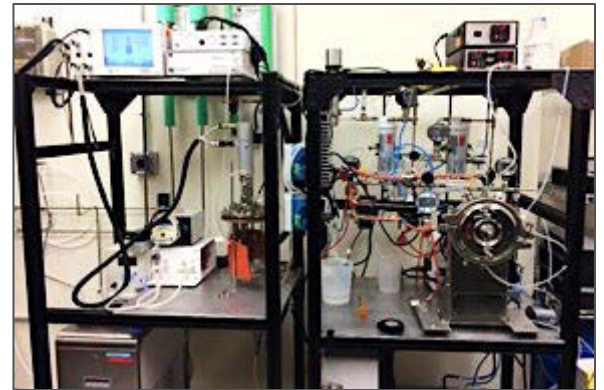



ACKNOWLEDGEMENTS

• **BETO:** Jay Fitzgerald & Ian Rowe

- Davinia Salvachúa
- Eric Karp
- Violeta Sánchez i Nogué
- Michael Guarnieri

- Anahita Bharadwaj
- Yat Chen Chou
- Carlos del Cerro
- Nicholas Cleveland
- Ryan Davis
- Mary Ann Franden
- Sfehan Haugen
- Colin Kneucker
- Megan Krysiak
- Kavita Ramnath
- Michelle Reed
- Lauren Riley
- Patrick Saboe
- Christine Singer
- Sean Woodworth

Collaborators

- Yannick Bomble, Center for Bioenergy Innovation
- Paola Branduardi, University of Milano
- Adam Guss, Oak Ridge National Laboratory
- Neal Hengge, Center for Bioenergy Innovation
- Bob Hettich, Oak Ridge National Lab
- Andrew Sutton, Los Alamos National Lab
- Derek Vardon, ChemCatBio
- Separations Consortium
- Biochemical Analysis Platform
- Arrested Anaerobic Digestion
- Feedstock Conversion Interface Consortium
- Agile Biofoundry

NREL/PR-2800-79462

Thank you!

This work was authored by the National Renewable Energy Laboratory, operated by Alliance for Sustainable Energy, LLC, for the U.S. Department of Energy (DOE) under Contract No. DE-AC36-08GO28308. Funding provided by the U.S. Department of Energy Office of Energy Efficiency and Renewable Energy Bioenergy Technologies Office. The views expressed in the article do not necessarily represent the views of the DOE or the U.S. Government. The U.S. Government retains and the publisher, by accepting the article for publication, acknowledges that the U.S. Government retains a nonexclusive, paid-up, irrevocable, worldwide license to publish or reproduce the published form of this work, or allow others to do so, for U.S. Government purposes.

Funding:



Additional Slides

Alternative hosts for carboxylic acids production

Non-conventional yeasts

Pichia kudriavzevii and *Zygosaccharomyces parvii* were considered as potential hosts due to their tolerance to low pH

Adaptation to butyric acid at low pH

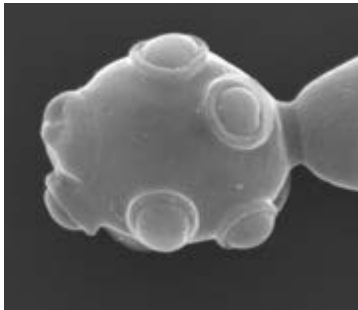

OMICS to elucidate adaptive cellular machineries at low pH

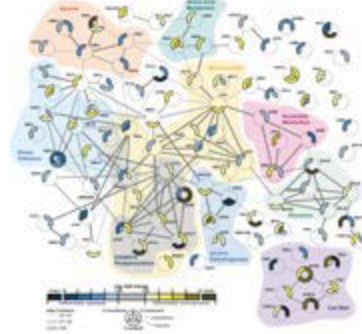

- Challenging genetic engineering
- High toxicity to butyric acid

C. thermobutyricum

Glucose and xylose metabolism

Produces butyrate as the major fermentation product

Strict anaerobic

Moderately thermophilic

Increased production rates and improved mass transfer

Reduced susceptibility to contamination

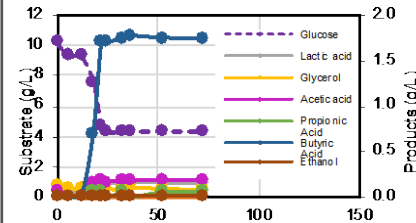

Evaluation of potential alternative hosts to advance carboxylic acids platform

- Early results and FY19 Peer Review comments lead to pivoting away from yeast platform to clostridial platform
- *C. thermobutyricum* is being evaluated and compared to *C. tyrobutyricum* SOT data
- If successful *C. thermobutyricum* could also be used in co-cultures for a solids to fuels pathway using a consolidated bioprocess approach

Responses to Previous Reviewers' Comments

“The route involving [Acid-tolerant] yeast is far less developed and does not integrate well with the bacterial work. It is also not clear whether these strains can produce butyric acid at high rates and titers. This work is still in the discovery phase. As such, this part of the project is not very compelling. Focusing on one system would allow for more rapid progress.” -While the promise of a low-pH, acidotolerant species was promising in our initial phylogenetic survey, we agreed with the reviewers here and have moved on from this course of research. Our top yeast strains were indeed tolerant to low pH (2.0), and to high concentrations of butyric acid (0.4 M) at neutral pH, the combination of high acid concentrations at low pH has thus far proven too lethal to present a viable path forward *in the near term*. Accordingly, we have moved the entirety of our resources over to the *Clostridium* platform focusing on bioprocess development, separations, scale up and strain improvement.

Responses to Previous Reviewers' Comments

“Developing a process involving continuous distillation will be an important step for establishing feasibility and connecting with TEA.”-We agree with this sentiment entirely and have made this a large focus of the project over the last two years. We strengthened our collaboration with the Separations Consortium and have onboarded staff to make separations and scale up an integral component of the BUS project. Our preliminary runs with the fully integrated bench system models dramatic (53%) cost savings over fed batch processes, and more traditional Liquid-Liquid Extraction coupled with back extraction.

Presentations

- **2019.** Salvachua. Biological production of carboxylic acids from biomass sugars and further upgrading to fuels. 41st Symposium on Biotechnology for Fuels and Chemicals, Seattle, WA.
- **2020.** Sànchez i Nogué. Non-conventional yeasts as novel hosts for biotechnological applications. 42nd Symposium on Biomaterials, Fuels and Chemicals. New Orleans, LA (COVID-related cancellation)
- **2020.** del Cerro. Evolutionary engineering studies of non-model yeasts to understand adaptive mechanisms to weak acids at low pH. Rocky Mountain Yeast Meeting.
- **2020.** Ramnath. Comparative Multi-Omics Studies Of Non-Conventional Yeasts To Understand Low pH Tolerance Mechanisms In Hydrolysate Cultivation. Rocky Mountain Yeast Meeting
- **2020.** Kneucker. Evolutionary engineering studies of non-model yeasts to understand adaptive mechanisms to weak acids at low pH. Rocky Mountain Yeast Meeting.

Publications, Patents, Presentations, Awards, and Commercialization

Publications

- Jeffrey G. Linger, Leah R. Ford, Kavita Ramnath, and Michael T. Guarnieri (2020) Development of *Clostridium tyrobutyricum* as a Microbial Cell Factory for the Production of Fuel and Chemical Intermediates From Lignocellulosic Feedstocks. *Front. Energy Res.* 8:183. doi: 10.3389/fenrg.2020.00183
- Davinia Salvachúa, Patrick O. Saboe, Robert S. Nelson, Christine Singer, Ian McNamara, Carlos del Cerro, Yat-Chen Chou, Ali Mohagheghi, Darren Peterson, Stefan Haugen, Nicholas S. Cleveland, Hanna R. Monroe, Michael T. Guarnieri, Eric C. D. Tan, Gregg T. Beckham, Eric M. Karp, Jeffrey G. Linger. Butyric acid production from lignocellulose by Clostridia: metabolic insights, process intensification, and techno-economic analyses. *Submitted*.
- Carlos del Cerro Sánchez, Alida T. Gerritsen, Christine A. Singer, Mary Ann Franden, Kavita Ramnath, Colin Kneucker, Michelle L. Reed, Gregg T. Beckham, Jeffrey G. Linger, and Violeta Sánchez i Nogué. Low pH adaptative cellular machineries in non-conventional yeasts. *Submitted*.
- Nemmaru, Bhargava, Nicholas Ramirez, Cindy J. Farino, John M. Yarbrough, Nicholas Kravchenko, and Shishir PS Chundawat. "Reduced type-A carbohydrate-binding module interactions to cellulose I leads to improved endocellulase activity." *Biotechnology and Bioengineering* (2020).
- Huo, Xiangchen, Nabila A. Huq, Jim Stunkel, Nicholas S. Cleveland, Anne K. Starace, Amy E. Settle, Allyson M. York et al. "Tailoring diesel bioblendstock from integrated catalytic upgrading of carboxylic acids: a "fuel property first" approach." *Green Chemistry* 21, no. 21 (2019): 5813-5827.

US Patent Applications, Records of Invention

- Advanced Anaerobic digestion to carboxylic acids U.S. Patent App. No. 63/020,598
- Mechanisms of Acid Tolerance in Yeast (In preparation, Record of Invention filed, ROI 20-65).
- Performance Enhanced Yeast (ROI 20-10)