



# Design Protection Schemes for 100% Renewable Microgrids

Jing Wang, Ahmed Zamzam, and Kumar Soumitra  
December 5, 2022

# Agenda

**1** Challenges in 100% Renewable Microgrid Protection

**2** Inverter-based Resources (IBRs) Fault Characteristics

**3** Banshee Benchmark Microgrid

**4** Fault Study and Protection Design

**5** Data-driven Protection Design

**6** Key Takeaways

**Part I: Generic Concept**

**Part II: Example  
Microgrid Use Case**

# Part I: Generic Concept

---

# 100% Renewable Microgrids

- Variations in fault current:
  - Grid-connected and islanded mode
  - Distributed energy resource (DER) operation modes, IEEE 1547
  - Weather conditions (e.g., solar irradiance).
- Bidirectional power flow
- Inconsistent phase angle
- Blinding and sympathetic tripping
- Low inertia leading to critical frequency abnormalities in islanded mode
- Limited short-circuit capacity
- Scarcity of low-cost protective devices.

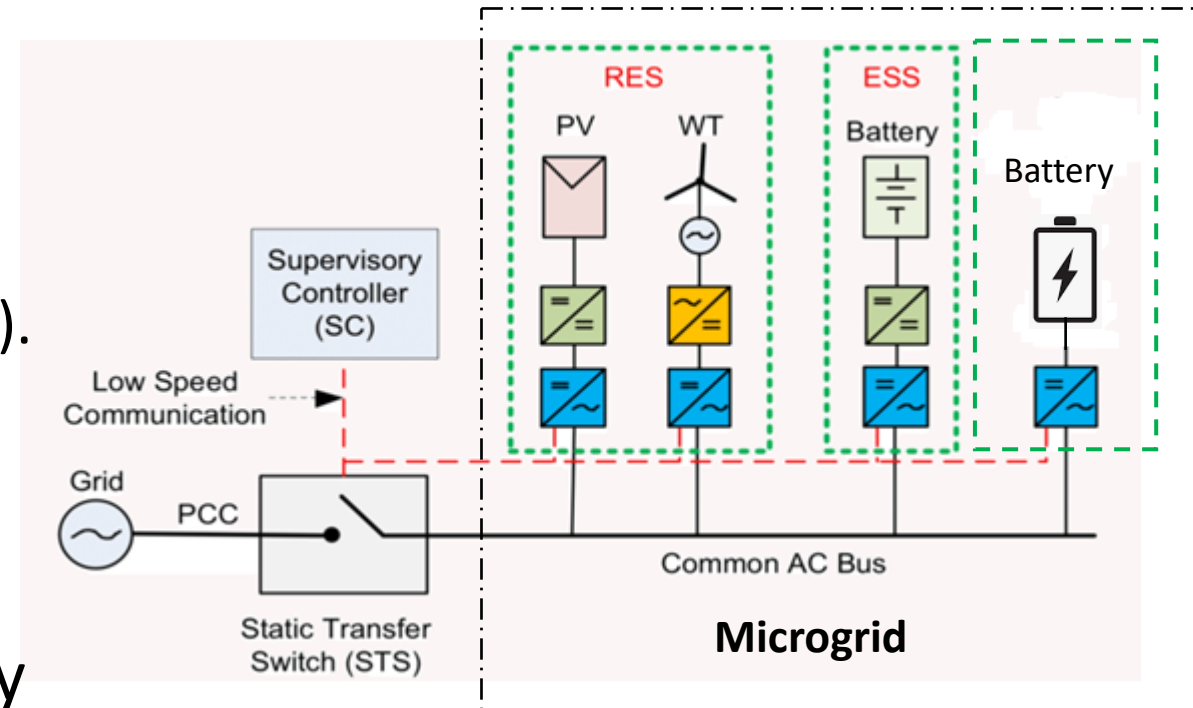

# Inverter-Based Resources

- Inverters do not dynamically behave the same as synchronous/induction machines. They do not have fault currents based on the electromagnetic characteristics that a traditional machine has.
- Fault currents have a much faster decaying envelope because the devices lack the predominantly inductive characteristics that are associated with rotating machines.
- Inverter-based resource (IBR) control loops can have different time constants. This will impact the fault current characteristics of the inverters.
- Inverter behavior is largely software/firmware defined; the filter determines the sub-transient response, and the type of control implementation determines the steady-state response.
- The rule of thumb adopted by industry is to consider the fault current from 1.2 to 1.5 times the rated current.

# Types of Inverter Control

Inverter controls can be grouped into three categories: grid-following (GFL), grid-forming (GFM), and grid-supporting.

- *GFL* inverters are referred to as current control because the current is the physical quantity that is regulated. They need the grid voltage for operation. They are used to inject real and reactive power as per the requirement.
- *GFM* inverters provide functionalities that are traditionally provided by synchronous machines. They can be designed to autonomously establish frequency and control voltage.
- *Grid-supporting* controls can be GFL control (f-P, v-Q, synthetic inertia) and GFM control (P-theta, Q-v).

GFL and GFM IBRs have different fault characteristics.

# Characterize GFL IBR Fault Current Response With 1547 Compliance

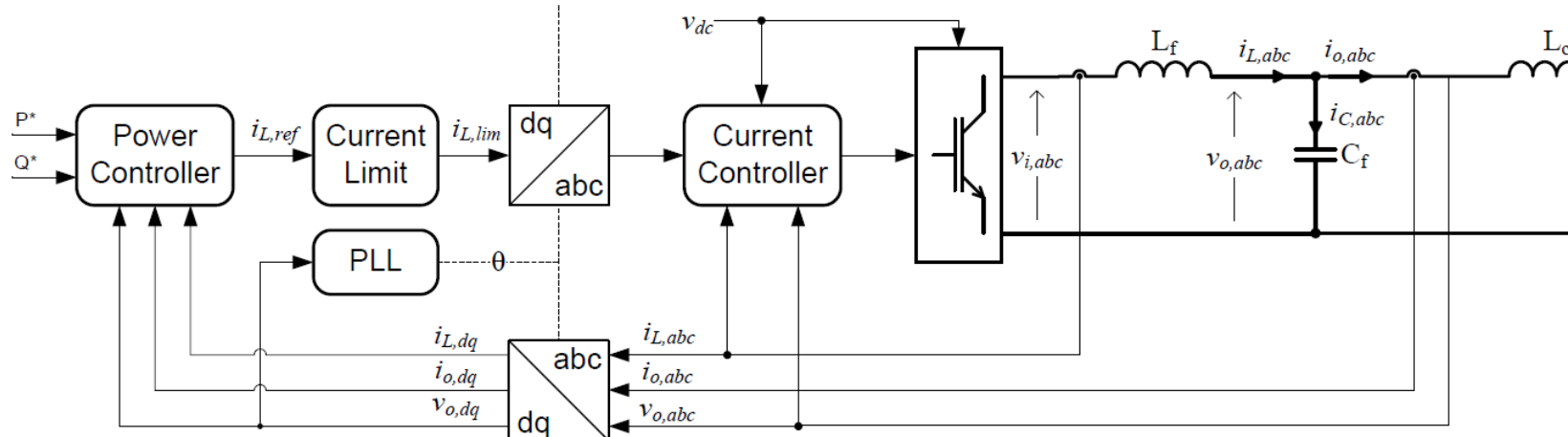

GFL inverter fault response (PQ injection)<sup>1</sup>

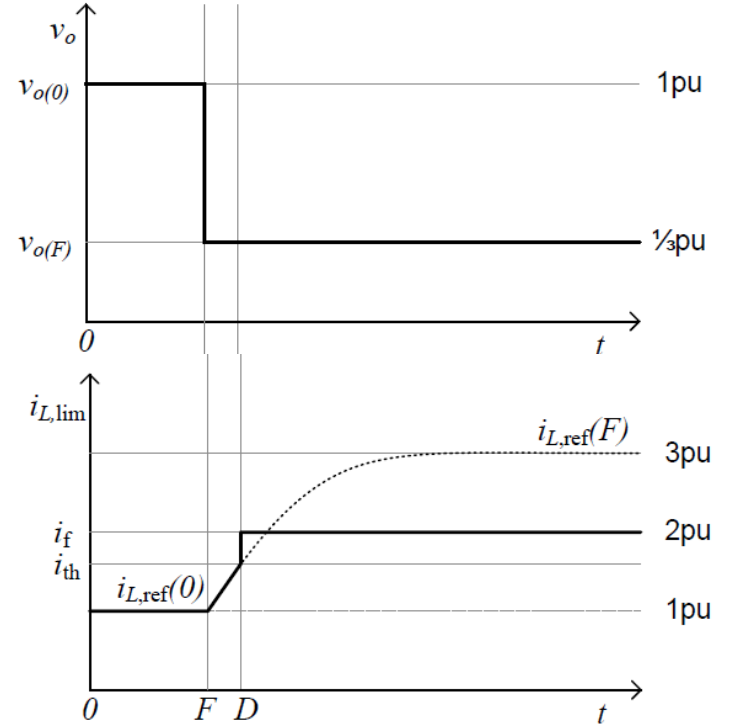

- The fault current of an IBR is a function of the control schemes as well as the physical components of the power electronics.
- It is analytically calculated based on the transient dynamics:
  - Pre-fault, transient, and steady state.

$$\vec{i}_{L,\text{ref}}(t) = \vec{i}_{L,\text{ref}}(0) + \left( \vec{i}_{L,\text{ref}}(F) - \vec{i}_{L,\text{ref}}(0) \right) \cdot (1 - e^{-\omega_c t})$$

$\vec{i}_{L,\text{ref}}(0)$  is determined by the Power Controller (Steady-state voltage).  
 $\omega_c$  is the LPF cutoff frequency.

$$\vec{i}_{L,\text{lim}} = \text{if } \begin{cases} t \leq F & \vec{i}_{L,\text{ref}}(0) \text{ Pre-fault} \\ F < t \leq D & \vec{i}_{L,\text{ref}}(0) + \left( \vec{i}_{L,\text{ref}}(F) - \vec{i}_{L,\text{ref}}(0) \right) \cdot (1 - e^{-\omega_c t}) \text{ Transient} \\ t > D & \vec{i}_f \text{ Steady-state (hit the limiter)} \end{cases}$$

[1] C. Plet and T. Green, "Fault Response of Inverter Interfaced Distributed Generators in Grid-Connected Applications," *Electric Power Systems Research* 106 (2014): 21–28.

# Characterize GFL IBR Fault Current Response With 1547 Compliance

- The fault current of an IBR is a function of the control schemes as well as the physical components of the power electronics.
- The IEEE 1547 trip and low-voltage ride-through (LVRT) settings significantly affect the response of the GFL DERs.

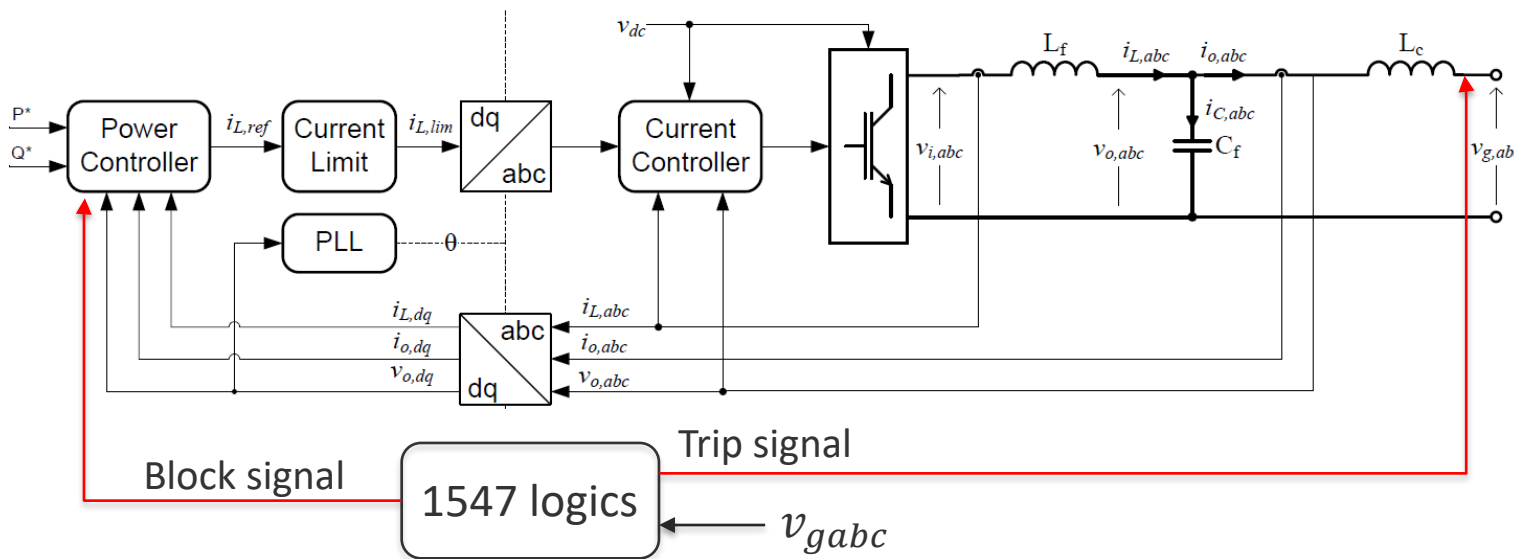

- Momentary cessation: Keep the power injection for the first 5 cycles, and then zero thereafter. The inverter stops gating but remains connected.
- Cease to energize: Stop the power injection and trip.

Trip and LVRT for GFL DERs (Cat. III)

Shall Trip	Voltage (p.u.)	Clearing Time (s)
OV2	1.2	0.16
OV1	1.1	13
UV1	0.88	21
UV2	0.5	2

Voltage (p.u.)	Clearing Time (s)
$V > 1.2$	Cease to energize
$1.1 < V < 1.2$	Momentary cessation
$0.88 < V < 1.1$	Continuous operation
$0.5 < V < 0.88$	Mandatory operation (10 s)
$V < 0.5$	Momentary cessation (2 s)

Fault condition only needs to look at low-voltage areas.



# Characterize GFL IBR Fault Current Response With 1547 Compliance

- Inverter output current reference calculation:

$$i_{L,ref} = I_L \angle \theta_I = \frac{P^* + jQ^*}{V_{gabc} \angle \theta_V}$$

$$I = \begin{cases} I_L, & I_L < I_{max} \text{ and } 0.88 \leq V_{gabc} \leq 1 \\ I_{max}, & I_L > I_{max} \text{ and } 0.88 \leq V_{gabc} \leq 1 \\ I_L, & I_L < I_{max} \text{ and } 0.5 \leq V_{gabc} \leq 0.88 \\ I_{max}, & I_L > I_{max} \text{ and } 0.5 \leq V_{gabc} \leq 0.88 \\ I_L \text{ for 5 cycles and then } 0, & I_L < I_{max} \text{ and } V_{gabc} < 0.5 \\ I_{max} \text{ for 5 cycles and then } 0, & I_L > I_{max} \text{ and } V_{gabc} < 0.5 \end{cases}$$



$I$  is the GFL inverter output current magnitude, and  $I_{max}$  is the maximum allowed current, 1.2 p.u.

- The current limiter dominates the output current response of the GFL inverter.
- Once the maximum current limit is hit, the GFL inverter behaves as a constant current source.
- For very low voltages, the inverter will inject current for the first five cycles and then stops the injection.
- The initial spikes of the inverter current depend on the inverter filters, the fault voltage, and the point-on-wave timing of the fault.
- The DC sources typically do not heavily influence the fault response.

# Fault Response of GFM Inverter

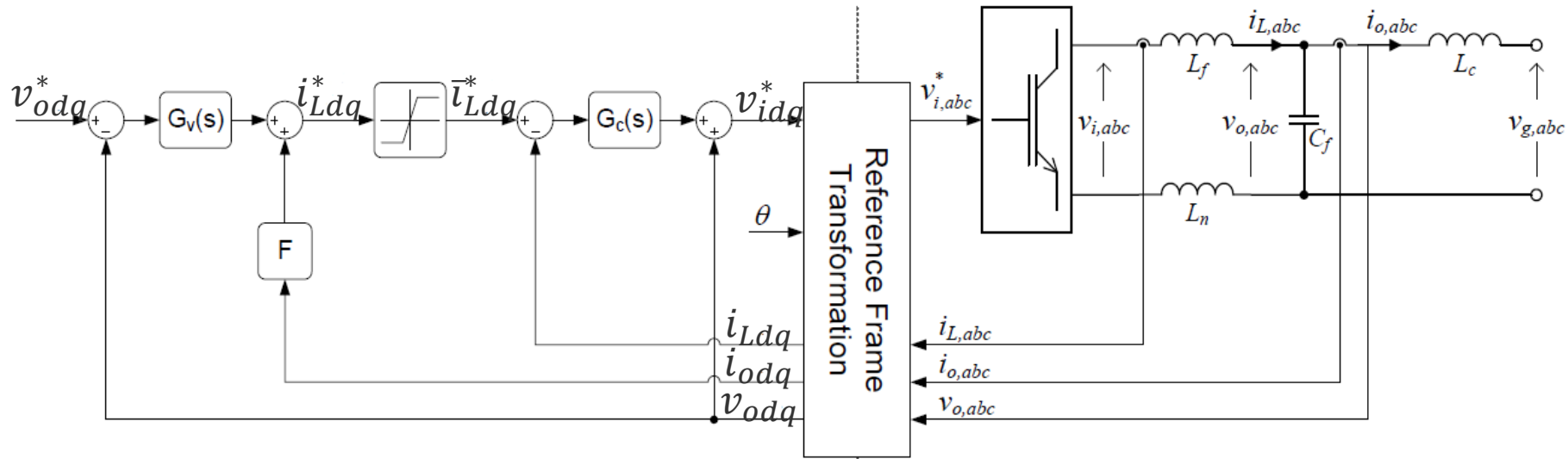

- The fault response depends on the inverter hardware configuration, the inverter control strategy, the current limiter methods, and the reference frame in which the controller and current limiting are implemented.
- **The fault current will be larger than that supplied by GFL controls (especially negative-sequence current).**
- This type of control will have an intrinsically faster response to faults (i.e., current output increase) than GFL because they do not use a faster inner current control loop and/or the current is not directly controlled.

# Fault Response of GFM Inverter Characterization—Symmetrical Fault

ABC and ABCG faults with only positive-sequence component

- Fault response/characteristics of GFM inverter:
  - Balanced output voltage and current
  - Inverter voltage control cannot track the references due to the reduced terminal voltages:
    - Might or might not saturate the inner current loop, depending on the severity of the fault
    - The terminal voltage experiences a step change with transients.

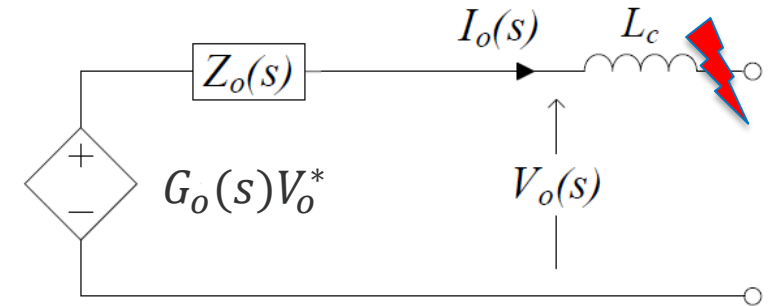

$$V_o(t) = V_o(0) + (V_o(F) - V_o(0))(1 - e^{-\frac{t}{\tau}})$$

$$= \underbrace{V_o(F)}_{\text{Steady state}} + \underbrace{(V_o(0) - V_o(F))e^{-\frac{t}{\tau}}}_{\text{Transient}}$$

$V_o(F)$  is the steady-state voltage, (0) is the pre-fault voltage, and  $\tau$  is the time constant of the voltage control.

$$0 < V_o(F) < V_o(0)$$

- The output current experiences a step change as well.

$$I_o(t) = I_o(0) + (I_o(F) - I_o(0))(1 - e^{-\frac{t}{\tau_1}})$$

$$= \underbrace{I_o(F)}_{\text{Steady state}} + \underbrace{(I_o(0) - I_o(F))e^{-\frac{t}{\tau_1}}}_{\text{Transient}}$$

$I_o(F)$  is the steady-state current,  $I_o(0)$  is the pre-fault current, and  $\tau_1$  is the time constant of the voltage control (if the current limit is hit,  $\tau_1$  is very small, and the output current has fewer transients).

$$I_o(0) < I_o(F) \leq I_{omax}$$

$I_{omax}$  is usually 1.5 p.u.

# Fault Response of GFM Inverter Characterization—Asymmetrical Fault

AG, BG, CG, AB, BC, CA, ABG,  
BCG, and CGA faults

- Fault response/characteristics of GFM inverter:
  - Usually include positive-, negative-, and zero-sequence components
  - Negative-sequence components appear as double harmonics in  $dq$  control.
  - The PI controller will not be able to regulate the resulting double harmonic sinusoidal error to zero.

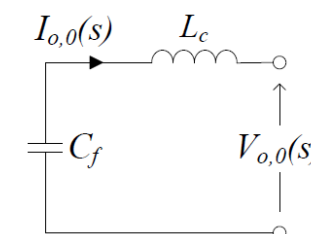
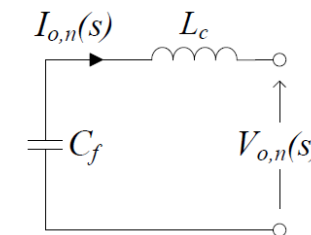
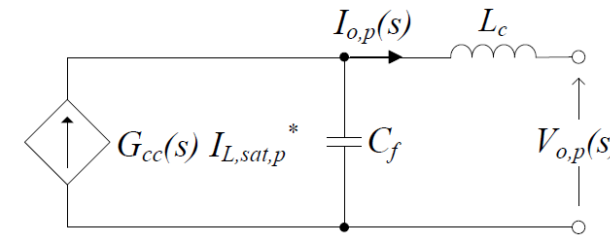
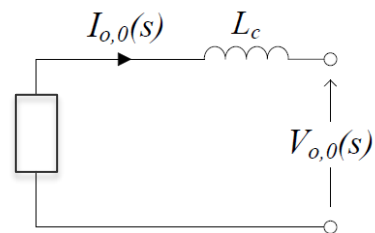
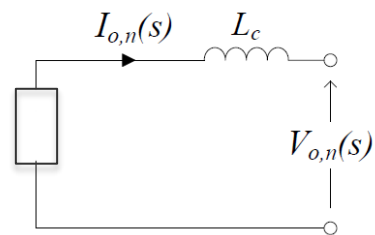
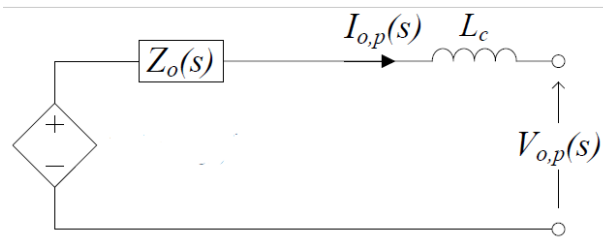

# Part II: Example Microgrid Use Case

---

# Banshee Benchmark Microgrid

- 100% renewables microgrid based on the Banshee microgrid (commercial/industrial):
  - Feeder 2 with two circuits
  - Two GFM battery inverters:
    - GFM control in both grid-connected and islanded mode.
  - Three GFL photovoltaic (PV) inverters:
    - Three operation modes.
  - Constant impedance loads (4.7 MW):
    - Balance and unbalanced loads.
  - Circuit breaker: 5 cycles of mechanical delay
  - Point of common coupling (PCC) relay: grid-connected and islanded mode.

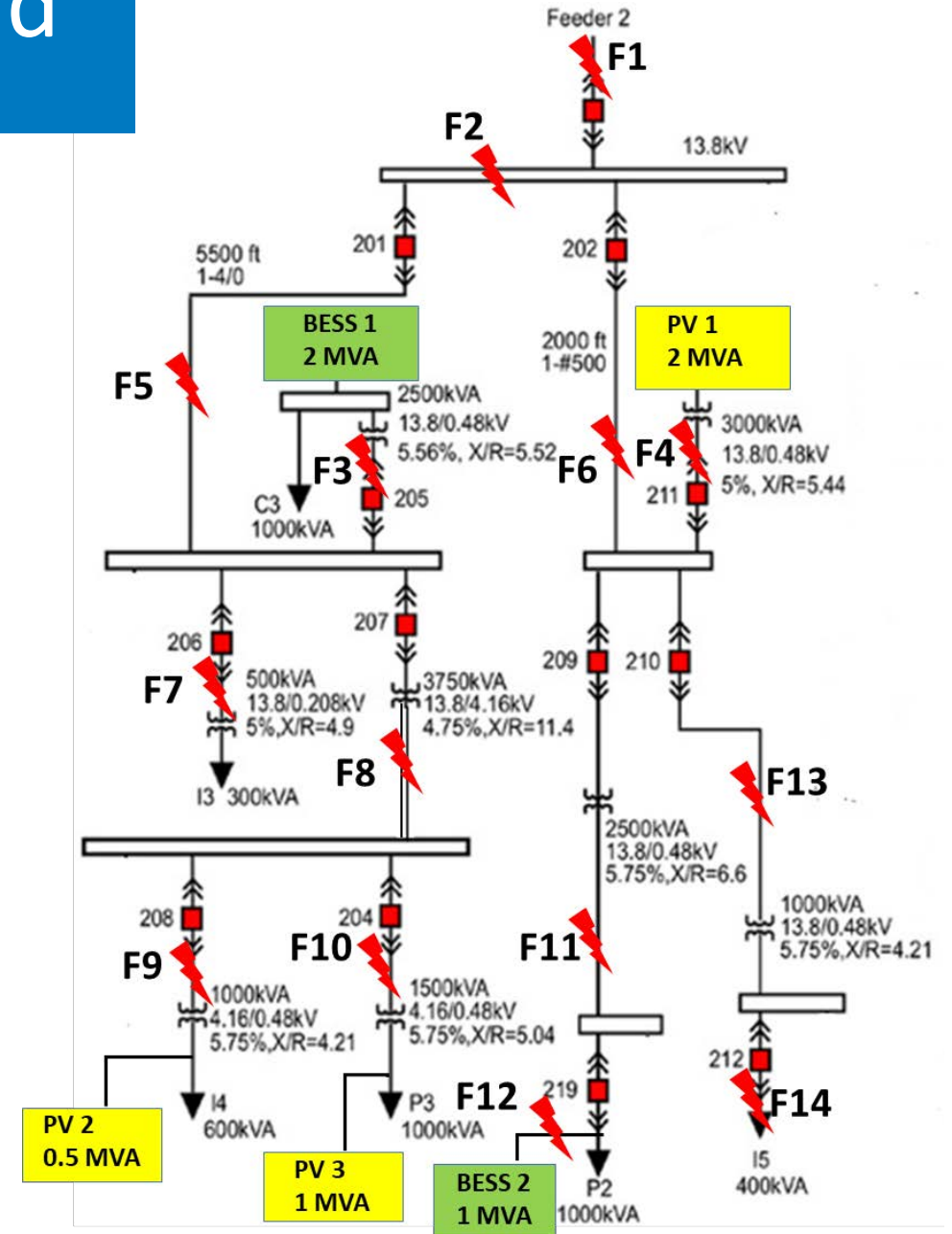

# Banshee Benchmark Microgrid

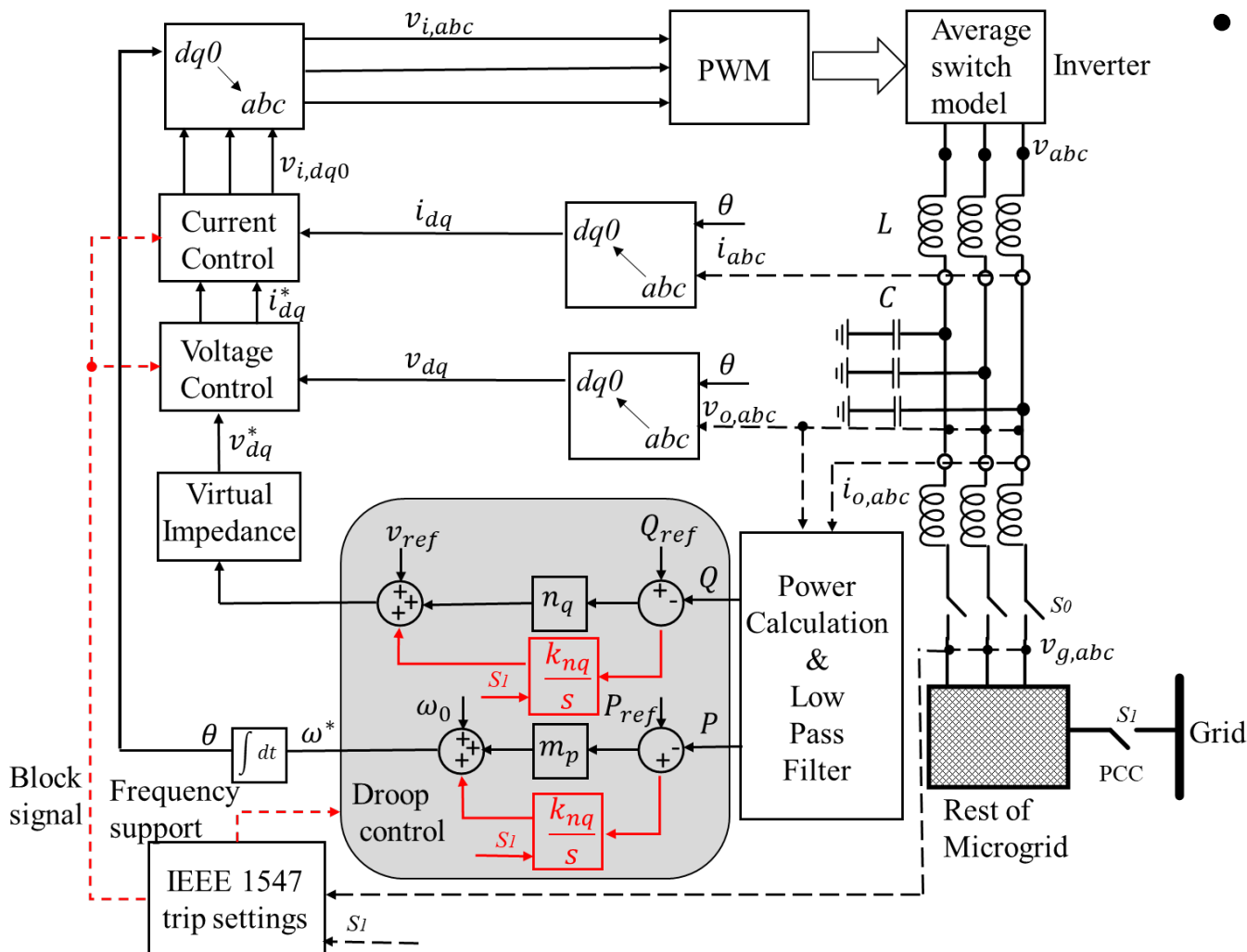

- GFM inverter control:
  - Power tracking for grid-connected mode (integrator in droop control enabled)
  - VF power sharing control for islanded mode (integrator in droop control disabled)
  - IEEE 1547 compliant in grid-connected mode
  - Inverter control layer: virtual impedance control, voltage control, and current control
  - Average switching model.

# Banshee Benchmark Microgrid

- GFL inverter control:
  - Fixed power factor, PQ dispatch, and volt-volt ampere reactive (VAR) control with VAR priority
  - No droop control
  - A phase-locked-loop (PLL) for synchronization
  - IEEE 1547 compliant
  - Average switching model.

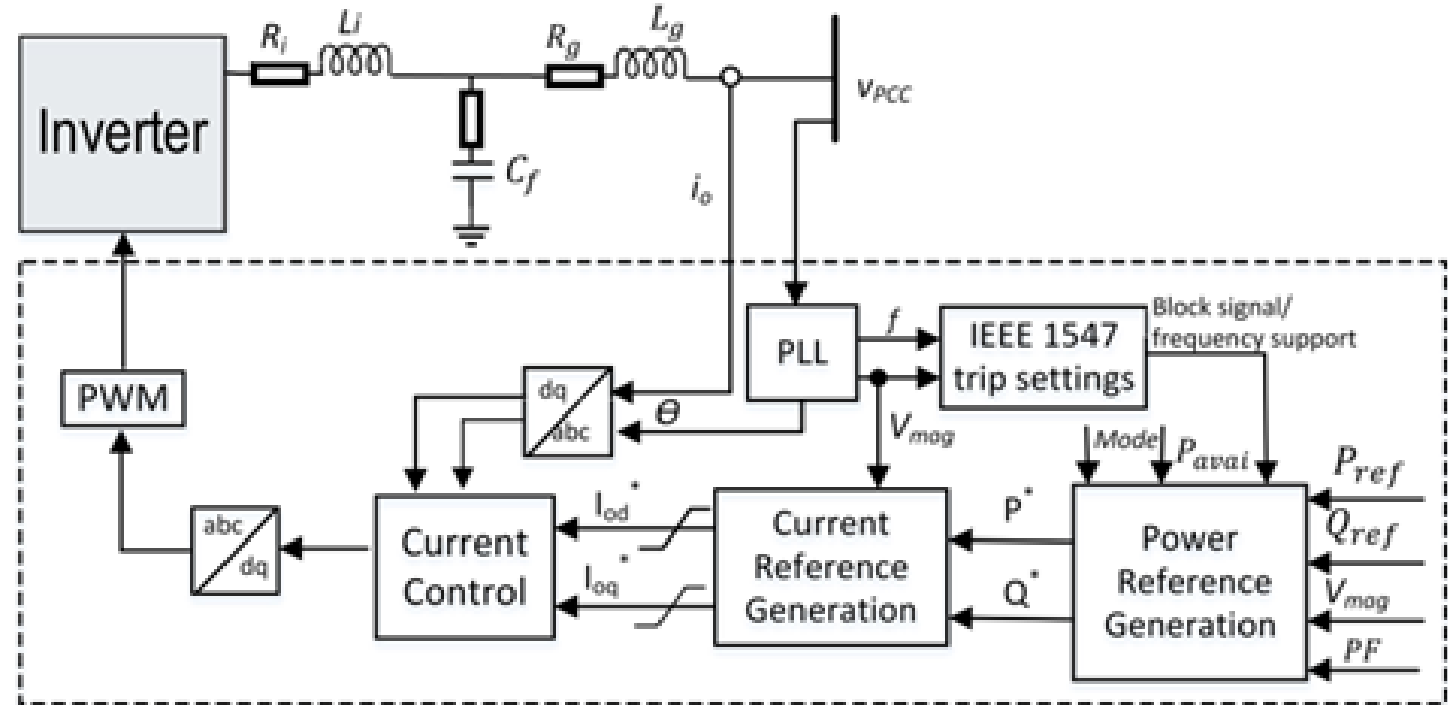



# Challenges With 100% Renewable Microgrid

- In islanded operation, the sources of the fault current contribution are the battery energy storage systems (BESS) and PV. Because the current output is limited to 1.2 times the rated current for PV and 1.5 times the rated current for BESS, the fault current is very low in islanded operation of a microgrid.
- It is observed that due to varying PV output, the various relays across the microgrid see different normal operating currents. Due to the limited fault current contribution from DERs, it is possible that the fault current magnitude in one PV output case is less than the normal operating current magnitude in another PV output case. This implies that the threshold-based overcurrent protection is not sufficient for protection design.
- Due to the limited fault current and short lines across the microgrid, the voltage profile seen by relays across the microgrid for a particular fault is nearly the same; therefore, using voltage-based protection schemes in differentiating faults seems challenging.
- Due to unclear levels of negative-sequence fault current injection from DERs, depending solely on negative sequence-based protection design could lead to undesirable results. Positive-sequence-based logic is added to detect unbalanced faults.

# Traditional Fault Study

- Analyzed the response of IBRs to faults and their contribution to fault currents because they are the main source of fault currents in islanded operation.
- Performed fault study for low-impedance faults and analyzed the protection challenges associated with 100% IBRs.
- Design logics for relays based on the learnings of the fault study.
- Implementation of the overall protection design for the microgrid considering coordination as well.
- Testing and validating protection design. Relay logic modified as required to work under all operating conditions (solar and load profiles).

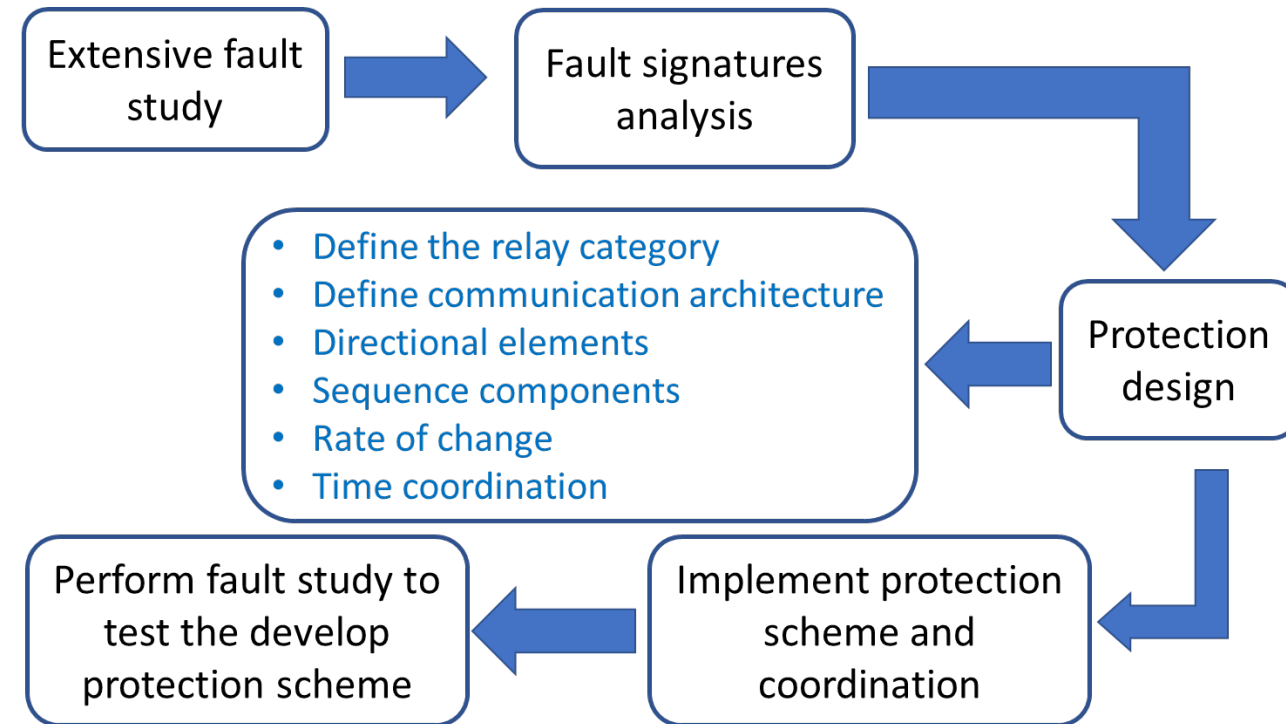

# Fault Study

- Automatic simulation:

- Run hundreds of simulation scenarios.
- Representative solar irradiance and load profiles (8 days from a yearly profiles)
- Follow the predefined test matrix.

- Fault signature extracted:

- Instantaneous voltage and current
- Voltage and current root mean square (RMS)
- Voltage and current sequence components (positive, negative, and zero)
- Rate of change of current sequence components (positive and negative)
- Rate of change of frequency,

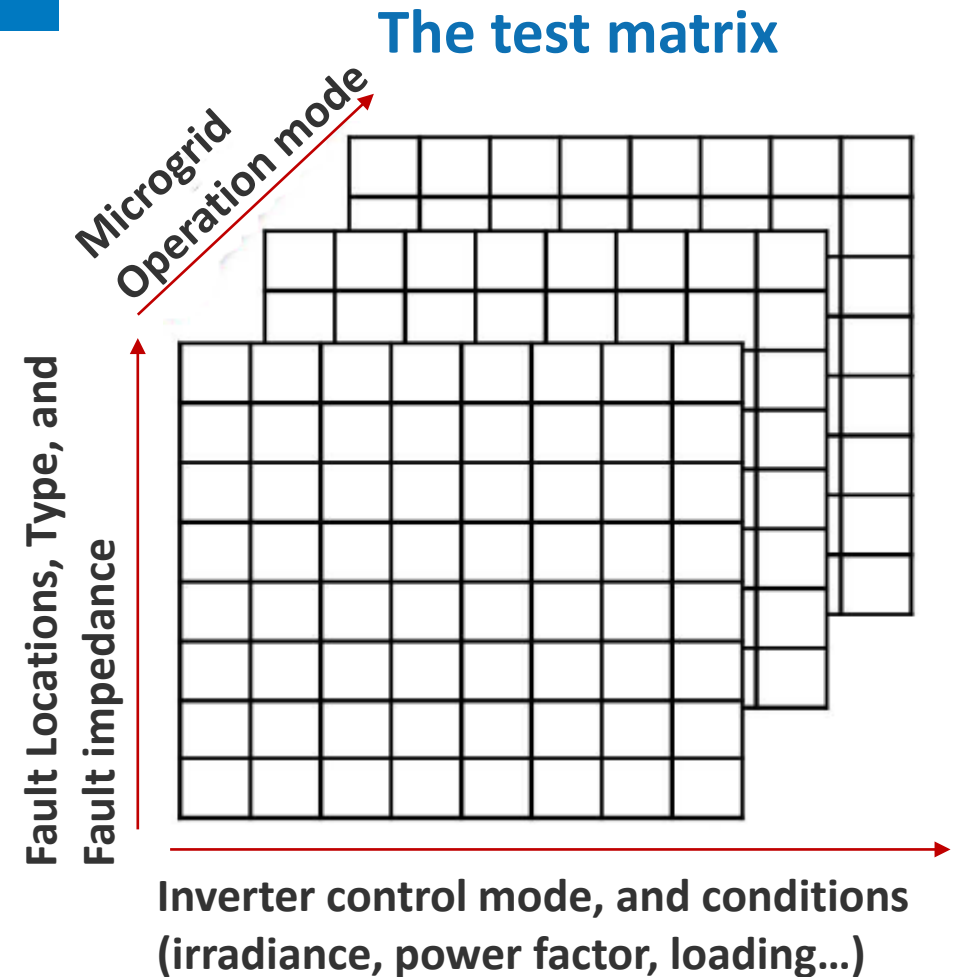

# Protection Design

- The protection design for the microgrid is **adaptive** and **communication-based**. Adaptiveness is necessary due to different current levels in grid-connected/islanded operation and under PV profiles.
- The relay logic is divided into two blocks: the **fault detection block** and the **tripping block**.
  - The fault detection logic of a relay detects the occurrence of a fault by receiving the measured parameters.
  - Once a fault is detected by a relay, the fault signal goes to the tripping logic block, where the trip signal is generated. The trip signal is generated only if the relay does not receive a blocking signal from any adjacent relay.
- There are **14 defined faults** for which the protection logic should work. Each relay is primarily designed to detect and isolate a particular fault for which it is solely responsible. (Relays can send inter-transfer signals to other relays to isolate a faulted section.)

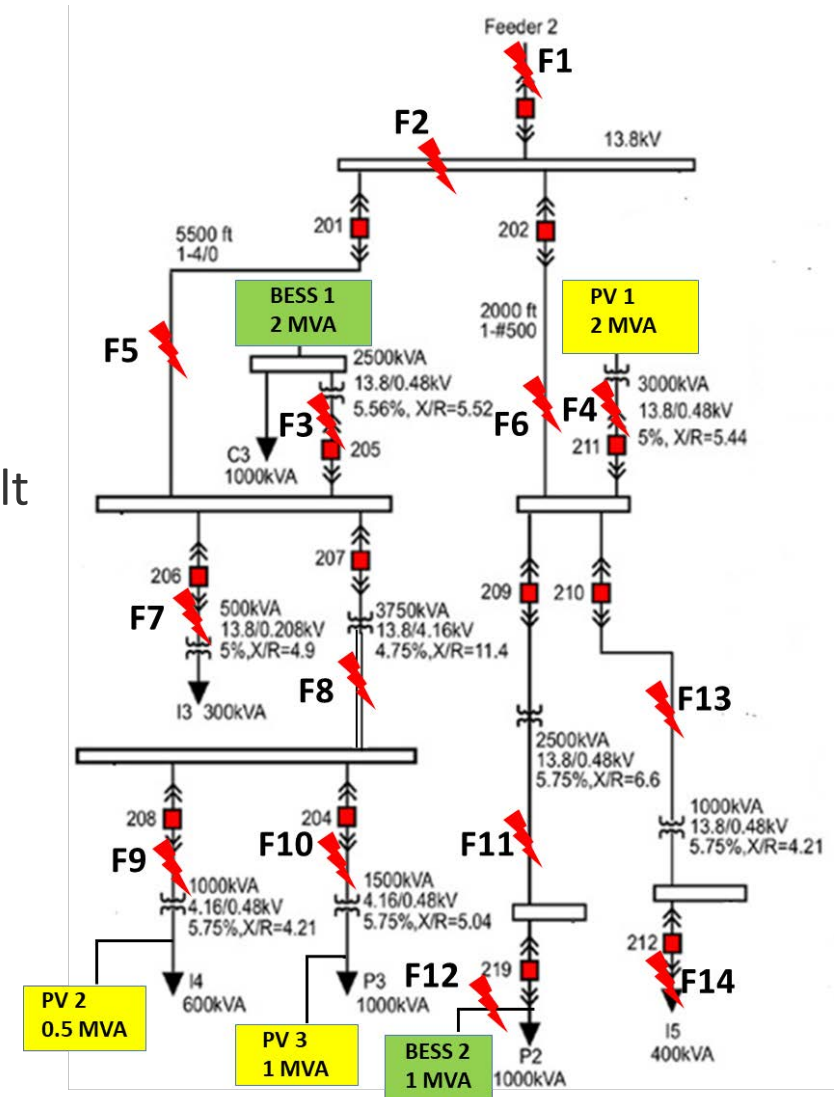

# Protection Design— Define Relay Category

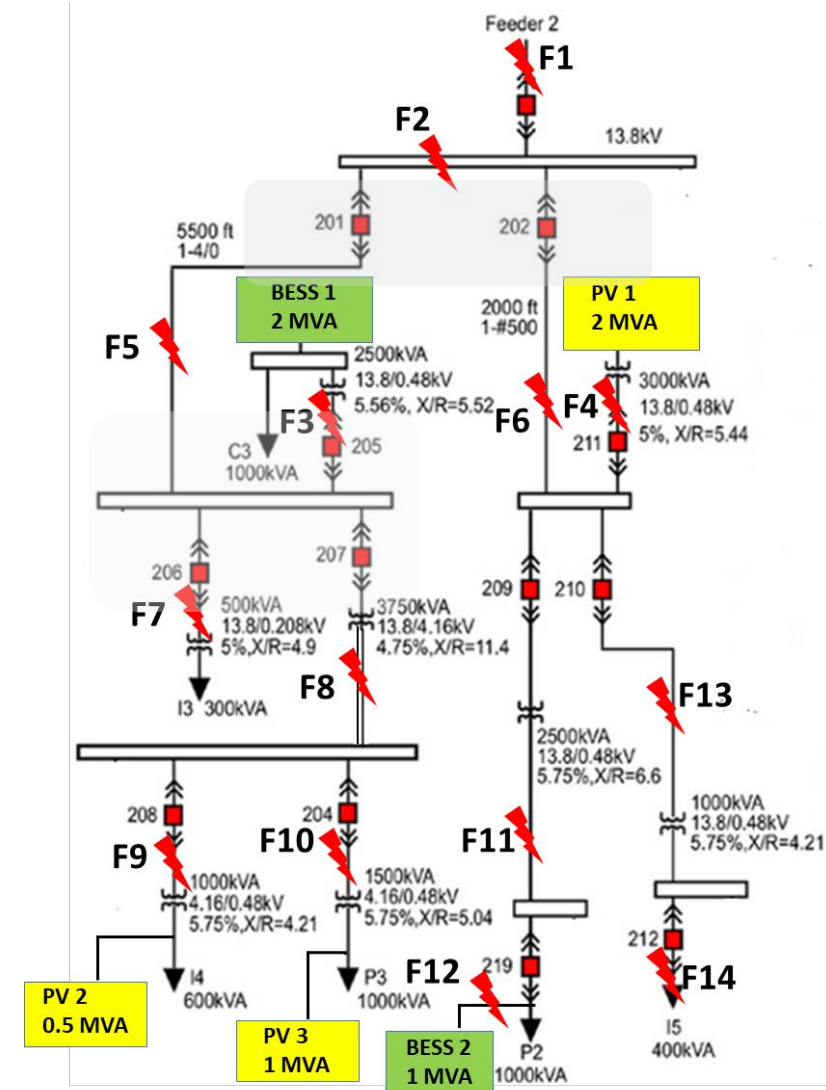
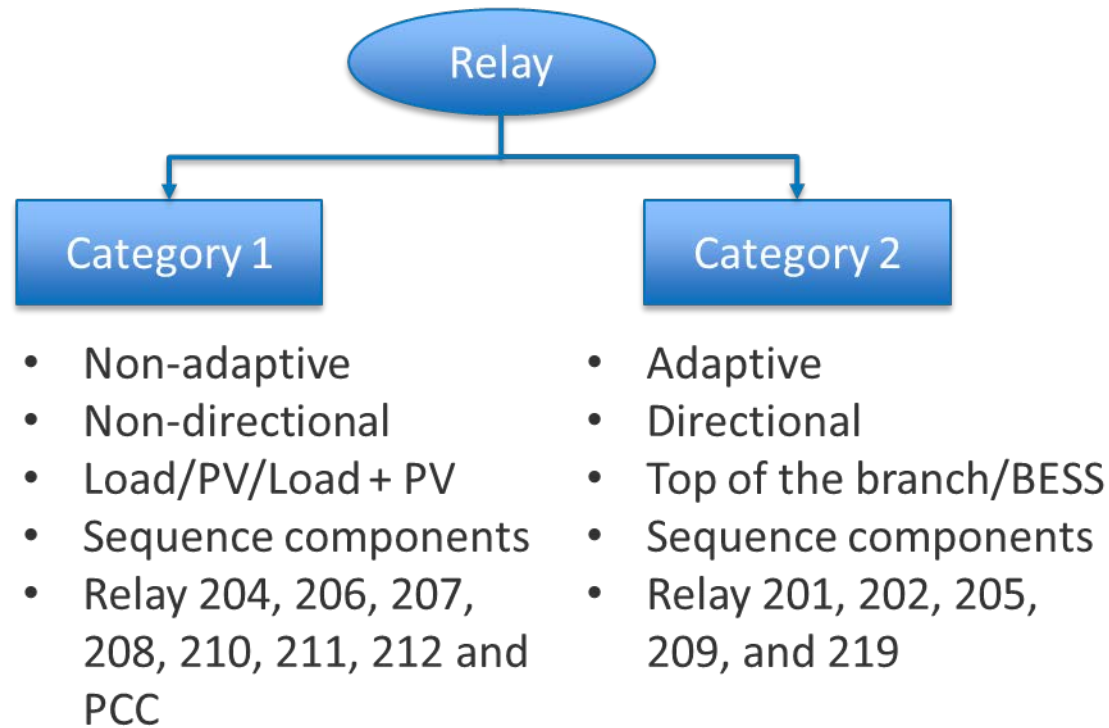

# Protection Design— Communication Based

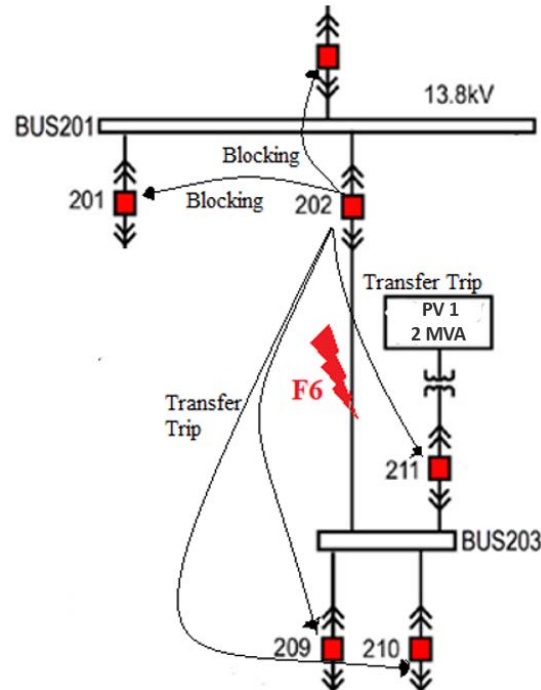
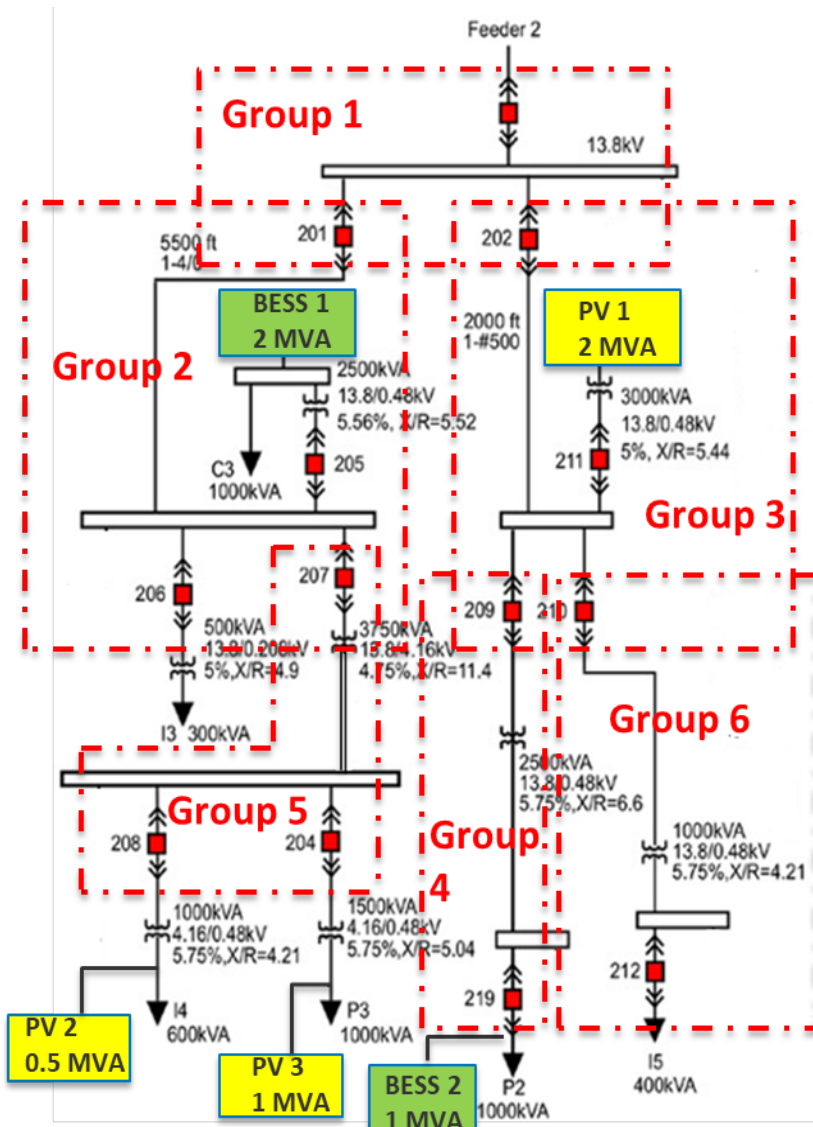

- Transfer-trip signal:
  - Confirm the faulty zone.
  - Send the transfer-trip signal to adjacent downstream relays.
- Blocking signal:
  - Avoid sympathetic tripping.
  - Receive the blocking signal from the responsible relay to avoid unnecessary tripping.
- PCC circuit breaker status:
  - Relays in Group 1 further transmit it to relays in adjacent groups.



# Protection Design— Direction Elements

$$T^+ = V^+ I^+ \cos (\angle V^+ - (\angle I^+ + \angle Z^+))$$

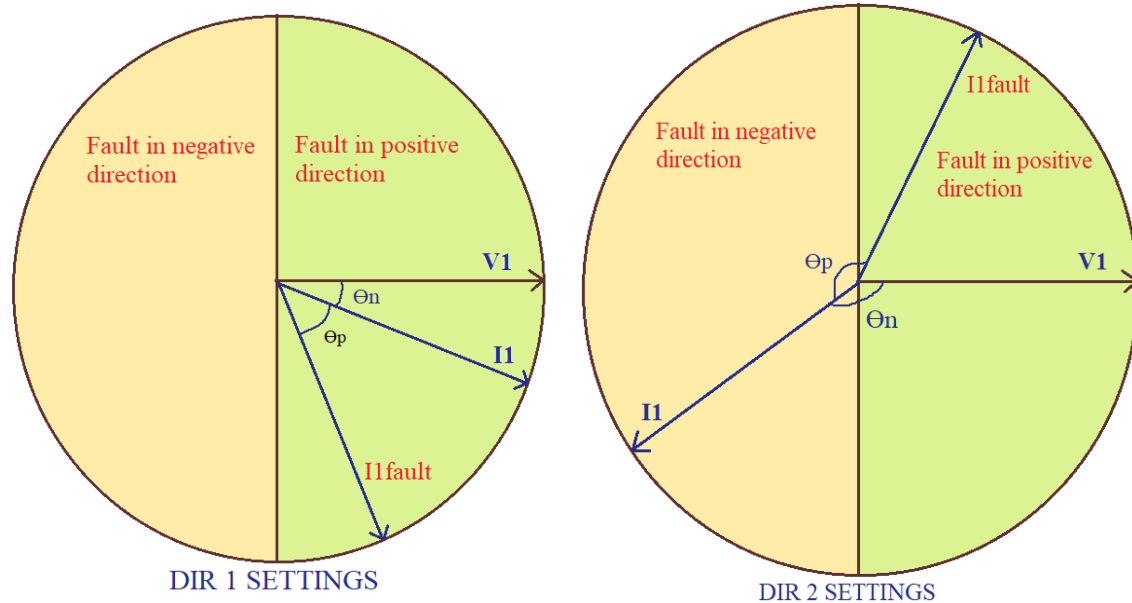

Settings	Normal Operating Phase Angle ( $\theta_n$ ) Degree	Phase Jump ( $\theta_p$ ) for Fault Detection in Forward Direction Degree	Phase Jump ( $\theta_p$ ) for Fault Detection in Reverse Direction
DIR 1	$-90 < \theta_n < 90$	$\theta_p < 90 - \theta_n$ : clockwise OR $\theta_p < 90 + \theta_n$ : anticlockwise	$\theta_p > 90 - \theta_n$ : clockwise OR $\theta_p > 90 + \theta_n$ : anticlockwise
DIR 2	$\theta_n < -90$ OR $\theta_n > 90$	$\theta_p > 270 - \theta_n$ : clockwise OR $\theta_p > \theta_n - 90$ : anticlockwise	$\theta_p < 270 - \theta_n$ : clockwise OR $\theta_p < \theta_n - 90$ : anticlockwise

Fault	Relay 201	Relay 202	Blocking Signal
F5	Forward	Reverse	Relay 202 to Relay 201
F6	Reverse	Forward	Relay 201 to Relay 202
F2	Reverse	Reverse	No blocking signal

- In grid-connected mode, relays only need to detect a fault in the forward direction.
- In islanded mode, relays with BESS connected only need to detect a fault in the forward direction.
- Relays 201 and 202 need to detect both directions.

# Protection Design— Sequence Components

- Category 1 relays:
  - With only load connected
  - With load and PV connected.
- Category 2 relays:
  - Grid-connected
  - Islanded.

Protection Settings of Category 1 Relays

Relay	Pickup	Relay	Pickup
204/208	$(I_1 > 2.5 \text{ p.u.}) \text{ OR } (I_1 > 1 \text{ p.u. AND } I_2 > 0.3 \text{ p.u.})$	210/212	$(I_1 > 0.8 \text{ p.u.}) \text{ OR } (I_1 > 0.4 \text{ p.u. AND } I_2 > 0.2 \text{ p.u.}) \text{ OR } (I_0 > 0.04 \text{ p.u. AND } I_2 > 0.04 \text{ p.u.})$
207	$(I_1 > 2.5 \text{ p.u.}) \text{ OR } (I_1 > 1.2 \text{ p.u. AND } I_2 > 1 \text{ p.u.})$	206	$(I_1 > 0.6 \text{ p.u.}) \text{ OR } (I_1 > 0.3 \text{ p.u. AND } I_2 > 0.2 \text{ p.u.})$

Protection Settings of Category 2 Relays in Grid-Connected Mode

Relay	Pickup	Relay	Pickup
201/202/205	$I_1 > 5 \text{ p.u. OR } I_2 > 1 \text{ p.u.}$	209	$(I_1 > 2.5 \text{ p.u.}) \text{ OR } (I_2 > 1.5 \text{ AND } I_2 > 1.5 \text{ p.u.})$
		219	$(I_1 > 1.5 \text{ p.u.}) \text{ OR } (I_2 > 0.9 \text{ AND } I_2 > 0.9 \text{ p.u.})$

Protection Settings of Category 2 Relays in Islanded Mode

Relay	Pickup	Relay	Pickup
201/202	$(I_1 > 2.5 \text{ p.u. OR } I_2 > 0.5 \text{ p.u. OR } I_0 > 0.5 \text{ p.u.}) \text{ AND } V_1 < 0.77 \text{ p.u.}$	219	$I_1 > 1.86 \text{ p.u. OR } (I_2 > 0.1 \text{ p.u. AND } I_2 < 0.8 \text{ p.u.})$
205	$I_1 > 2 \text{ p.u. OR } (I_2 > 0.1 \text{ p.u. AND } I_2 < 0.7 \text{ p.u.})$	209	$I_1 > 2.2 \text{ p.u. OR } (I_2 > 0.1 \text{ p.u. AND } I_2 < 2 \text{ p.u.})$



# Protection Design— Other Factors

- Time coordination among relays:
  - Grid-connected mode, both category 1 and 2 relays see single-direction fault currents.
  - Islanded mode, category 2 relays observe an abnormal current for all faults, thus longer waiting times.

Relay	TD	Relay	TD	Relay	TD	Relay	TD
201	1.5	205	0.5	208	0.5	211	0.5
202	1.5	206	0.5	209	1.5	212	0.5
204	0.5	207	1.5	210	1.5	219	0.5

Relay	TD	Relay	TD	Relay	TD	Relay	TD
201	3	R205	3	R208	0.5	211	0.5
202	3	R206	0.5	R209	3	212	0.5
204	0.5	R207	1.5	R210	1.5	219	3

- Rate of change:
  - Positive-sequence current ( $di_1/dt$ ).

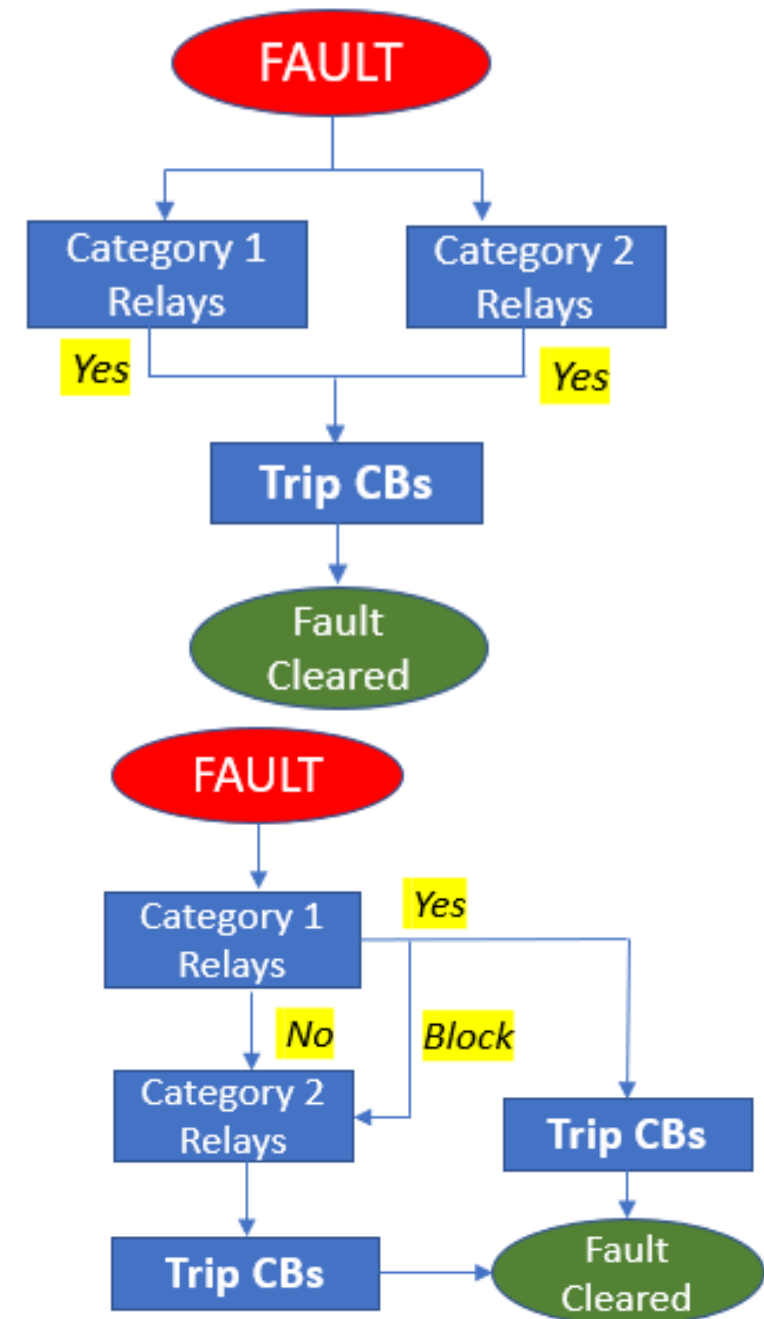



# Simulation Validation (Grid-Connected Mode)— Evaluation of Category 1 Relays With Fault F8

Relay 207: Sequence component of current (LLL fault)

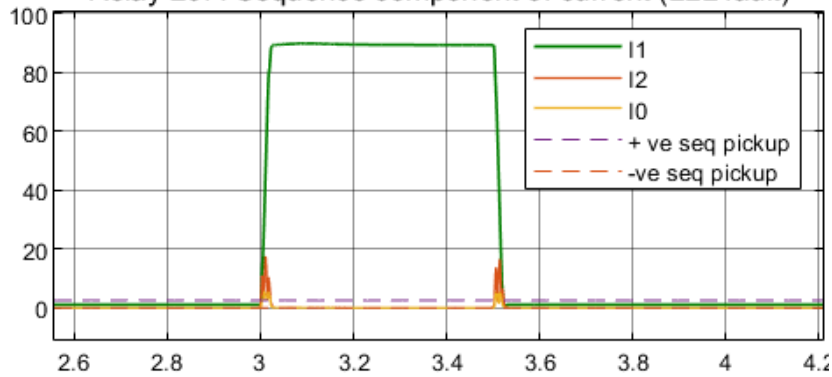

Relay 207: Sequence component of current (LL fault)

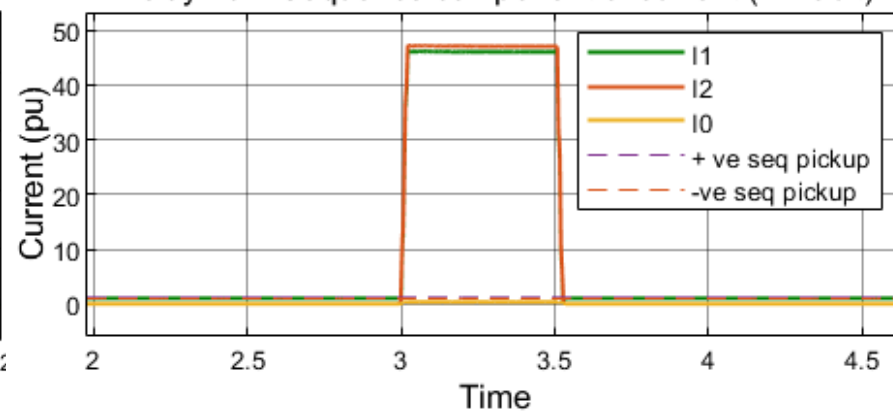

Relay 207: Sequence component of current (LG fault)

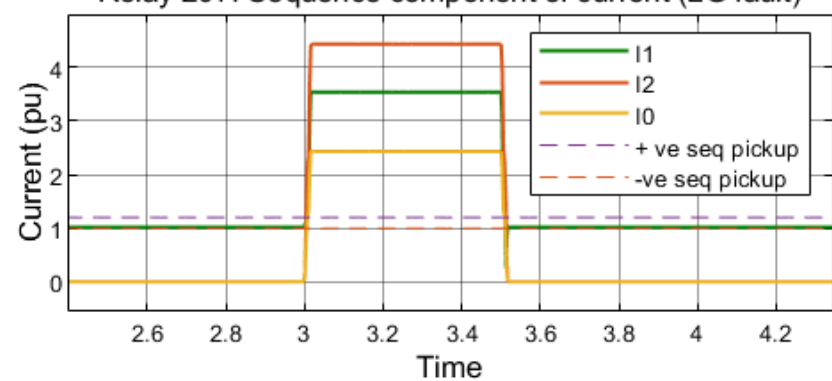

Relay 207: Sequence component of current (LLG fault)

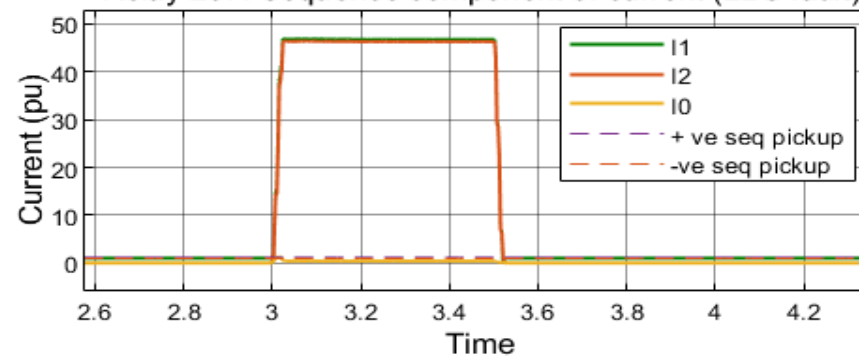

CB\_207\_Status

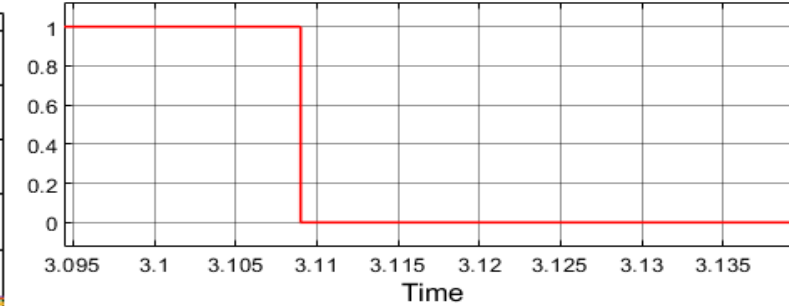

CB\_204\_Status

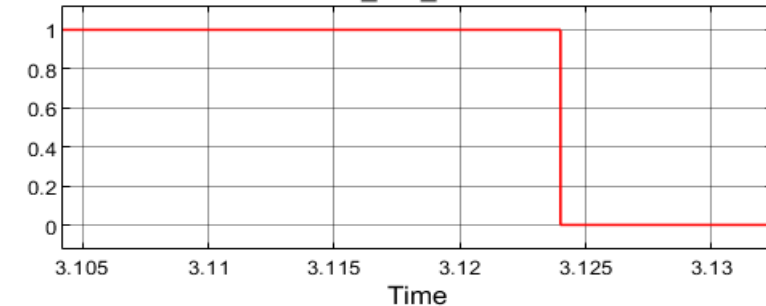

CB\_208\_Status

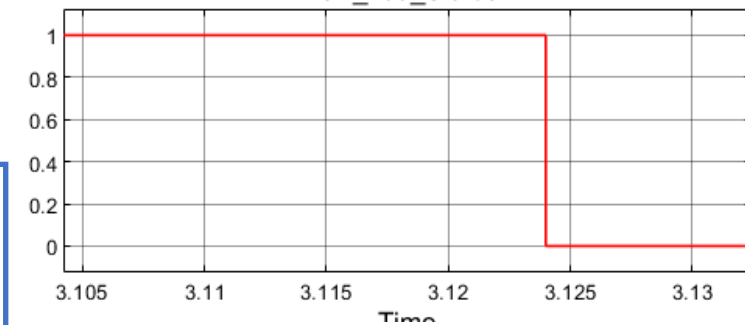

- There is no difference in full solar or no solar for the fault current level.
- Different fault types have an impact on the fault level.
- The circuit breaker operates as expected: Relay 207 detects the fault and then sends transfer-trip signals to downstream relays 204 and 208.

# Simulation Validation (Islanded Mode)— Evaluation of Category 1 Relays With Fault F8

Relay 207: Sequence component of current (LLL fault)

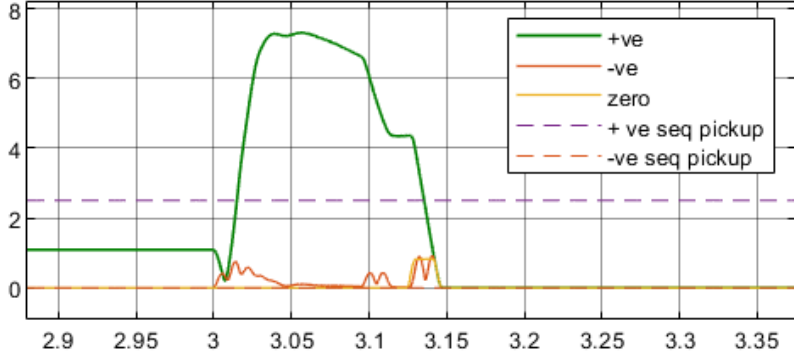

Relay 207: Sequence component of current (LL fault)

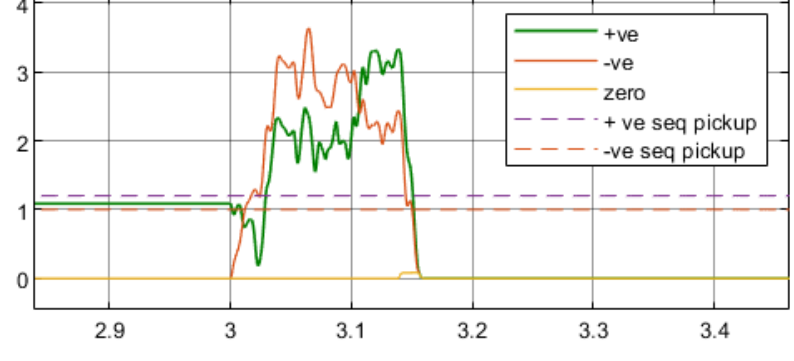

Relay 207: Sequence component of current (LLL fault)

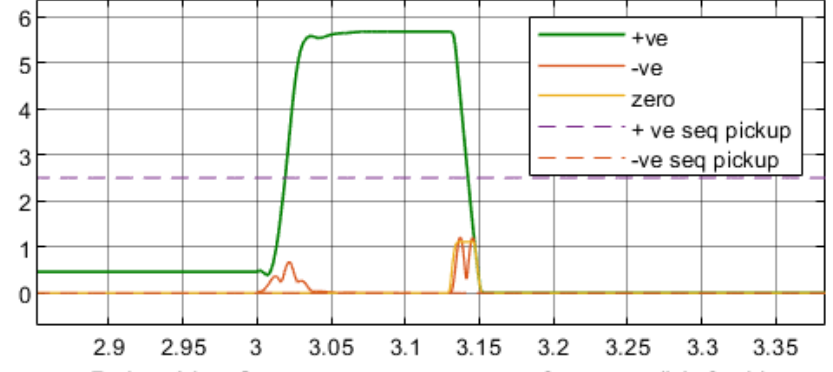

Relay 207: Sequence component of current (LLG fault)

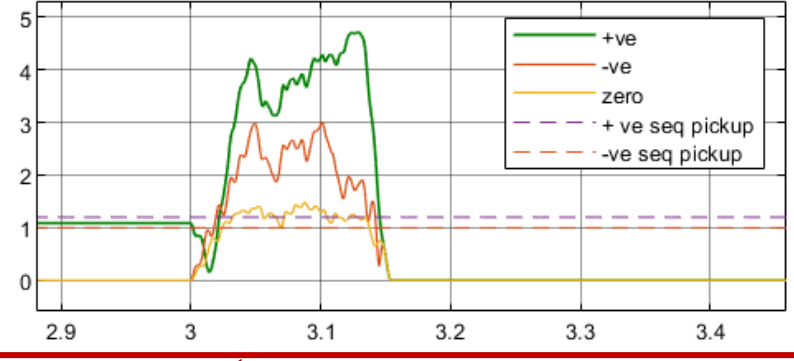

Relay 207: Sequence component of current (LG fault)

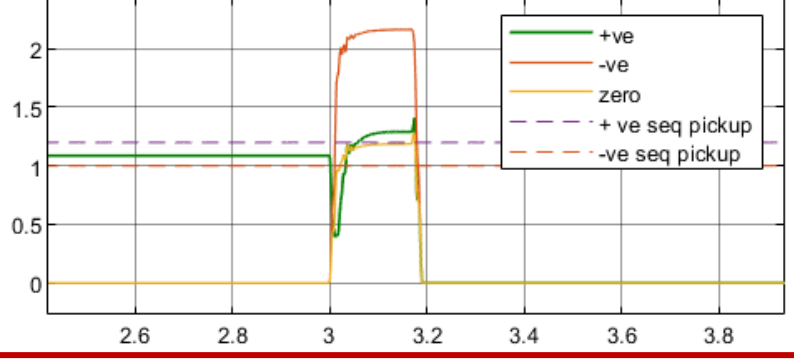

Relay 207: Sequence component of current (LL fault)

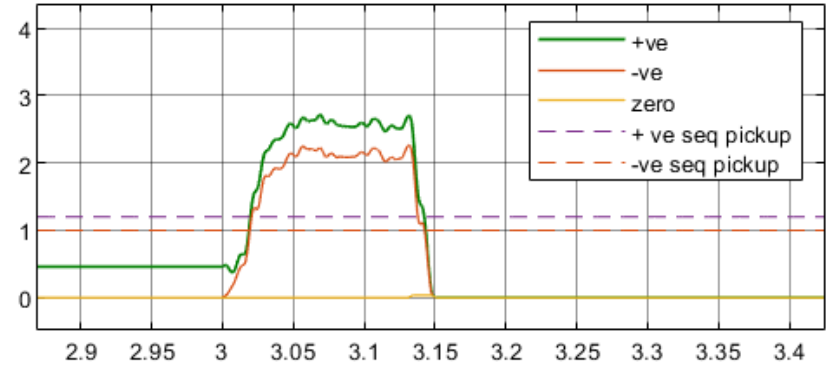

Relay 207: Sequence component of current (LLG fault)

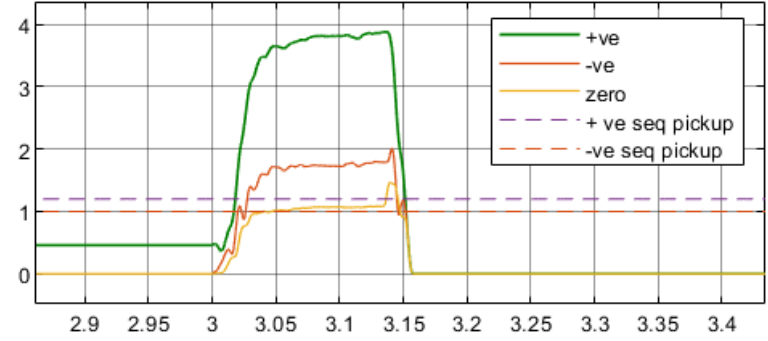

Relay 207: Sequence component of current (LG fault)

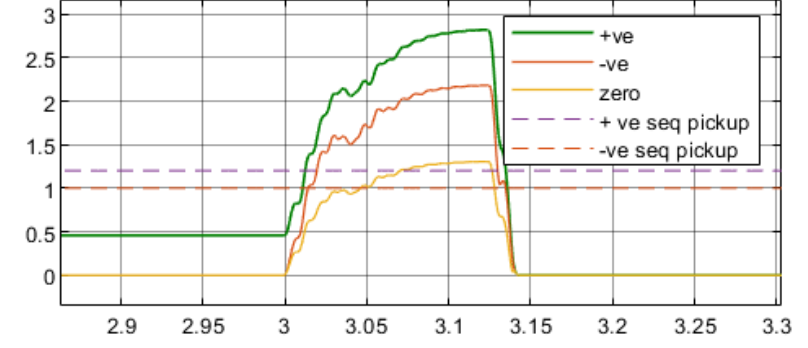

Full solar

No solar

# Simulation Validation (Islanded Mode)— Evaluation of Category 1 Relays With Fault F8

Relay 204: Transfer trip from Relay 207

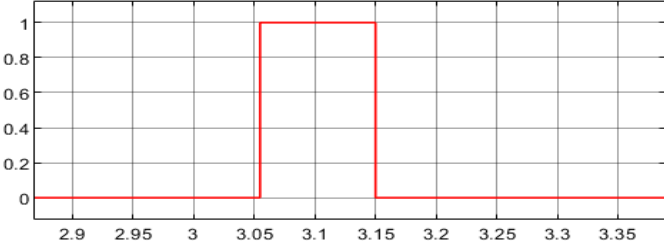

Relay 208: Transfer trip from Relay 207

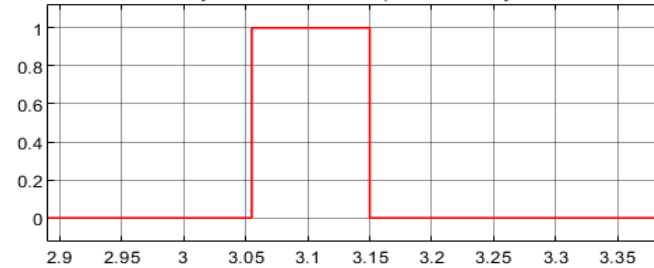

CB\_207\_Status

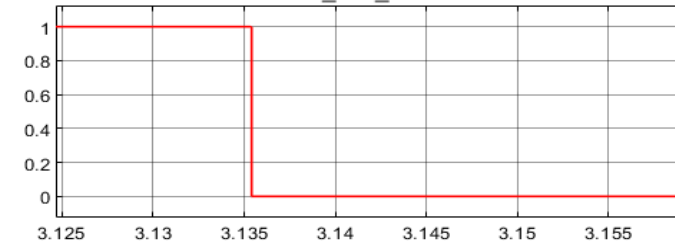

CB\_204\_Status

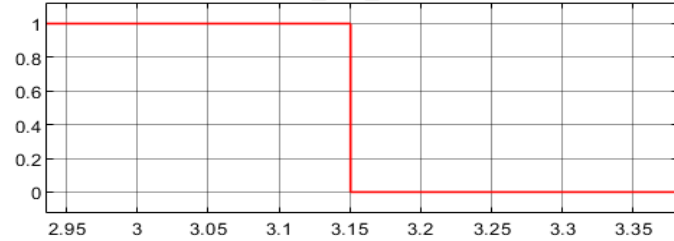

CB\_208\_Status

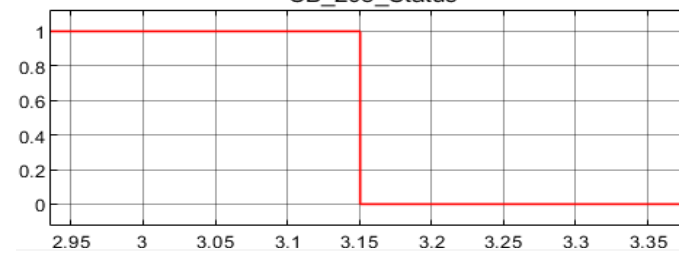

## LL fault with full solar

- Relays operate as expected:
  - CB-207 trips at 3.136 s, 8.16 cycles after fault with 5-cycle mechanical delay
  - CB-204 and CB-208 trip at 3.15 s, 9 cycles after fault with 5-cycle mechanical delay.
- Response of IBRs:
  - Both Battery 1 and PV 1 return to normal operation after the fault is cleared.

Battery 1 Voltage

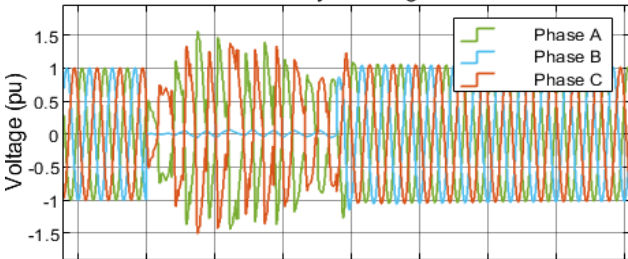

V\_pu\_PV1

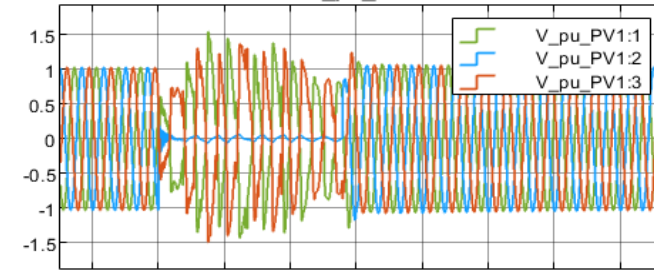

BESS 1 Output Current

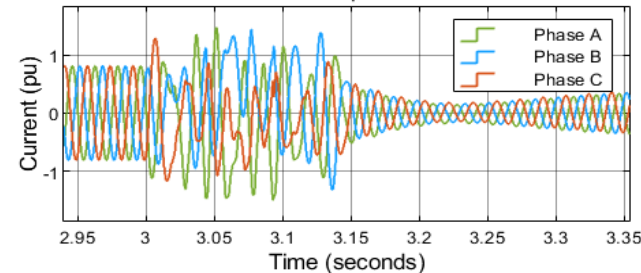

PV 1 Output Current

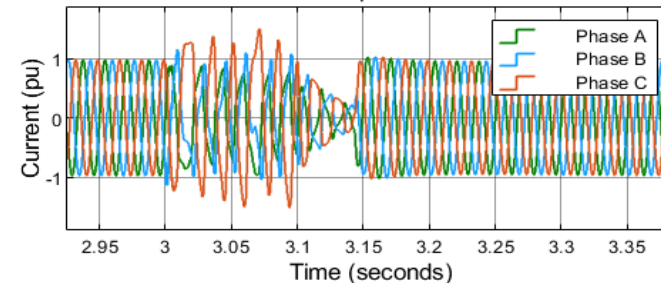

# Simulation Validation (Grid-Connected Mode)— Evaluation of Category 2 Relays With Fault F2

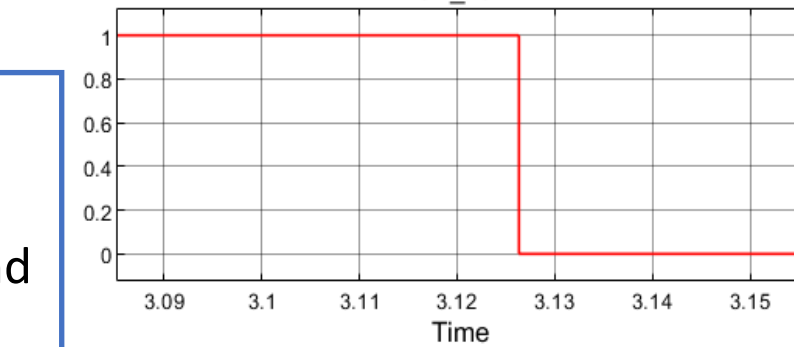
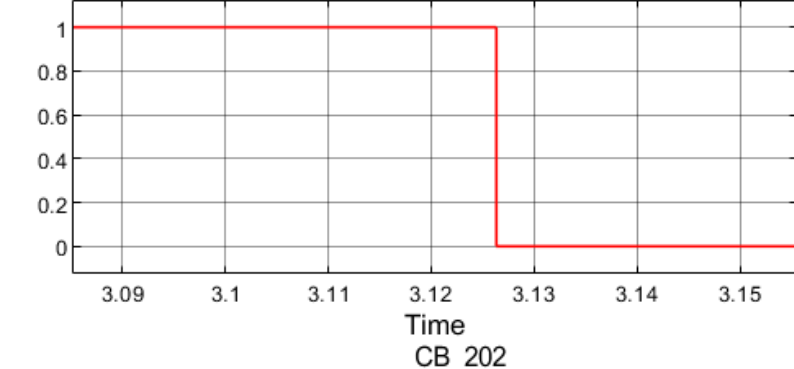
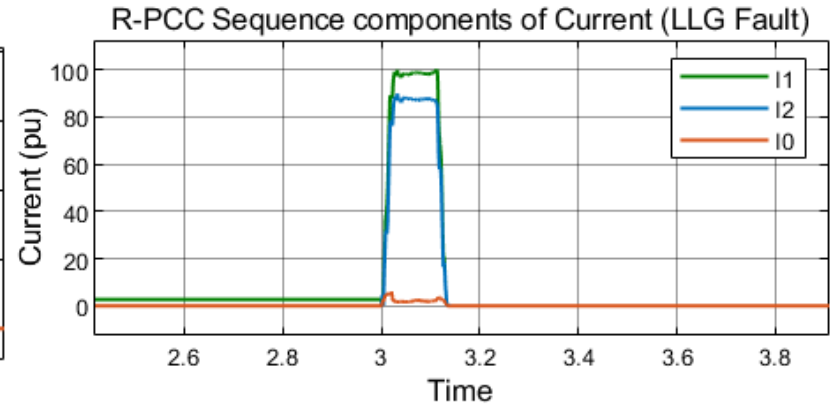
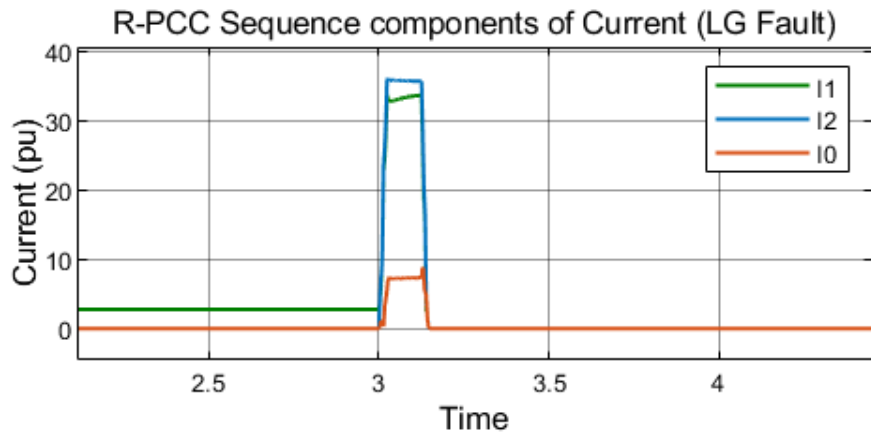
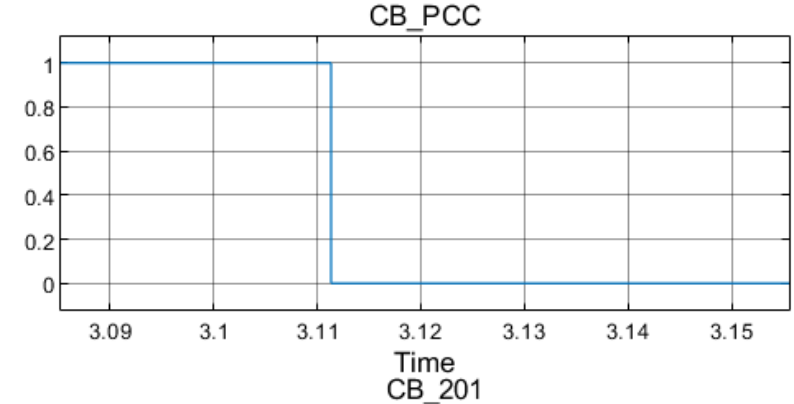
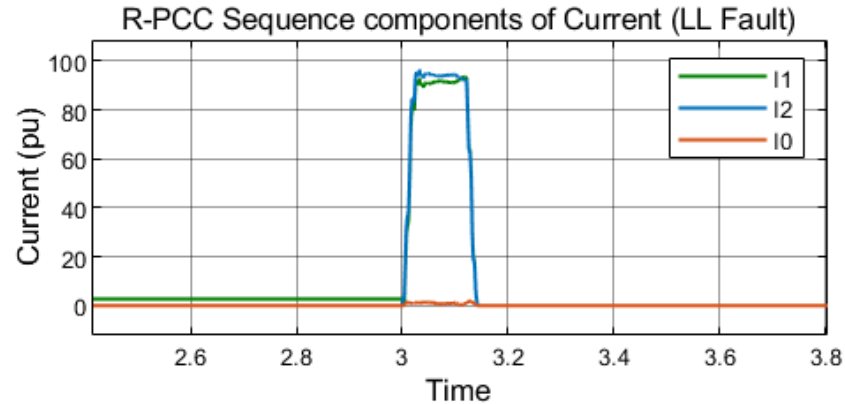
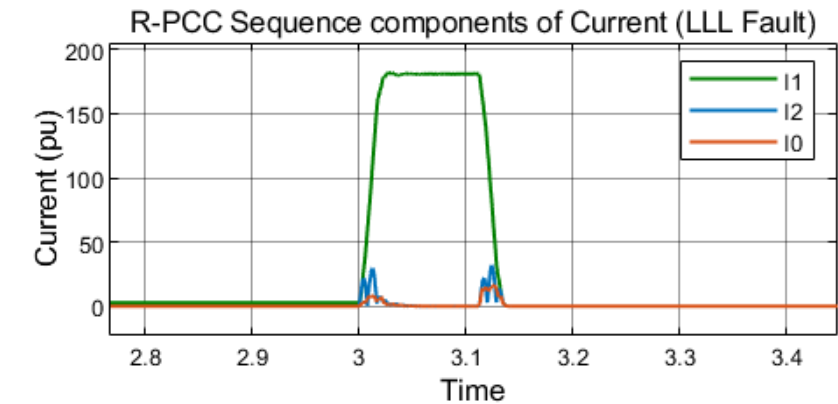

- There is no difference in full solar or no solar for the fault current level.
- Different fault types have an impact on the fault level.
- The circuit breaker operates as expected: The PCC relay detects the fault and then sends transfer signals to downstream relays 201 and 202.



# Simulation Validation (Islanded Mode)— Evaluation of Category 2 Relays With Fault F2

Relay	Solar	Pre-Fault Phase Angle	Settings	Post-Fault Phase Angle	Phase Jump (Degree)	Fault Direction
201	No	220	DIR 2	-100	40 clockwise	Reverse
202	No	55	DIR 1	170	115 clockwise	Reverse
201	Full	30	DIR 1	-100	130 anticlockwise	Reverse
202	Full	200	DIR 2	180	20 anticlockwise	Reverse

- Relays operate as expected:
  - CB-201 and CB-202 trip at 3.175 s, 10.5 cycles after the fault with 5-cycle mechanical delay
  - No blocking signals are received by the relays.

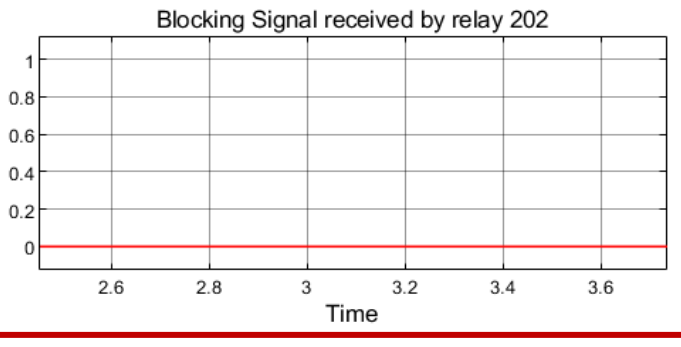
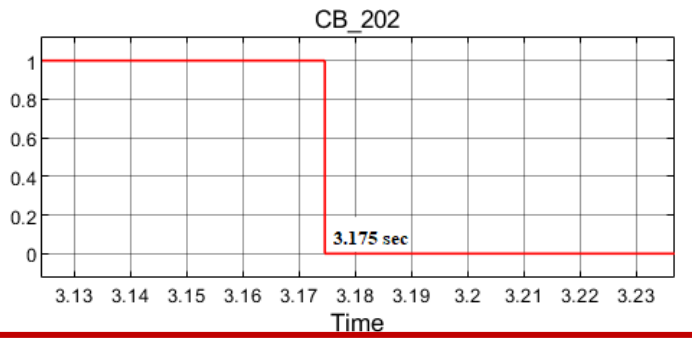
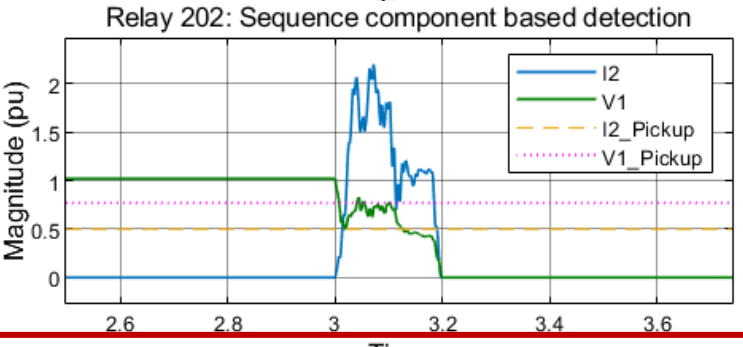
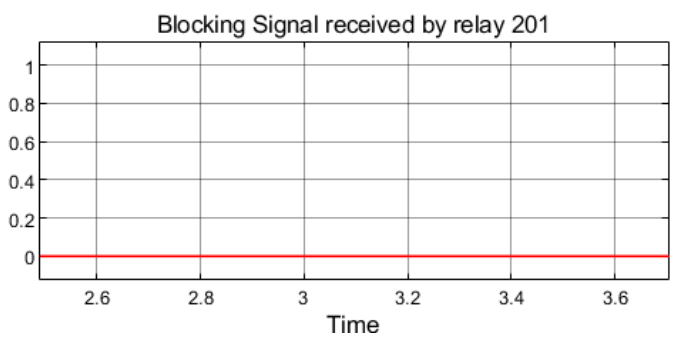
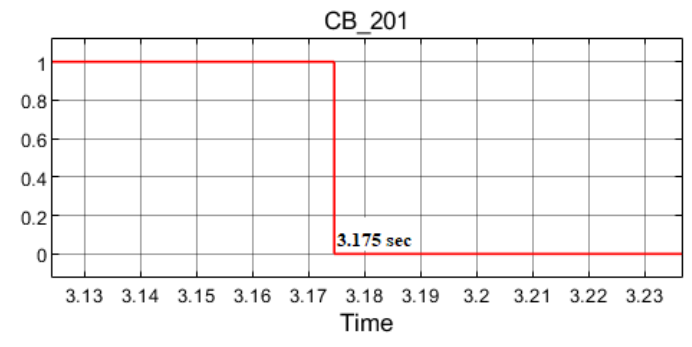
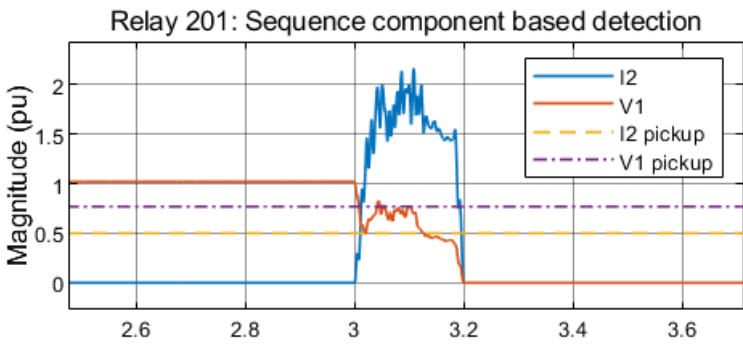

Full solar

# Recap of the Protection Design and Performance Evaluation

- Protection design:
  - Category 1 (Load-PV) relay logic can detect most faults in different scenarios. Category 2 relays need to be tested more rigorously, and modifications are needed, as necessary.
  - The IBRs' IEEE 1547 compliance affects the fault response, but traditional protection still functions.
  - In general, the workflow can be used for other microgrids.
- Performance evaluation:
  - The protection design is tested under various load and PV profiles. Due to the limited fault current in islanded mode, it is challenging to design protection logics that work under all scenarios of solar irradiance.
  - Some faults are difficult to detect, such as line-to-ground (LG) faults F3, F11, and F12. This is because these faults are in the delta side of the interconnecting transformer of the DERs.
  - **Limitations:** Does not function well under various solar irradiances, high-impedance faults, and unbalanced loads, and it needs to be tested under more scenarios and differentiated from disturbance events.

A data-driven-based approach is needed to resolve these limitations!



# Data-Driven Protection

- **Data-driven protection has been an active area of research for the past few years:**
  - Fault identification can be modeled as an anomaly detection problem [1].
  - Estimation of the location of the fault in a line can be modeled as a regression problem [2].
  - Fault localization in a network (microgrid) can be modeled as a classification problem, where each location in the network is the responsibility of a specific relay [this work and [3]].

## **Most data-driven protection approaches, however, suffer from:**

1. Data sets of faults that are not representative of all possible operational conditions:
  - Machine learning models trained on specific operational conditions are not guaranteed to perform well when the operational conditions change.
  - Varying fault parameters require the machine learning models to learn from diverse faults scenarios.
2. Centralization: Learning methods often require all measurements to be collected at a central location to be processed by the machine learning algorithm.

[1] Alireza Forouzesh et al., "Support Vector Machine-Based Fault Location Identification in Microgrids Using Interharmonic Injection," *Energies* 14.8 (2021): 2317.

[2] Jiefeng Liang et al., "Two-Terminal Fault Location Method of Distribution Network Based on Adaptive Convolution Neural Network," *IEEE Access* 8 (2020): 54,035–54,043.

[3] Shuva Paul et al., "Knowledge-Based Fault Diagnosis for a Distribution System with High PV Penetration," presented at the 2022 IEEE Power & Energy Society Innovative Smart Grid Technologies Conference (ISGT).

# Data-Driven Approach Overview

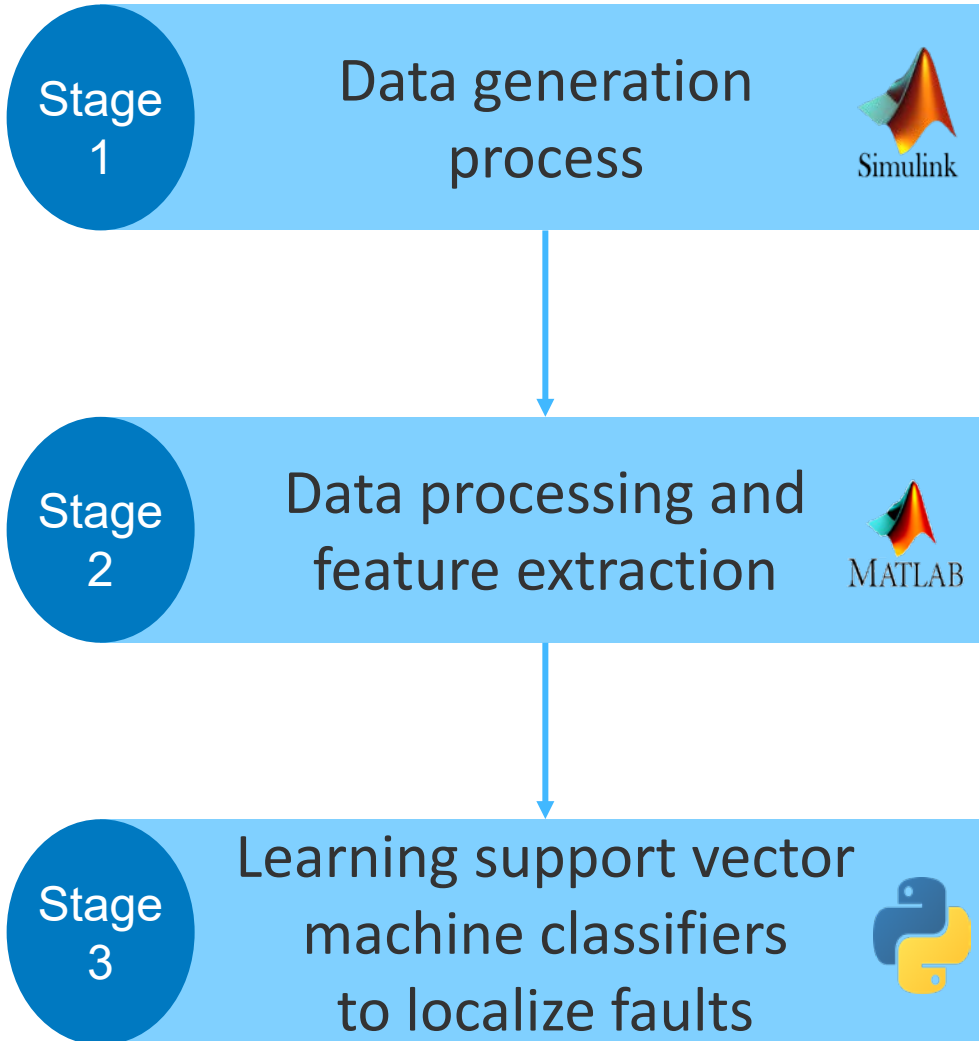

- **Fault signatures are recorded under varying:**
  - Fault location, type, impedance
  - Loading conditions and renewable generation
  - Microgrid operational mode, e.g., islanded and grid-connected
  - PV control mode.
- **Recorded signals are post-processed to obtain:**
  - Positive-, negative-, and zero-sequence components
  - dq0 components
  - Harmonics in voltage and currents.
- **Assign data to each relay to learn from.**
- **Train multiple classifiers where each classifier is to be deployed at a specific relay.**
- **Assess the performance of classifiers individually and the performance of the whole approach.**

# Data Generation Process

Fault scenarios are simulated in Simulink with varying:

- Fault parameters:
  - Fault location, discrete uniform over locations
  - Fault type, discrete random over types
  - Fault impedance, beta distribution with two peaks
  - Fault time, uniform continuous.
- Operational conditions:
  - Solar irradiance, from annual real data
  - loading conditions, from annual real data
  - Inverter operational modes, discrete uniform over modes.

For each scenario, the measurements of each relay are collected to be preprocessed before being used by the machine learning approach.

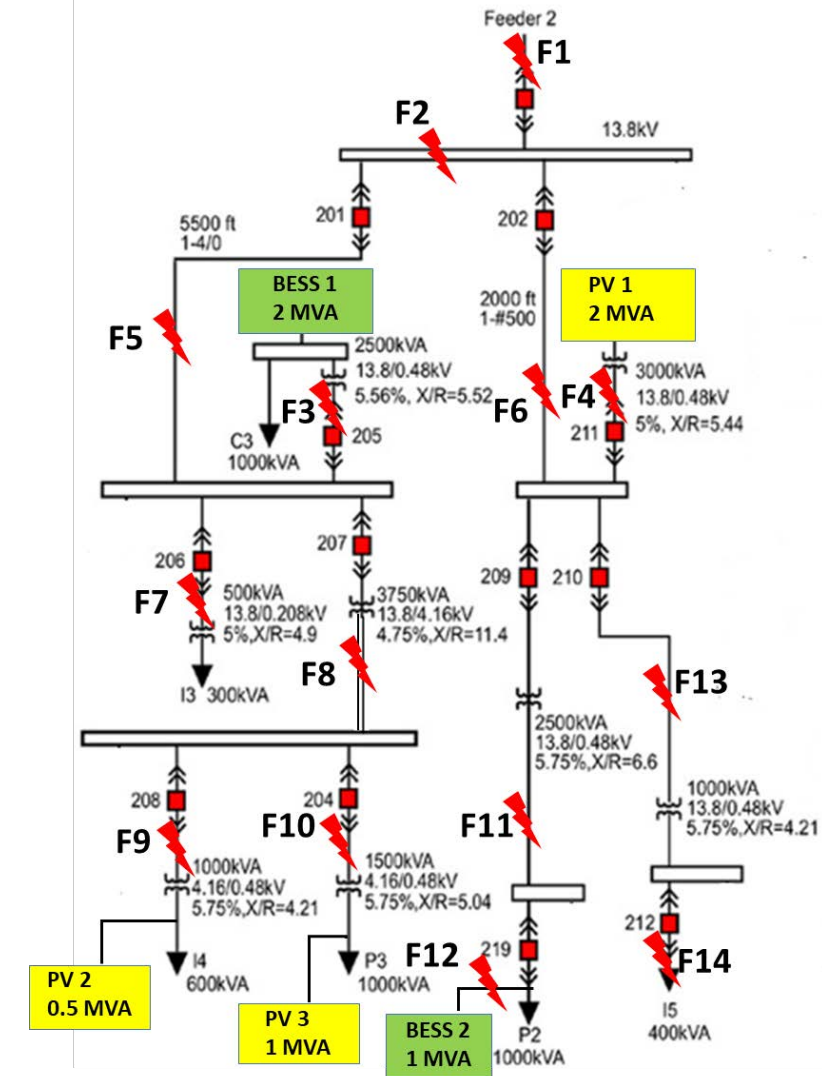

# Localized Fault Detection and Classification

- An issue for data-driven protection schemes is the inability to differentiate fault locations.
- Faults at different locations can have the same exact response seen by a specific relay (**non-identifiable signatures**).
- For example, relay CB-219 observes the same response for F6 and F11. These two faults should have two totally different responses from CB-219.
- This calls for a coordination mechanism that can delay or block tripping of relays that cannot clear a specific fault.
- In the figure, we show the positive-sequence voltage, current, and impedance phase for F6 and F11.

Fault 11 @CB219

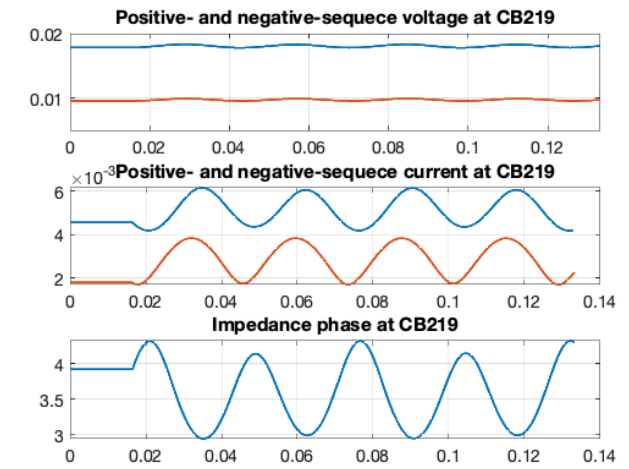

Fault6 @CB207

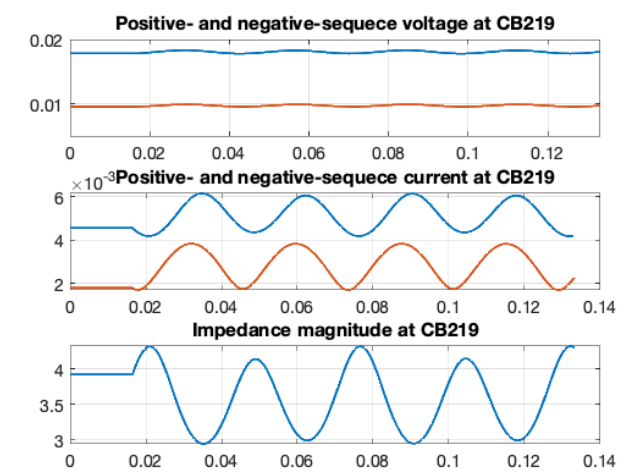

# Coordinated Data-Driven Fault Localization

- For indistinguishable fault signatures, we propose a coordinated data-driven fault localization approach.
- We **simplify** the task of classification at each relay to classify the direction of the fault, i.e., **upstream** and **downstream** faults.
- In this approach, the coordination is done in two stages:
  - Measurements sharing: Each relay communicates with the neighboring relays' measured voltages and currents. This enables the relays to accurately classify faults.
  - Decision rules: Relays decide on the location of the fault based on classifications at all neighboring relays.

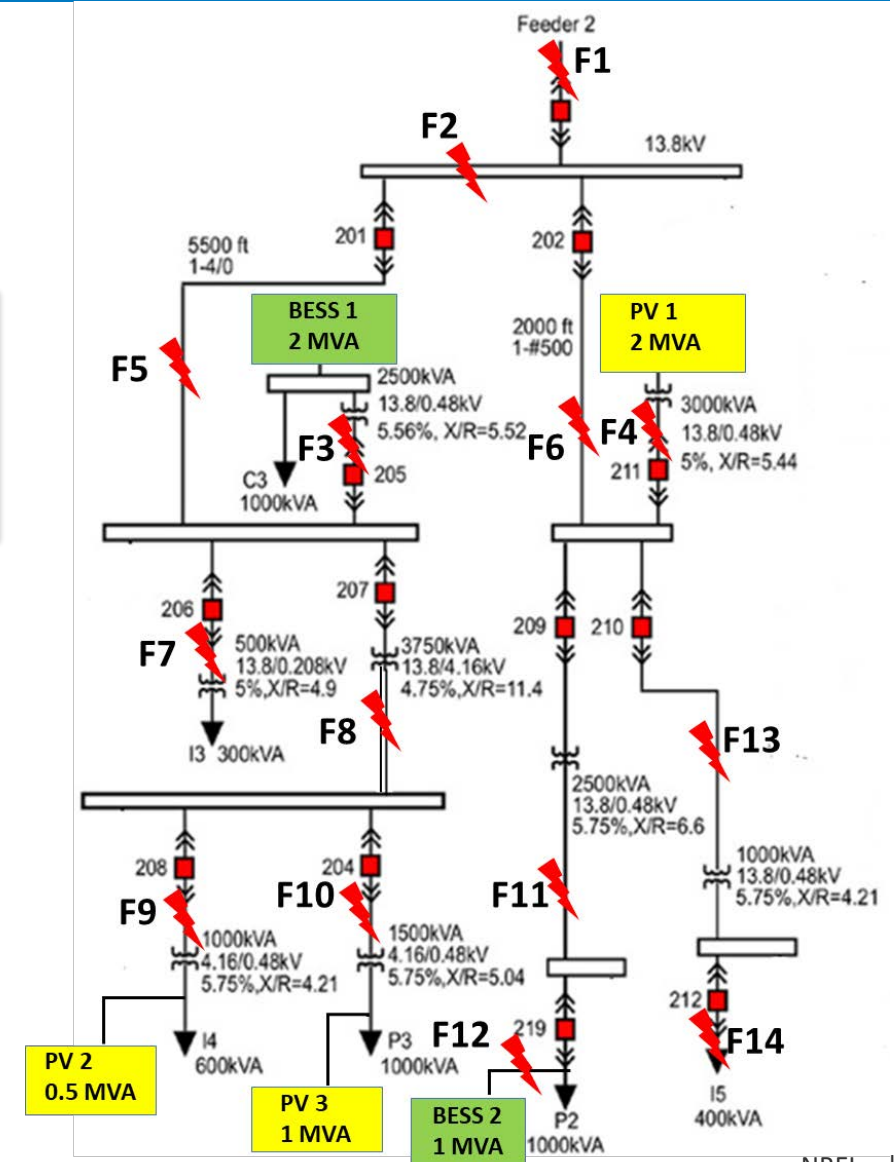

# Measurements Sharing

- In this stage measurements are shared between neighboring relays.
- Relays can distinguish faults if given measurements at the neighboring relays too.

	201	202	204	205	206	207	208	209	210	211	212	219
201	Black	Black	Light Blue	Black	Black	Black	Light Blue	Light Blue	Light Blue	Light Blue	Light Blue	Light Blue
202	Black	Black	Light Blue	Light Blue	Light Blue	Light Blue	Black	Black	Black	Black	Light Blue	Light Blue
204	Light Blue	Light Blue	Black	Light Blue	Light Blue	Black	Black	Light Blue	Light Blue	Light Blue	Light Blue	Light Blue
205	Black	Light Blue	Light Blue	Black	Black	Black	Light Blue	Light Blue	Light Blue	Light Blue	Light Blue	Light Blue
206	Black	Light Blue	Light Blue	Black	Black	Black	Light Blue	Light Blue	Light Blue	Light Blue	Light Blue	Light Blue
207	Black	Light Blue	Black	Black	Black	Black	Light Blue	Light Blue	Light Blue	Light Blue	Light Blue	Light Blue
208	Light Blue	Light Blue	Black	Light Blue	Light Blue	Black	Black	Light Blue	Light Blue	Light Blue	Light Blue	Light Blue
209	Light Blue	Black	Light Blue	Light Blue	Light Blue	Light Blue	Black	Black	Black	Black	Black	Black
210	Light Blue	Black	Light Blue	Light Blue	Light Blue	Light Blue	Black	Black	Black	Black	Black	Black
211	Light Blue	Black	Light Blue	Light Blue	Light Blue	Light Blue	Black	Black	Black	Black	Light Blue	Light Blue
212	Light Blue	Light Blue	Light Blue	Light Blue	Light Blue	Light Blue	Light Blue	Light Blue	Black	Black	Black	Black
219	Light Blue	Light Blue	Light Blue	Light Blue	Light Blue	Light Blue	Light Blue	Black	Light Blue	Light Blue	Light Blue	Black

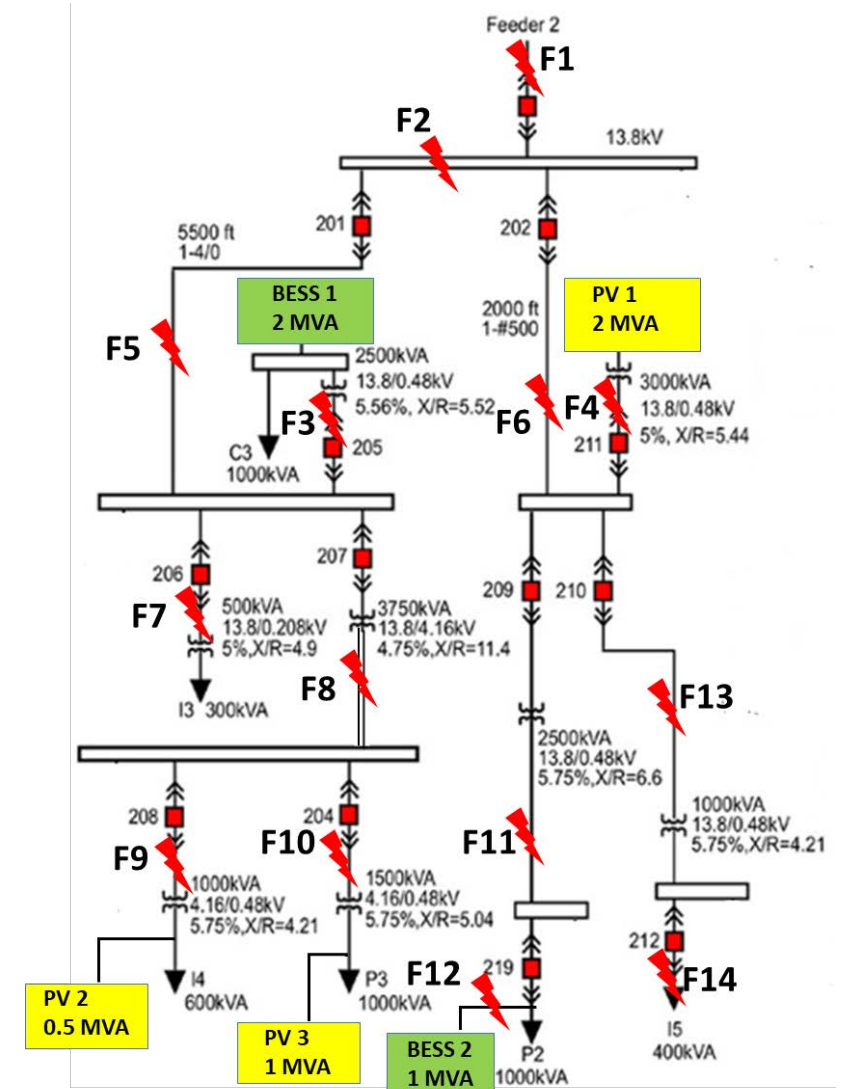



# Hierarchical Fault Localization

## Decision Zone #1:

- Fault 2 detection
- Left branch fault (Decision Zone #2)
- Right branch fault (Decision Zone #4).

## Decision Zone #2:

- Fault 5, Fault 7, and Fault 3 detection
- Downstream from Relay 207 (Decision Zone #3).

## Decision Zone #3:

- Fault 8, Fault 8, and Fault 10 detection.

## Decision Zone #4:

- Fault 4 and Fault 6 detection
- Downstream from Relay 209 (Decision Zone #5)
- Downstream from Relay 210 (Decision Zone #6).

## Decision Zone #5:

- Fault 11 and Fault 12 detection.

## Decision Zone #6:

- Fault 13 and Fault 14 detection.

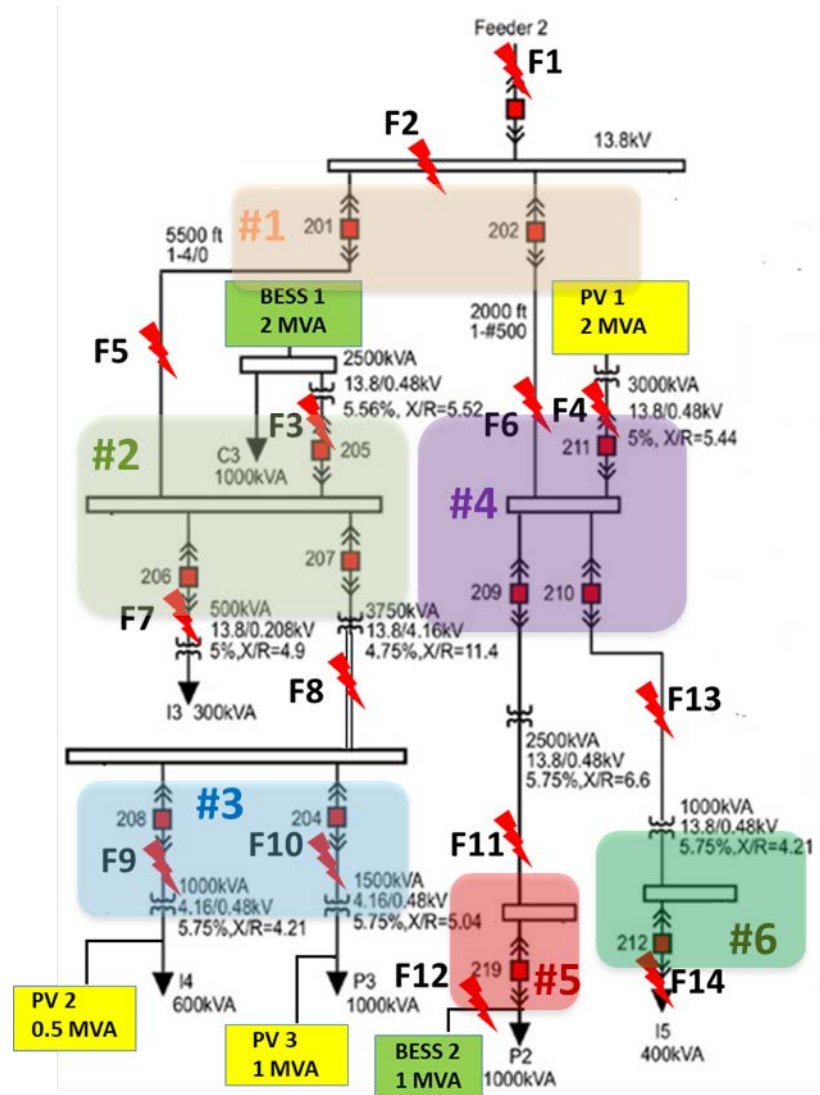

# Decision Zones #1, #2, and #3

## Decision Zone #1

CB201	CB202	Decision
0	0	F2
0	1	Zone 4
1	0	Zone 2
1	1	Inadmissible

## Decision Zone #2

CB205	CB206	CB207	Decision
0	0	0	F5
0	0	1	Zone 3
0	1	0	F7
0	1	1	Inadmissible
1	0	0	F3
1	0	1	Inadmissible
1	1	0	Inadmissible
1	1	1	Inadmissible

## Decision Zone #3

CB204	CB208	Decision
0	0	F8
0	1	F9
1	0	F10
1	1	Inadmissible

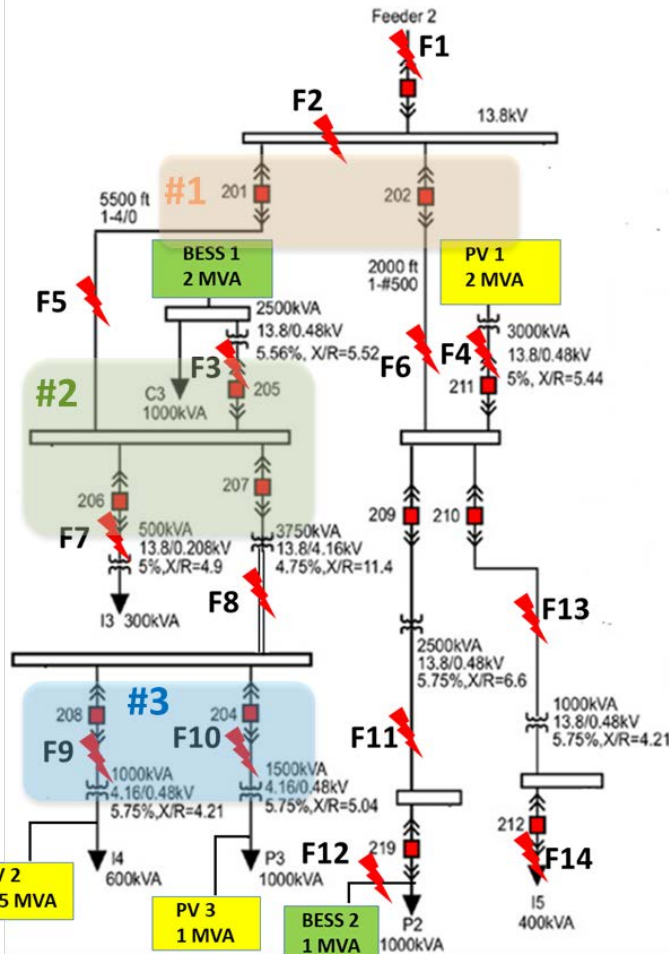



# Decision Zones #4, #5, and #6

## Decision Zone #4

CB209	CB210	CB211	Decision
0	0	0	F6
0	0	1	F4
0	1	0	Zone 6
0	1	1	Inadmissible
1	0	0	Zone 5
1	0	1	Inadmissible
1	1	0	Inadmissible
1	1	1	Inadmissible

## Decision Zone #5

CB219	Decision
0	F11
1	F12

## Decision Zone #6

CB212	Decision
0	F13
1	F14

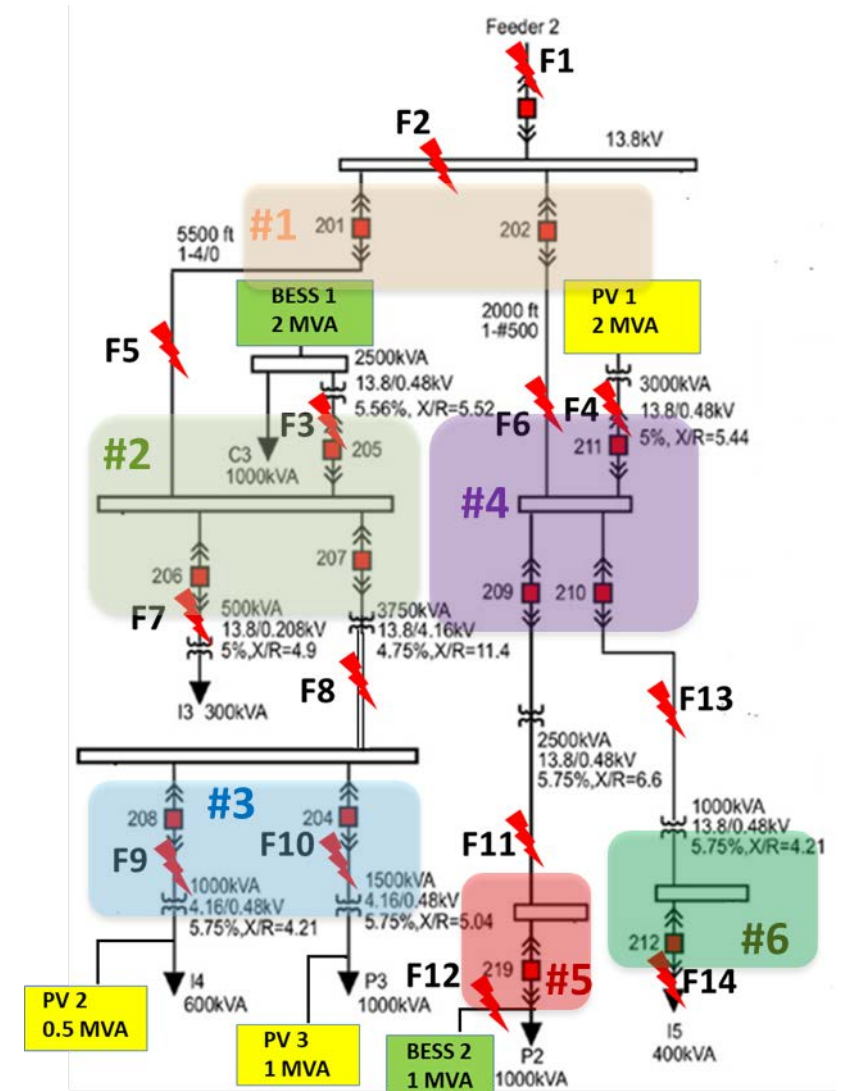

# Classification Performance for All Relays

- Automatic script runs 1,000 scenarios with 700 for training and 300 for testing.

- We use support vector machine classifier with polynomial kernels for all relays in the microgrid.

- Accuracy, precision, and recall are noticeably better for lateral relays.

- Optimizing the classifiers to obtain better performance.

Relay	Precision	Recall	Accuracy
R201	83.10%	69.41%	78.77%
R202	77.38%	80.25%	80.45%
R204	72.22%	76.47%	94.97%
R205	97.96%	100%	99.81%
R206	100%	100%	100%
R207	88.89%	66.67%	88.83%
R208	59.09%	72.22%	92.18%
R209	27.08%	54.17%	74.30%
R210	81.81%	93.10%	95.53%
R211	70%	70%	96.64%
R212	100%	100%	100%
R219	100%	60.53%	87.70%

# Classification Results for Faults

Decision Zone	Num. Relays	Accuracy
DZ #1	2	76.1%
DZ #2	3	82.6%
DZ #3	2	92.0%
DZ #4	3	73.7%
DZ #5	1	95.0%
DZ #6	1	99.3%

- Decision zones with more relays suffer due to the requirement that all classifiers perform accurately.
- The next step is to resolve inadmissible classification results: soft classification or maximum-likelihood estimators.

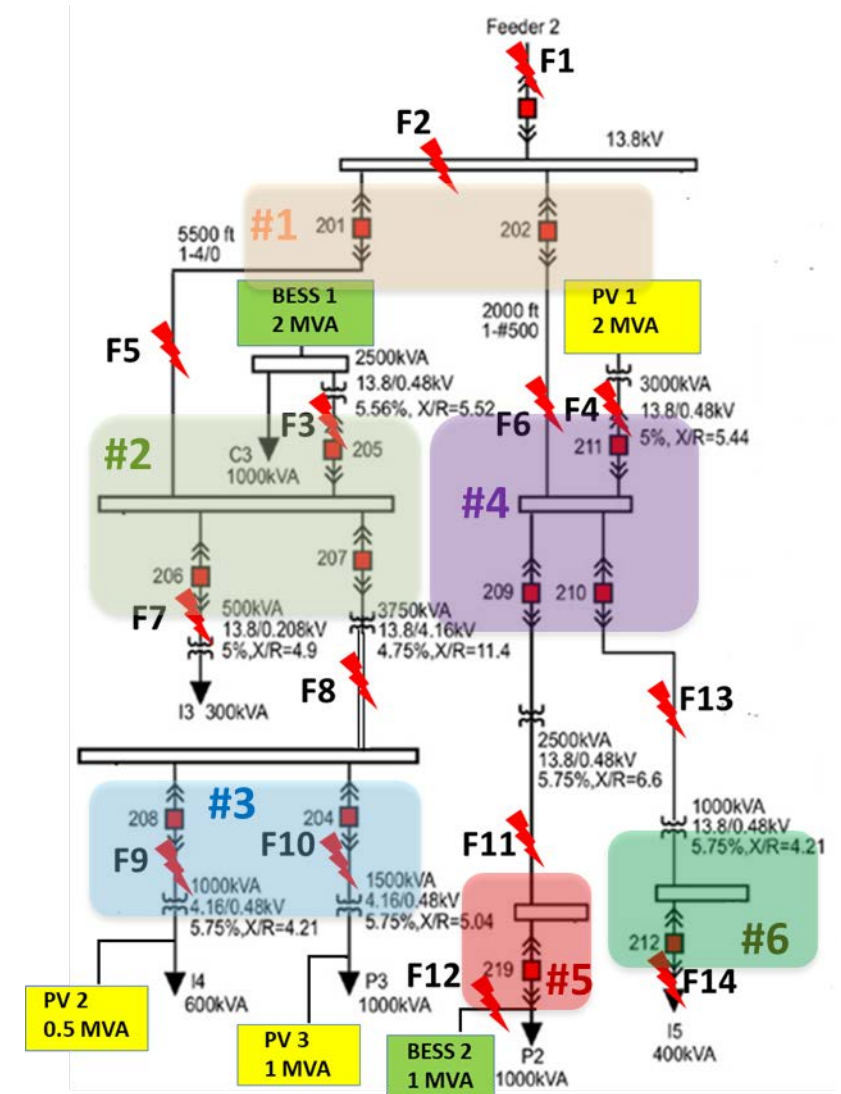

# Example Results and Performance

**Setup:** Run 1,000 scenarios with 700 for training and 300 for testing

**Accuracy:** 65%

## Fault 8:

- Relay 201 and Relay 202: **(1, 0)**  $\Rightarrow$  Decision Zone #2
- Relay 205, Relay 206, and Relay 207: **(0, 0, 1)**  $\Rightarrow$  Decision Zone #3
- Relay 204 and Relay 208: **(0, 0)**  $\Rightarrow$  **Fault 8.**

## Timing results:

- Localization time: 22.16 ms  $\pm$  9.9 ms (less than 2 cycles)
- Classification delay depends on the number of decision zones to be checked.
- Due to shifting all computations to offline learning stage, the decision time is very small.

## Observations:

- Classifiers at Relay 201 and Relay 202 are critically important.
- Dimensionality contributes to more accurate classifications.
- High-impedance faults require special quantities to be measured.

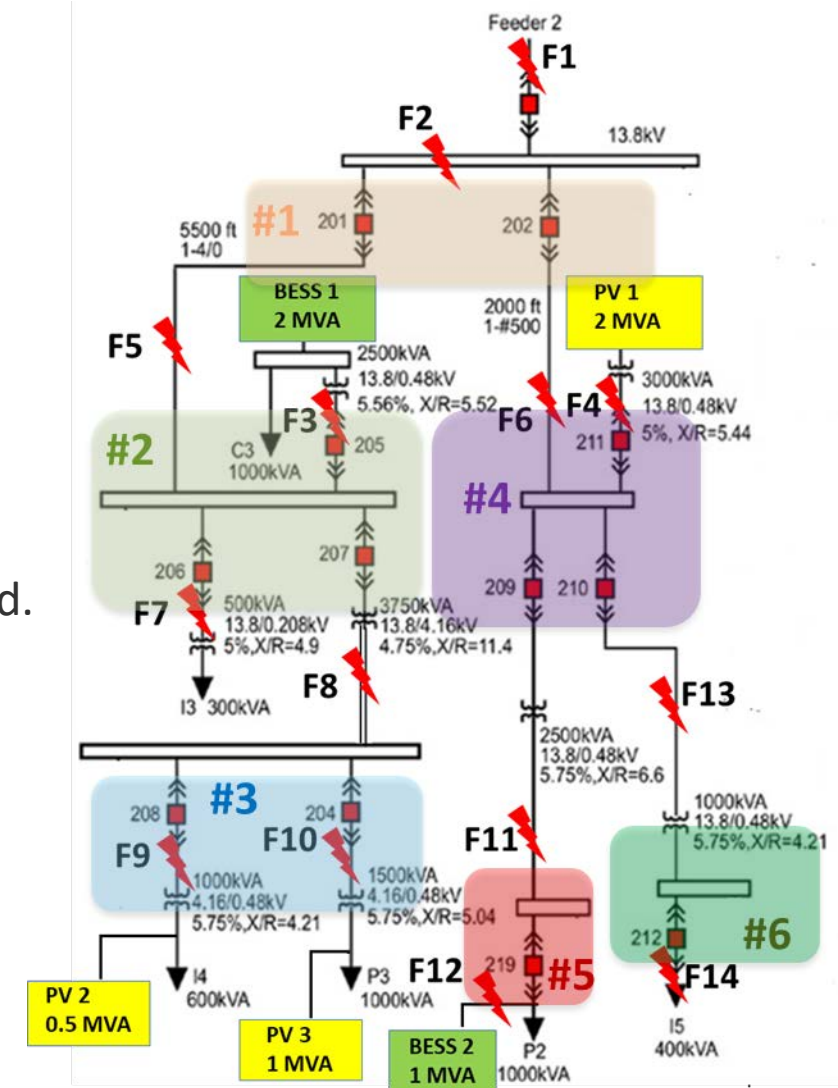

# Recap of Data-Driven Fault Location

- Data-driven protection approaches can handle situations that are challenging for traditional protection.
- Learning-based protection requires:
  - Careful design of communication between relays
  - The use of representative fault data samples
  - Design of simple learning tasks for local machine learning models.
- Designed a hierarchical localization approach to identify fault location based on layers of decision zones
- Achieved reasonable localization performance in situations including varying inverter operational modes and high-fault impedance.

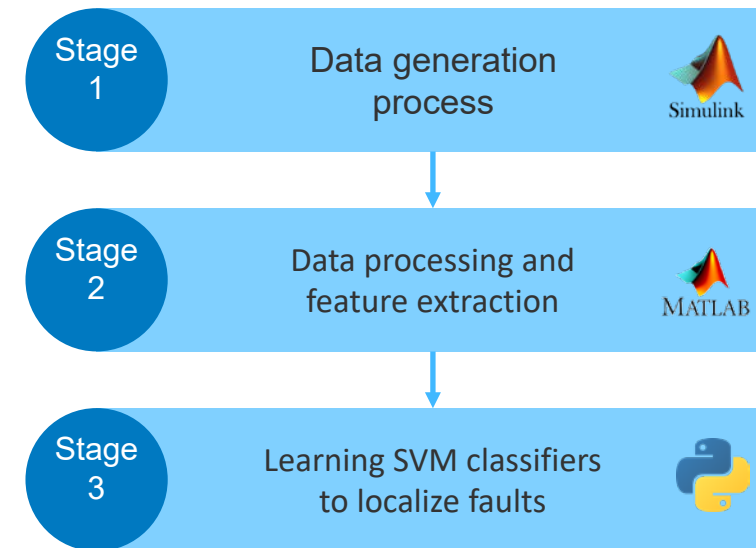

# Key Takeaways

- Protection challenges of 100% renewable microgrids:
  - Grid-connected and islanded operation mode might not be a challenge anymore.
  - IBR fault responses: changing and uncertain due to various factors from low fault current
  - Small line impedance, grounding ...
- Traditional protection needs additional protection functions:
  - Voltage RMS, positive-sequence voltage component
  - Negative-sequence current component, rate of change of positive-sequence current component
  - ...
  - Might work well under specific operation conditions (e.g., solar irradiance, IBR operation mode).
- Data-driven-based approach has big potential:
  - Fast detection
  - Needs reliable and large data set for training
  - Need to improve the classification accuracy.





Thank you!