



U.S. DEPARTMENT OF  
**ENERGY** | Energy Efficiency &  
Renewable Energy  
BIOENERGY TECHNOLOGIES OFFICE



## Task 3.1: Research and Development Guiding Technoeconomic Analysis and Life-Cycle Assessment

### BETO 2023 Project Peer Review

Performance-Advantaged Bioproducts and Bioprocessing Separations

April 6, 2023

This presentation does not contain any proprietary, confidential, or otherwise restricted information

NREL/PR-5100-85828

**National Renewable Energy  
Laboratory:** Eric Tan, Jacob Dempsey,  
Hakan Olcay

**Pacific Northwest National  
Laboratory:** Jian Liu

**Argonne National Laboratory:** Pahola  
Thathiana Benavides



# Project Overview

- **Context**

- Technologies under development aim to increase yields of desired end products, reduce overall raw material costs, and/or develop more energy-efficient strategies for product recovery.
- Technoeconomic analysis (TEA) and life-cycle assessments (LCA) help assure that economic and sustainability predictions of the technologies are unbiased and compelling and provide guidance to experimentalists on areas that need focus.

- **Project goals**

- Building on previous work, continue to use the integrated TEA and LCA to evaluate and guide technologies under development and target challenges relevant to the industry and the Bioenergy Technologies Office (BETO) priority pathways.
- Provide credible, unbiased assessments for each technology under development, with ongoing assessments to guide experimental teams.
- Support journal publications highlighting key findings.

# Approach: Integrated Analyses

## Assess technical, economic, and environmental feasibility of bioproduct/biofuel processes:

- Conduct detailed process analysis with rigorous mass and energy balances.
- Identify data needs and further research and development needs to improve overall cost and efficiency.
- Assess environmental impacts [greenhouse gas (GHG) emissions, fossil fuel, water consumption].
- Approach is consistent with other BETO-sponsored analyses.

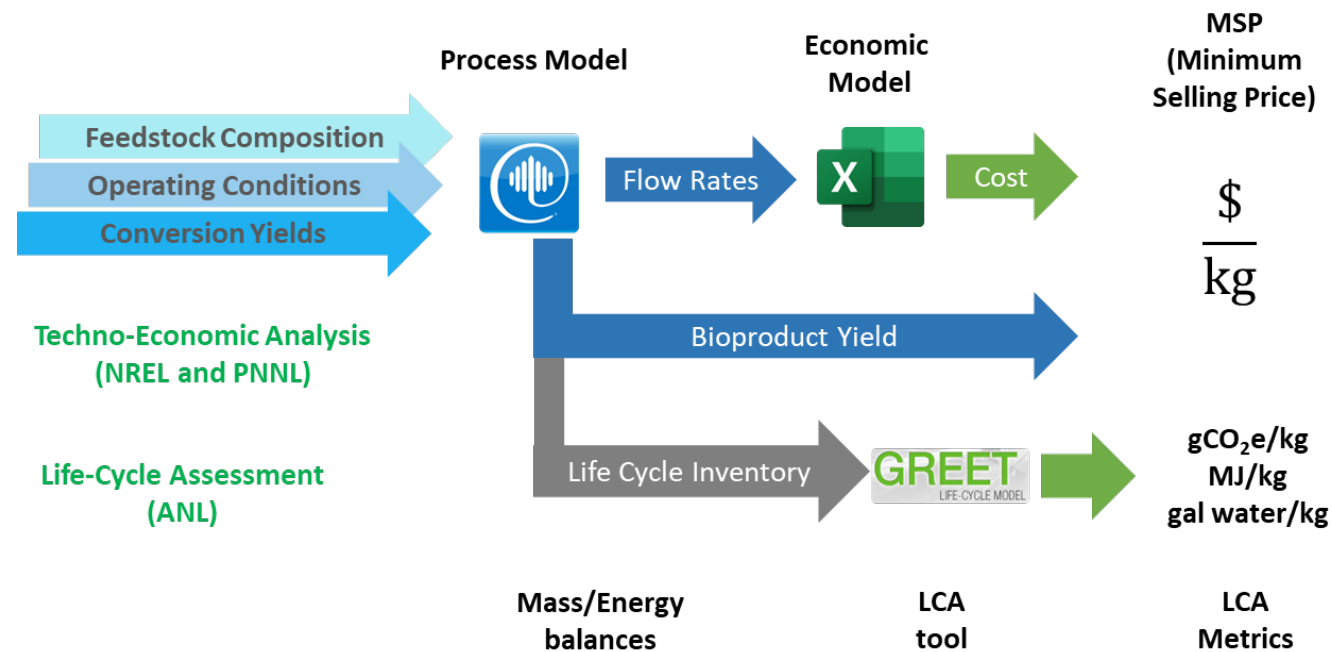

# Approach: Techno-Economic Analysis

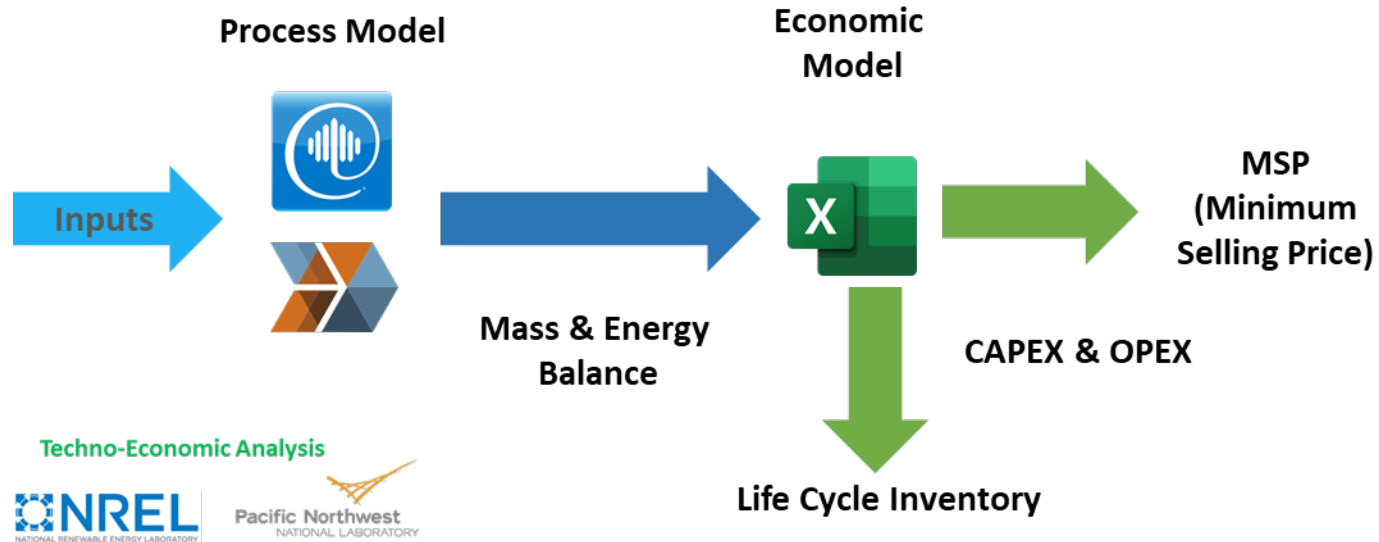

- Capital expenditures (CAPEX) and operational expenses (OPEX) were estimated using multiple sources (i.e., Aspen Process Economic Analyzer, vendor quotes, internal databases, literature data, and discussion with researchers).
- The minimum selling price (MSP) was estimated using the discounted cash flow method with determined economic assumptions.
- A life-cycle inventory table (e.g., energy and material consumption, waste discharge, product and co-product productivity, utilities) was generated for the LCA team.

# Approach: Life-Cycle Assessment

## System boundary

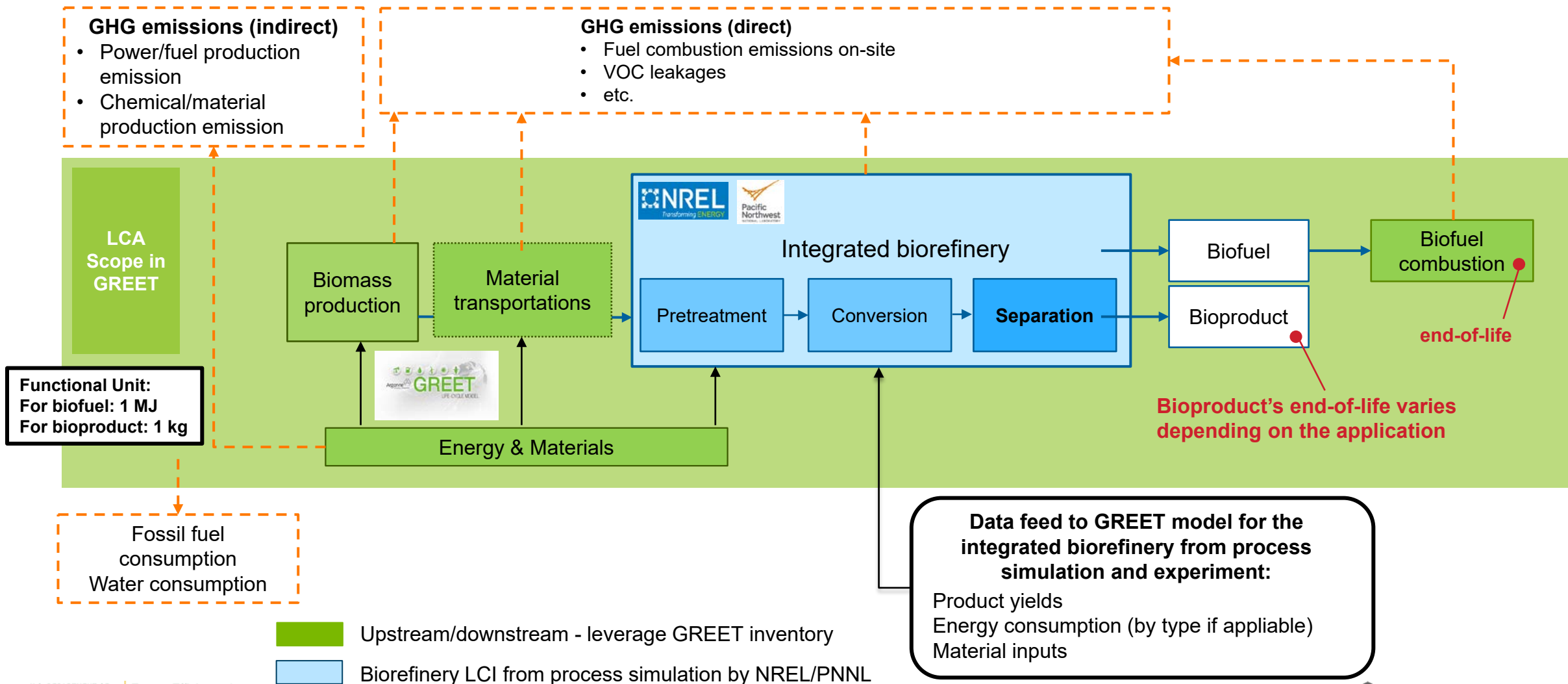



# Approach: Analysis-Related Challenges

- In some cases, no existing state of technology (SOT) or target case for comparison
  - Establish base cases from literature and patents.
- Data (experiment data, thermodynamic property) availability and quality
  - Inform and guide data collection from experimental teams
  - Consolidate data and thermodynamic property.
- Rigorous modeling for large-scale separation process
  - Leverage BETO's existing models and unit operation information.
- Uncertainty of capital cost for new and novel technologies
  - Vendor interaction.
- Evaluate technology under development
  - Work closely with experiment team and receive regular updates.

# Approach: Management and Diversity, Equity, and Inclusion

- Track progress with monthly consortium meetings.
- Hold biweekly analysis meetings with TEA/LCA team (NREL, PNNL, Argonne).
- Organize inter-laboratory meetings to coordinate milestones and deliverables.
- Support Go/No-Go decisions and milestones.
- Hold biannual meeting with Industrial Advisory Board for progress updates and feedback.
- Collaborate with other BETO projects and industry partners (e.g., Agile BioFoundry).
- Participated in outreach activities and support student internships (FY22).
- Will participate in Bioenergy to Bridge Program (FY23).

# Approach: Go/No-Go Decision and Milestone

|  |   |  |   |
|--|---|--|---|
| D.1 [NREL, PNNL, LANL, ANL]: TEA and LCA on 2,3-Butanediol (BDO) separation (Go/No-Go) | Perform TEA and LCA on three BDO separation approaches: (1) solvent extraction, (2) reactive adsorption to produce dioxolane, (3) extension of approach (2) to convert dioxolane back into BDO. | (I) Achieve >90% separation efficiency; (II) Save at least 1/3 of energy compared to vacuum distillation; (III) Quantify life-cycle GHG emissions and fossil energy usage. | 6/30/2022<br>  |
| D.2 [PNNL, NREL, LANL]: Annual Milestone (Regular)                                     | Complete the revised separations challenge stream analysis, identifying the top challenge streams based on the economic potential of effective product separation.                              | Identify the top challenge streams and submitted a publication.  | 9/30/2022<br> |



# Progress and Outcomes: Case Study 2,3-Butanediol (BDO) Separations

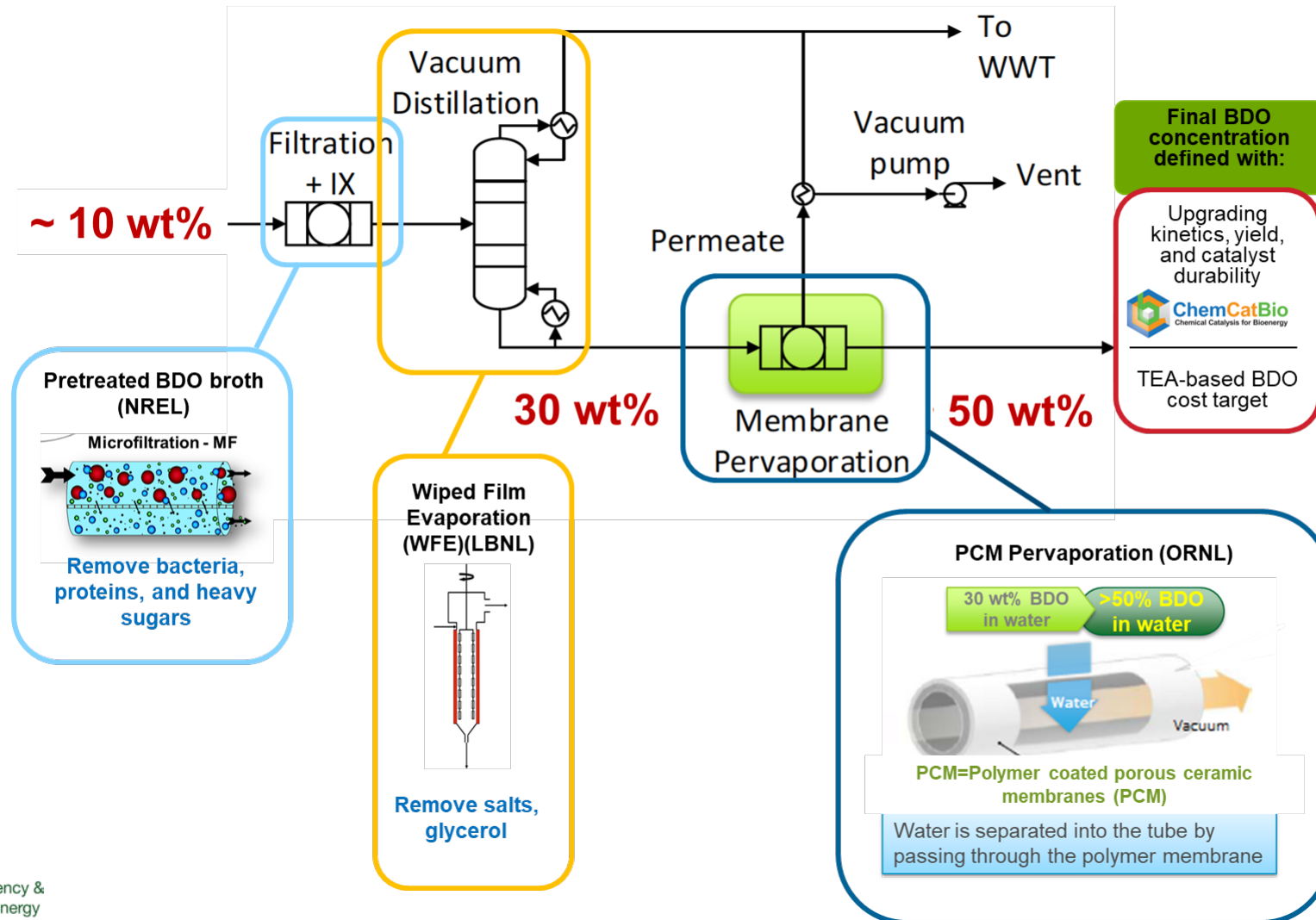

# Progress and Outcomes: BDO Separations Peer Review Comment 2021

- Whether pervaporation is energy efficient compared to the SOT?
  - Multiple stages of membrane pervaporation are needed.
  - Heat exchange is needed in between each stage to reheat the stream.

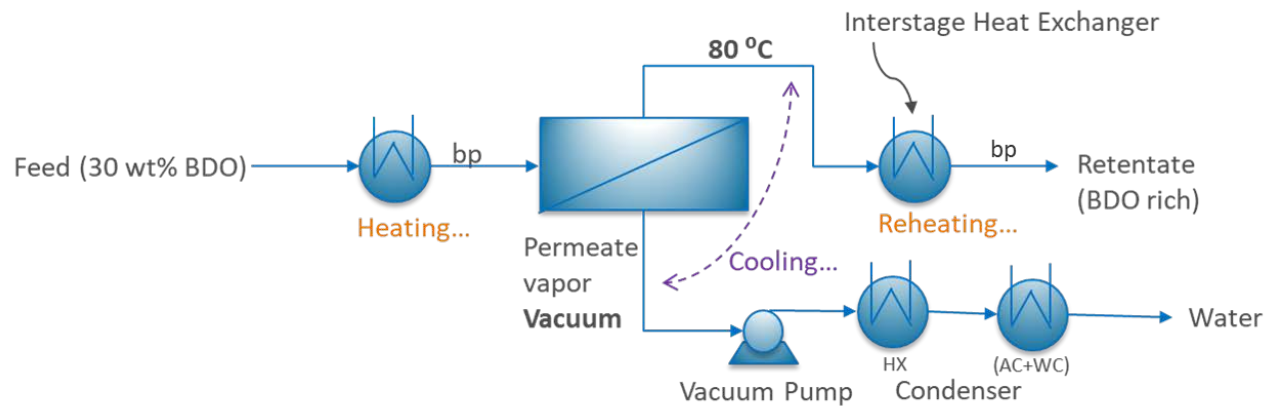

- The use of pervaporation on dilute BDO concentration stream did not show superior energy/cost savings compared to the SOT evaporation/distillation.

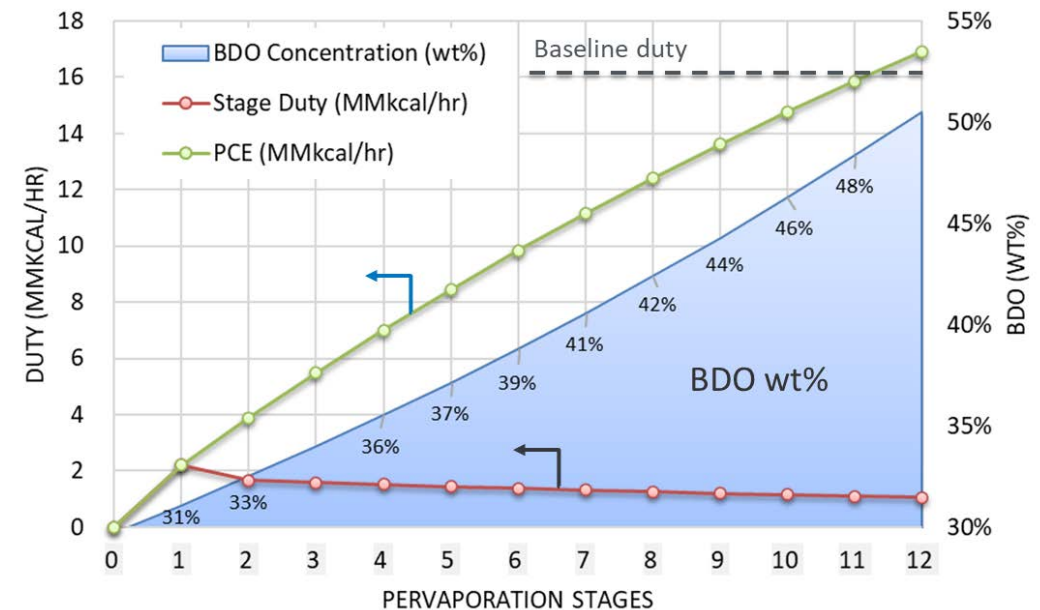

# Progress and Outcomes: BDO Separations Alternative Approaches 2022

## Baseline – Cascade Vacuum Distillation

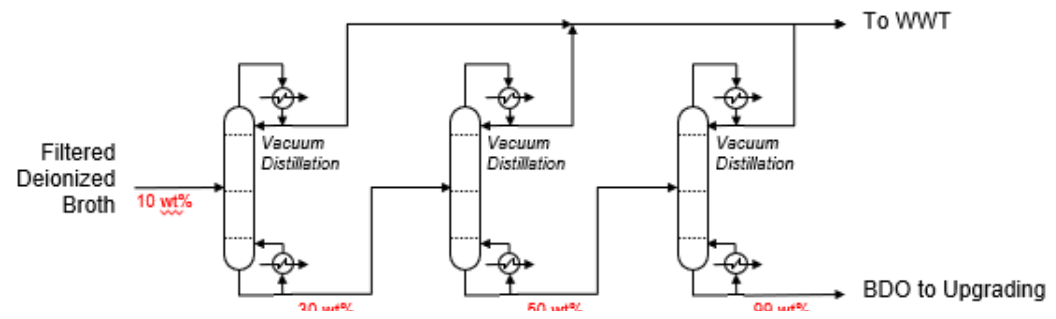

## Approach 1 – Liquid/Liquid Extraction

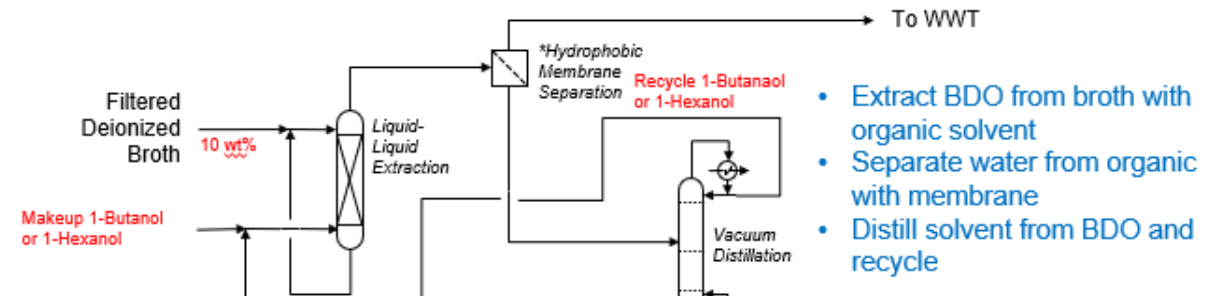

## Approach 2 – Conversion to Dioxolane

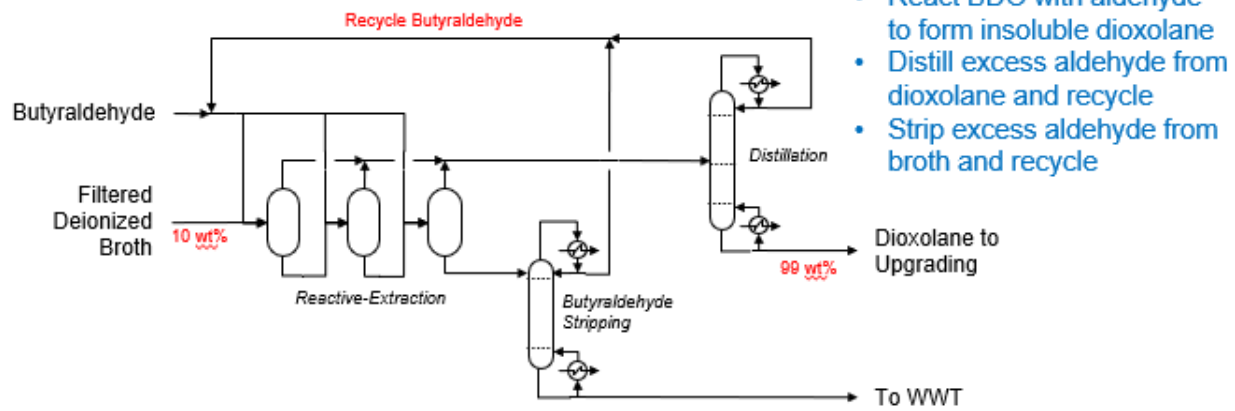

## Approach 3 – Reactive Extraction

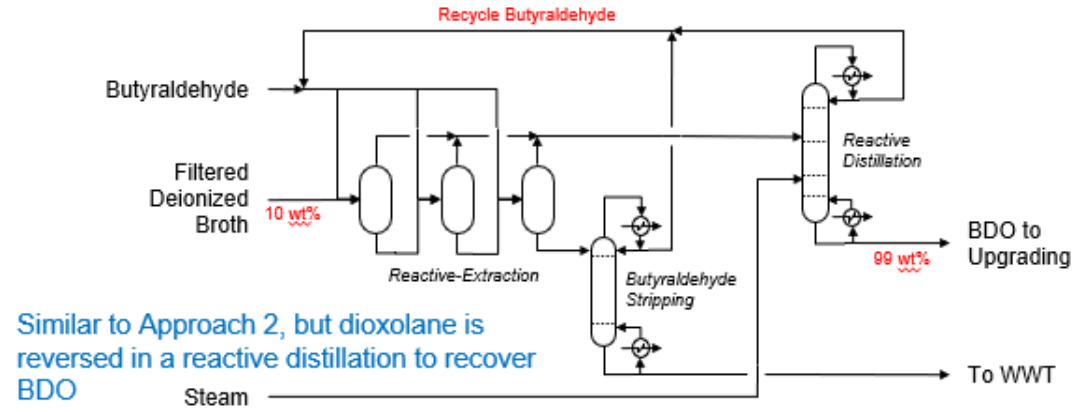

*Established alternative approaches that combine TEA and LCA assessments.*

# Progress and Outcomes: Go/No-Go Highlights

## TEA

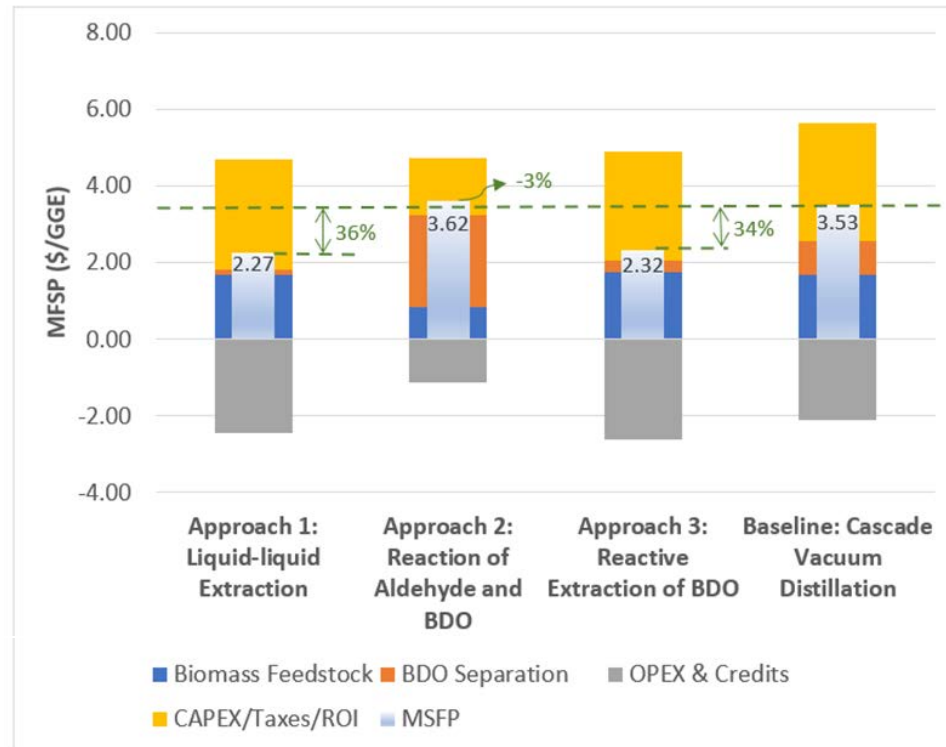

## LCA

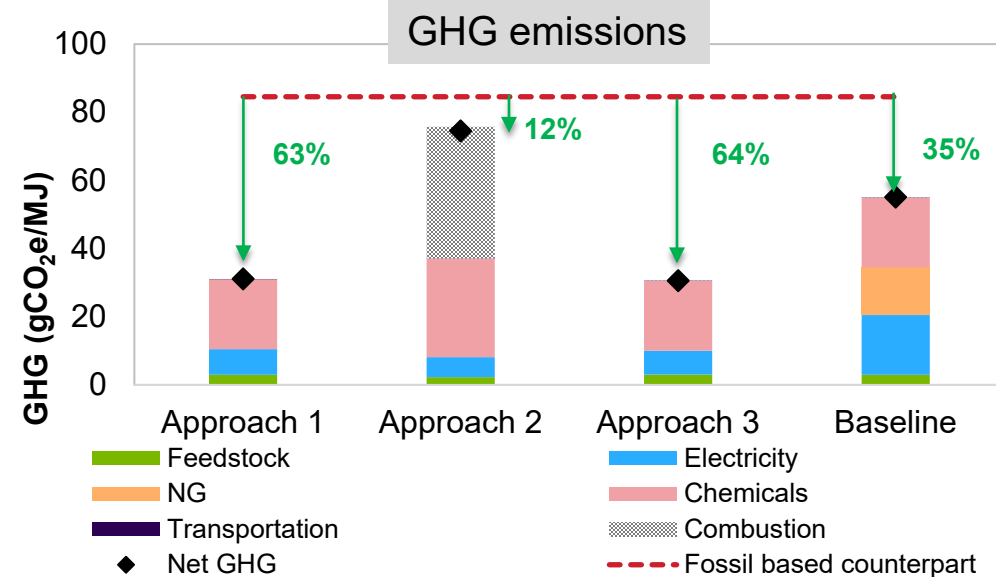

- Achieved recovery of more than 90% of the BDO from fermentation broth with high purity.
- Achieved heating duty less than 30% of the lower heating value (LHV) of the BDO.
- Life-cycle GHG emissions reduction in all four approaches compared to fossil-based jet and baseline.

# Progress and Outcomes: Separation Challenge Stream Analysis Update

## Hydrothermal Liquefaction

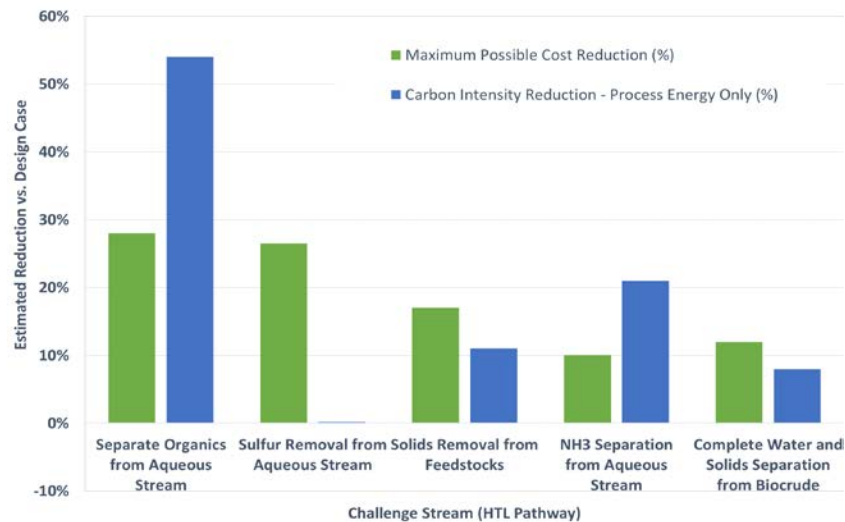

## Biochemical Conversion

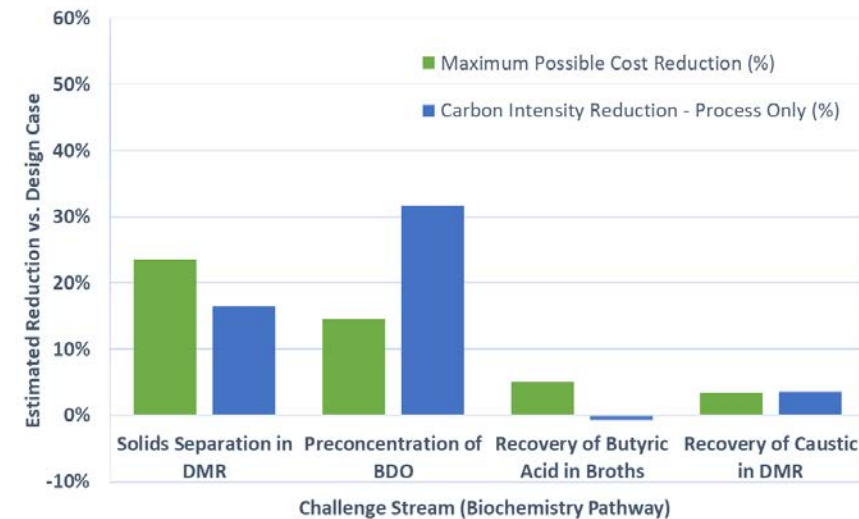

- Baseline TEA models and “ideal” separators were used to assess best-case impact of identified separations challenges.
- Critical opportunity areas were found where gains were identified: reductions or elimination of downstream equipment, new coproducts, raw material savings, and certain energy savings.
- Completion of challenge stream assessment work met criteria for FY22 4<sup>th</sup> Quarter annual milestone and analysis guided development of multi-year R&D plan.

# Impact

- **Developed continuous process models** to predict stream properties for conventional filtration and tangential flow filtration processes. **Elucidated cost and performance drivers** for alkaline pretreated liquor fractionation. (Task B1)
- Identified **key cost drivers** and demonstrated a **more than 50% reduction in GHG emissions** by integrating capacitive deionization. (Task B2)
- **Modeled three alternative separations for BDO** and **helped drive exploration** of extraction approach to minimize residual water removal. (Task B3)

## Task B3

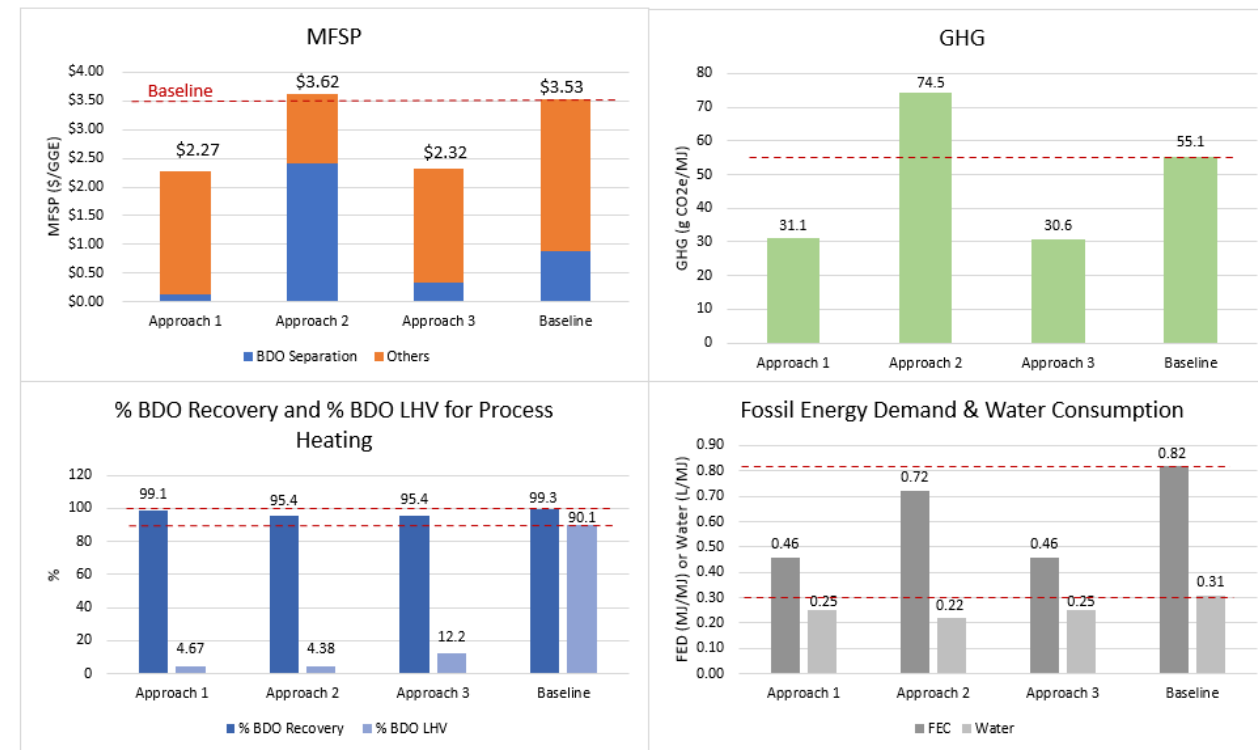

# Impact

- Demonstrated **5% energy use for solvent recovery** in the Cell Utilized Partition model and **more than 2X product collection** for counter-current chromatography compared to the simulated moving bed. (Task C1)
- Demonstrated best case **15% saving in energy consumption** and **28% in GHG emissions reduction**. (Task C2)
- **Quantified maximum potential impact** of separation on MFSP and carbon intensity, guiding multi-year R&D plan. (Task D2)
- **Published results** on carboxylic acids recovery and challenge stream analysis with demonstrated economic viability and **sustainability improvements** over the base case, boosting the competitive advantage of bioeconomy.

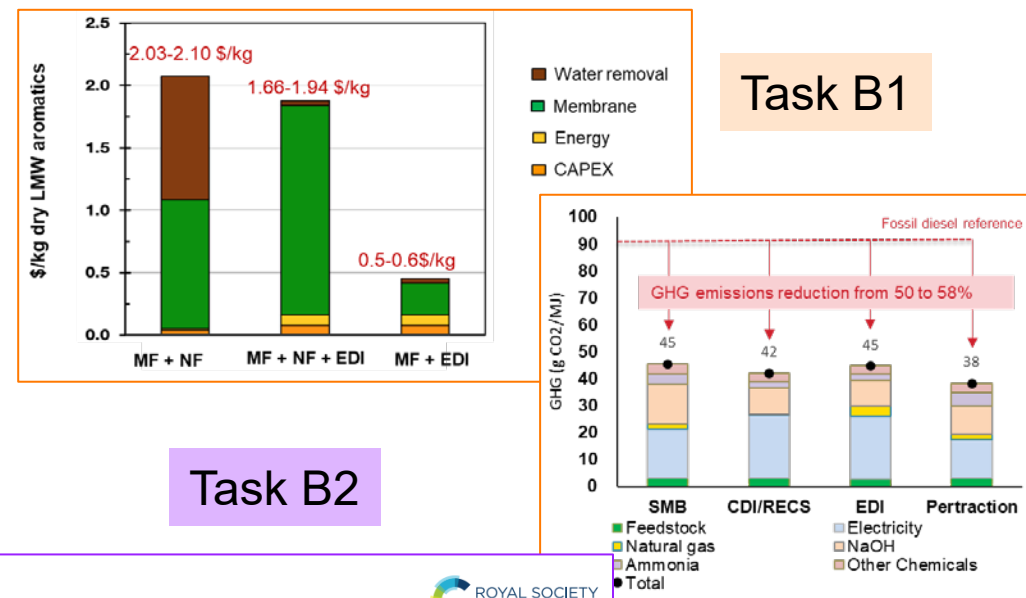

**Green Chemistry**

ROYAL SOCIETY OF CHEMISTRY

PAPER

View Article Online  
View Journal | View Issue

Check for updates

**Energy and techno-economic analysis of bio-based carboxylic acid recovery by adsorption†**

Patrick O. Saboe, Lorenz P. Manker,† Hanna R. Monroe, William E. Michener, Stefan Haugen, Eric C. D. Tan, Ryan L. Prestangen, Gregg T. Beckham, and Eric M. Karp\*

Recent works have established bio-based carboxylic acids as adaptable precursors to renewable biofuels and chemicals. However, the separation of carboxylic acids is a major energy and cost driver, accounting for 20–40% of the entire processing cost. Improved downstream separation technologies that reduce operating costs compared to conventional approaches are needed, particularly to enable bio-based commodity fuels and chemicals. Here, we combine techno-economic analysis (TEA) and an energy and

Received 22nd March 2022  
Accepted 2nd June 2022  
DOI: 10.1039/d1gc01111g

frontiers | Frontiers in Sustainability

Original Research  
Published: 23 November 2022  
doi: 10.3389/fsts.2022.109640

**Task D2**

... methodology for assessing the maximum potential impact of separations opportunities in industrial processes

Jian Liu<sup>1\*</sup>, Jacob W. Dempsey<sup>2</sup>, Shuyun Li<sup>1</sup>, Yuan Jiang<sup>1</sup>, Lestley J. Snowden-Swan<sup>1</sup>, William L. Kubick<sup>3</sup>, Eric C. D. Tan<sup>1\*</sup> and Charles J. Freeman<sup>1\*</sup>

<sup>1</sup>Pacific Northwest National Laboratory, Richland, WA, United States, <sup>2</sup>National Renewable Energy Laboratory, Golden, CO, United States, <sup>3</sup>Los Alamos National Laboratory, Los Alamos, NM, United States

OPEN ACCESS

EDITED BY  
Bing Shen How,  
Saitama University of Technology,  
Saitama Campus, Malaysia

REVIEWED BY  
Jaya Prasanth Rajak,  
Saitama University of Technology,  
Saitama Campus, Malaysia  
Shan Jing Chen,  
Saitama University of Technology,  
Saitama Campus, Malaysia

\*CORRESPONDENCE  
Jian Liu  
jian.liu@pnl.gov  
Eric C. D. Tan  
eric.tan@pnl.gov

**Cell Reports Physical Science**

Article

Process intensification for the biological production of the fuel precursor butyric acid from biomass

**Hybrid Extraction-Distillation (HED)-In Situ Product Recovery (ISPR) Process**

Lipidolactonic sugars

Fermentation (Cobacterium tyrobutylicum)

Fuel Precursor (Butyric Acid)

Highlights  
Butyric acid is a promising intermediate precursor for diesel and jet fuel.  
An integrated, energy-efficient process for butyric acid production is developed.  
Rural biorefineries in integrated with hybrid extraction-distillation (HED-ISPR) processes.  
Techno-economic and life cycle assessment favor HED-ISPR processes.

Submitted to present the development of a fully integrated process to produce a fuel precursor, butyric acid, from lignocellulosic sugars and show that the selling price of butyric acid is significantly lower than that of petroleum. The study includes intensive fermentation, intensive development, separation science, and economic and environmental assessments.

Divina Subachia, Patrick O. Saboe, Robert S. Nelson, Gregg T. Beckham, Eric M. Karp, Jeffrey G. Linger  
divina.subachia@pnl.gov (DS), robert.nelson@pnl.gov (RSN), jeffrey.linger@pnl.gov (JGL)

# Quad Chart Overview

## Timeline

- Project start date: October 2022
- Project end date: September 2025

|                      | FY22 Costed                        | Total Award |
|----------------------|------------------------------------|-------------|
| DOE Funding          | (10/01/2021 – 9/30/2022)<br>\$825K | \$1.74M     |
| Project Cost Share * | N/A                                | N/A         |

TRL at Project Start: N/A  
TRL at Project End: N/A

## Project Goal

The integrated TEA and LCA will guide research teams to develop efficient methods and technology by evaluating economic and environmental impacts relevant to industry and BETO's priority pathways.

## End of Project Milestone

The overall end of the project milestone is to demonstrate the consortium's value to BETO and the biofuel and bioproduct communities through documentation of technical advances, influence on process economics, and potential industrial applications of consortium technologies.

## Project Partners

- N/A



# Summary

|                           |   |
|---------------------------|---|
| <b>Overview</b>           | <p>TEA and LCA evaluate and guide separation technologies under development by the consortium and target challenges relevant to industry and BETO's priority pathways.</p>  |
| <b>Technical approach</b> | <ul style="list-style-type: none"> <li>• Detailed process analysis with rigorous mass and energy balances.</li> <li>• Worked closely with R&amp;D team to obtain data needed to effectively model proposed separations technology.</li> <li>• Informed experimental team and provided guidance to further improve economic and environmental metrics.</li> <li>• Participated in regular calls with experimentalists and analysts as well as coordinated with other BETO consortia.</li> <li>• Developed models to assess environmental and economic impacts of proposed technology at a refinery level.</li> </ul> |
| <b>Impact</b>             | <ul style="list-style-type: none"> <li>• Identified R&amp;D needs to enable improved performance of separation strategies.</li> </ul>   |
| <b>Progress</b>           | <ul style="list-style-type: none"> <li>• Identified favorable performance (both TEA and LCA) cases warranted for further R&amp;D.</li> </ul>  |
| <b>Future work</b>        | <ul style="list-style-type: none"> <li>• Continue to support TEA/LCA of new separation consortium strategies.</li> <li>• Document technical advances from each consortium team and their influence on process economics.</li> </ul>   |

# Acknowledgements

U.S. DEPARTMENT OF  
**ENERGY** | Energy Efficiency &  
Renewable Energy

BIOENERGY TECHNOLOGIES OFFICE

- Gayle Bentley



**BERKELEY LAB**

- Ning Sun  
- Eric Sundstrom  
- Dupeng Liu



- Ramesh Bhave  
- Syed Islam



- YuPo Lin  
- Lauren Valentino  
- Phil Laible  
- Meltem Urgun-Demirtas



- Gregg Beckham  
- Patrick Saboe  
- Hoon Choi  
- Ryan Davis  
- Bruno Klein  
- Others



- Bill Kubic



- Charlie Freeman  
- Mike Thorson  
- Lesley Snowden-Swan  
- Shuyun Li  
- Yuan Jiang  
- Aye Meyer

**Thank you!**

# Publications, Patents, Presentations, Awards, and Commercialization

1. “Energy and Techno-economic Analysis of Bio-based Carboxylic Acid Recovery by Adsorption,” *Green Chemistry*, 23, 4386-4402 (2021).
2. “The cell utilized partitioning model... for optimizing counter-current chromatography...,” *Separation and Purification Technology*, 285:15 (2021).
3. “Process Intensification for the Biological Production of the Fuel Precursor Butyric Acid from Biomass,” *Cell Reports Physical Science*, 2(10), 100587 (2021).
4. “Separation of Bio-Based Glucaric Acid via Antisolvent Crystallization and Azeotropic Drying,” *Green Chemistry*, 24, 1350-1361 (2022).
5. “Fractionation of the Lignin Streams Using Tangential Flow Filtration,” *Industrial & Engineering Chemistry Research*, 61, 4407-4417 (2022).
6. “Recovery of Low Molecular Weight Compounds from Alkaline Pretreated Liquor via Membrane Separations,” *Green Chemistry*, 24, 3152-3166 (2022).
7. “Methodology for Assessing the Maximum Potential Impact of Separations Opportunities in Industrial Processes,” *Frontiers in Sustainability*, 3:1056580 (2022).

# Additional Slides

# Responses to Previous Reviewers' Comments

## Peer Review Comment from 2021

- Whether pervaporation is energy efficient compared to SOT?
  - Multiple stages of membrane pervaporation are needed
  - Heat exchange is needed in between each stage to reheat the stream

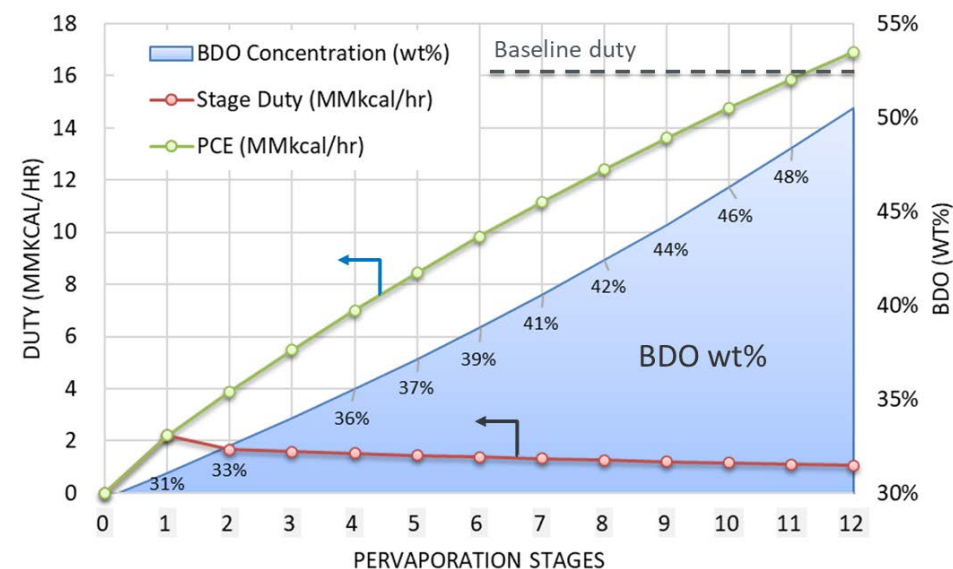
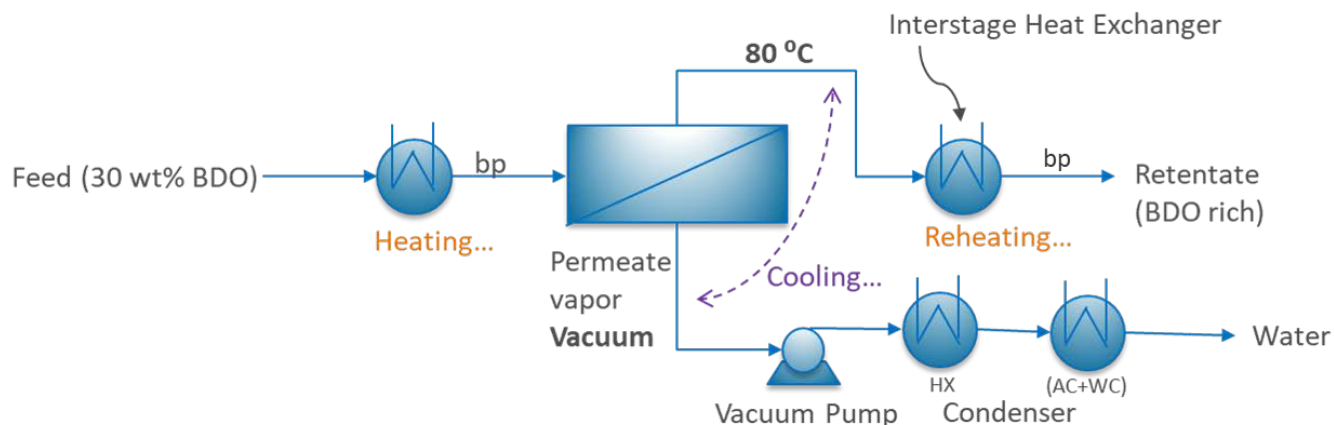

- The use of pervaporation on dilute BDO concentration stream did not show superior energy/cost savings compared to the SOT evaporation/distillation.

# Progress and Outcomes BDO Separations: TEA results

- ✓ Achieved recovery of more than 90% of the BDO from the fermentation broth with high purity
- ✓ Achieved heating duty less than 30% of the lower heating value (LHV) of the BDO

| Parameters                   | Approach 1:<br>Liquid-liquid<br>Extraction | Approach 2:<br>Reaction of<br>Aldehyde<br>and BDO | Approach 3:<br>Reactive<br>Extraction of<br>BDO | Baseline:<br>Cascade<br>Vacuum<br>Distillation |
|------------------------------|--|---|---|--|
| BDO Recovery (%)             | 99.1%                                      | 95.4% <sup>a</sup>                                | 95.4%   | 99.3%  |
| BDO purity (wt.%)            | > 99%                                      | n.a. <sup>b</sup>                                 | > 99%   | > 99%  |
| Heating duty (kJ/kg)         | 1,271                                      | 1,192 <sup>c</sup>                                | 3,317   | 24,499   |
| % of LHV of BDO <sup>d</sup> | 4.67%                                      | 4.38%   | 12.2%   | 90.1%  |

<sup>a</sup> % conversion BDO to into 2-propyl-4,5-dimethyl-1,3-dioxolane

<sup>b</sup> Not applicable

<sup>c</sup> per kg BDO in dioxolane

<sup>d</sup> 2,3-BDO lower heating value (LHV) 27.2 MJ/kg<sup>2</sup>

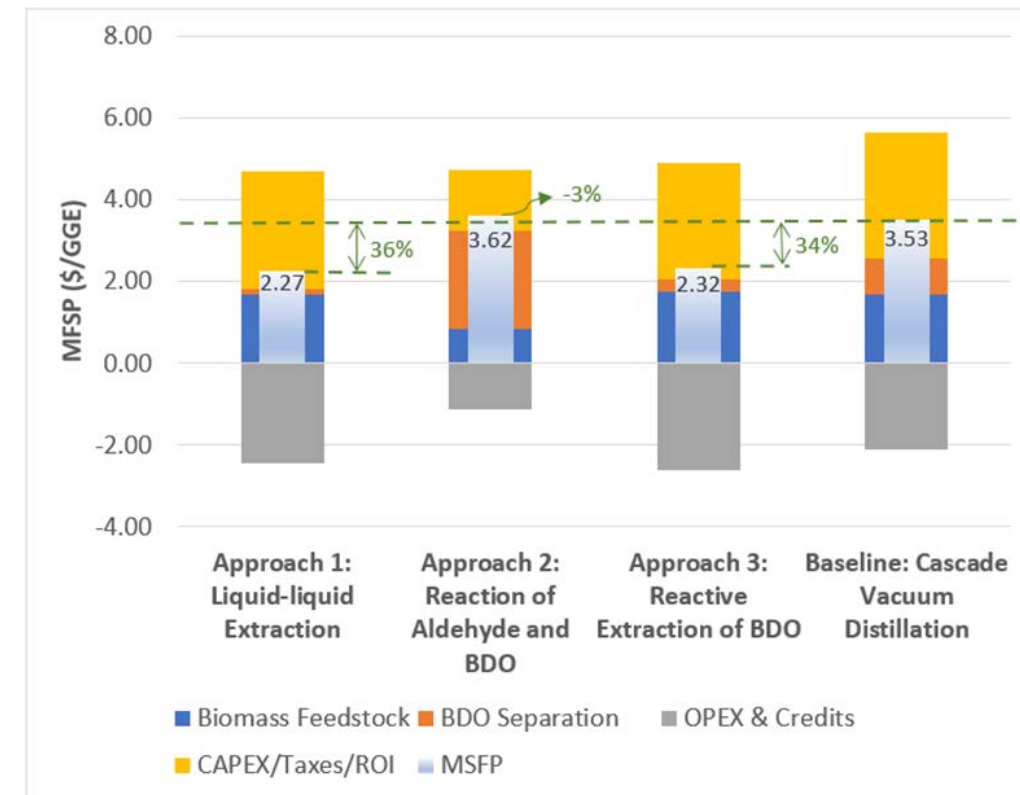

# Progress and Outcomes BDO Separations: LCA results

## ✓ Life-cycle GHG emissions reduction in all four approaches compared to fossil-based jet and baseline.

- Lowest emissions achieved from approaches 1 and 3 (60% lower than fossil jet and 40% lower than the baseline):
  - Natural gas (NG) demand was eliminated while grid electricity use is 60% lower
  - Chemical inputs were similar.
- Approach 2 resulted in 35% higher GHG emissions than the baseline case:
  - Electricity was reduced by 67% while no NG demand
  - But butanal was carbon-intensive to produce
  - Combustion emissions were higher since fossil carbon in butanal represents 54% of carbon in final fuel product.
- Fossil energy consumption (FEC) results were consistent with GHG emissions results:
  - Compared to the baseline case, approaches 1 and 3 showed a significant reduction in fossil energy use.
- Water consumption (WC) was higher than fossil jet and baseline cases: Mainly from embedded chemical inputs and process water.

