



Introduction to Grid Forming Inverters

— a Key to Transforming our Power Grid

Ben Kroposki

Director – Power Systems Engineering Center

National Renewable Energy Laboratory

UNIFI Consortium Organizational Director

June 2024

Why do we need Grid-forming (GFM) Inverters in the Bulk Power System?

U.S. electricity generation from renewable energy sources, 1950-2022

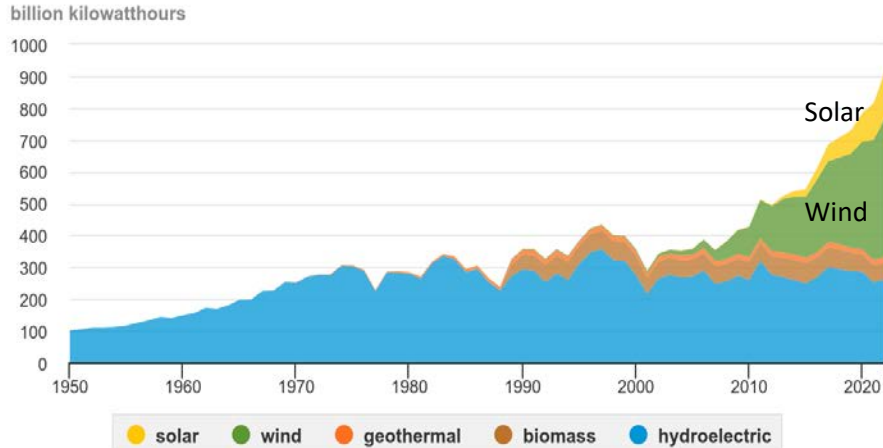

Data source: U.S. Energy Information Administration, *Monthly Energy Review* and *Electric Power Monthly*, February 2023, preliminary data for 2022

Note: Includes generation from power plants with at least 1 megawatt electric generation capacity. Hydroelectric is conventional hydropower.



There is a rapid increase in the amount of inverter-based resources (IBRs) on the grid from Solar PV, Wind, and Batteries.



Photo: NREL

All of these technologies are Inverter-based Resources (IBRs).



Photo: NREL

Solar, Wind, and Batteries is expected to make up 94% of new U.S. electric-generating capacity in 2024

U.S. planned utility-scale electric-generating capacity additions (2024) gigawatts (GW)

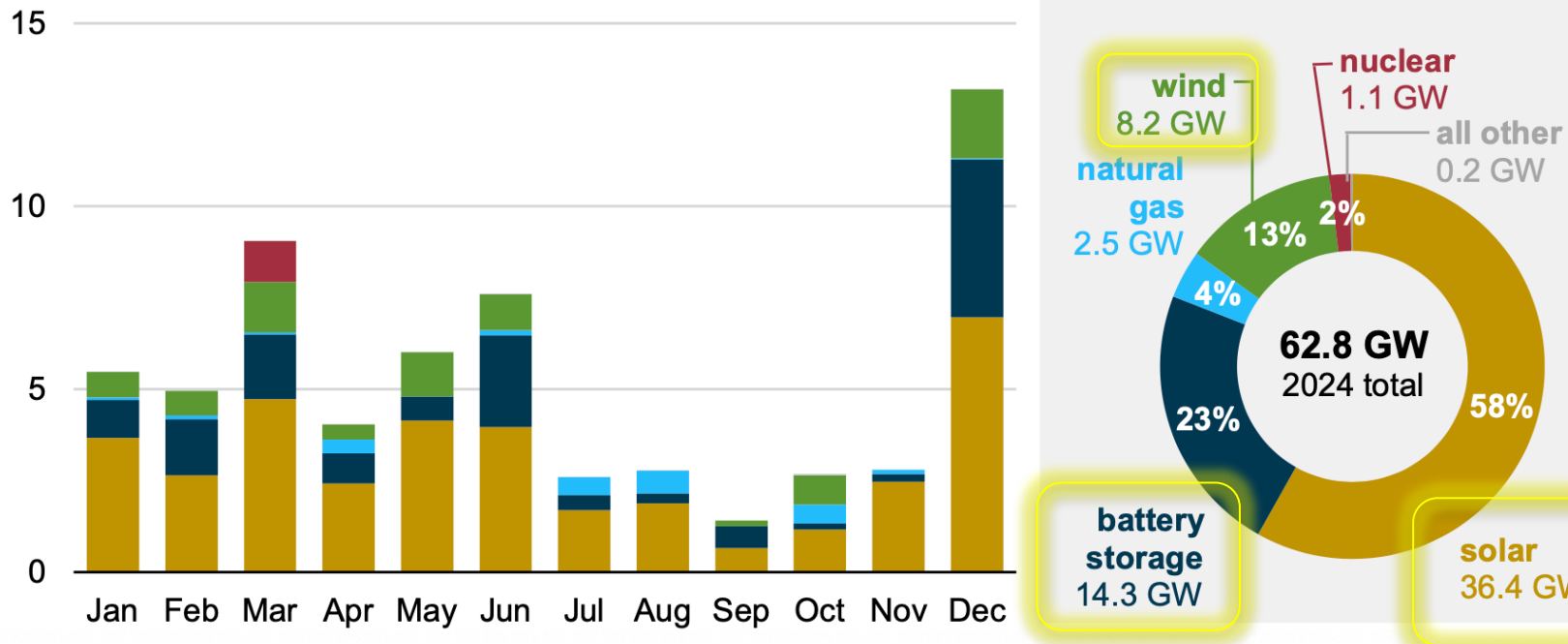

Data source: U.S. Energy Information Administration, *Preliminary Monthly Electric Generator Inventory*, December 2023

What is driving the rapid deployment of utility-scale wind and solar?

They are the most cost-competitive forms of new electricity

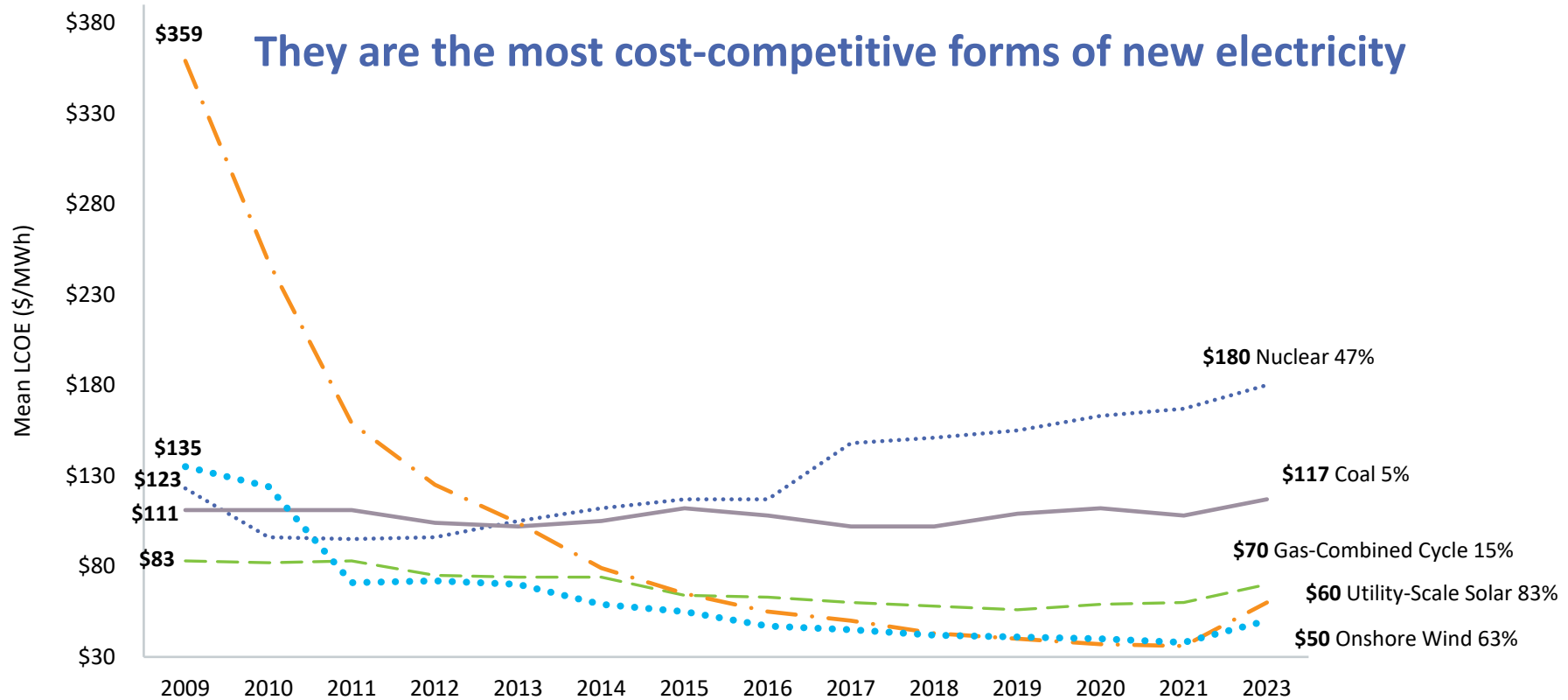

Source: Lazard's Levelized Cost of Energy Analysis, 2023

Difference between Synchronous Generators and Inverter-based Resources (IBRs)

Conventional power plants use large rotating synchronous generators to produce electricity

Coal, Natural Gas, Nuclear, and Hydro

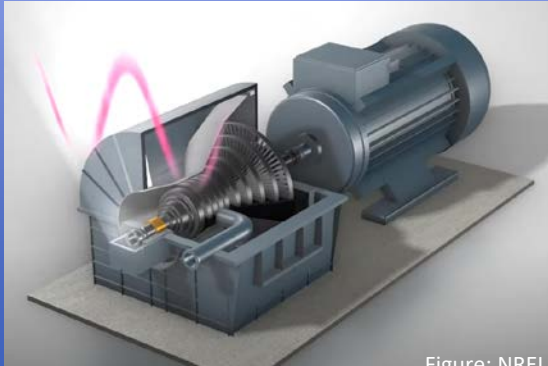

Figure: NREL

[Learn more about generator inertia](#)

Variable Renewables and Batteries use inverters to produce electricity

Wind, Solar PV, and Batteries

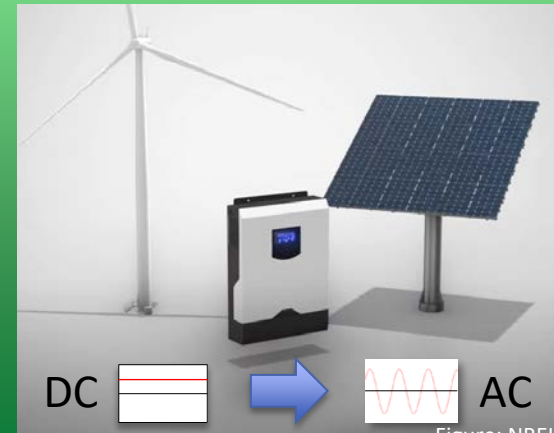

Figure: NREL

[Learn more about inverters](#)

Types of Inverters

Grid Following (GFL)

vs.

Grid Forming (GFM)

Inverter Output

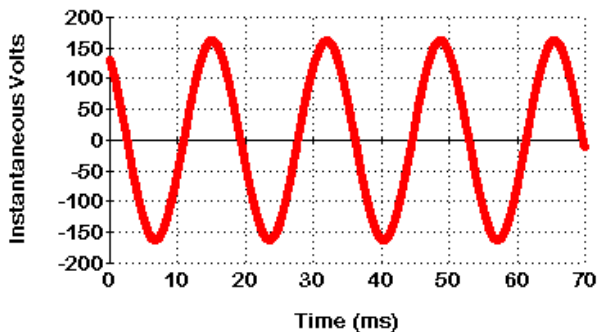

Source: Lin, Yashen, Joseph H. Eto, Brian B. Johnson, Jack D. Flicker, Robert H. Lasseter, Hugo N. Villegas Pico, Gab-Su Seo, Brian J. Pierre, and Abraham Ellis. 2020. **Research Roadmap on Grid-Forming Inverters.** Golden, CO: National Renewable Energy Laboratory. NREL/TP-5D00-73476. <https://www.nrel.gov/docs/fy21osti/73476.pdf>.



- GFL IBR controls output **Current**
- Is dependent on another source to synchronize to



- GFM IBR controls output **Voltage**
- Can make its own voltage waveform



Grid Forming 101 - Quick Questions

GFL vs. GFM – is it just software or is there a hardware difference?

For the most part, the control algorithms are just software changes. Some current inverters can already be programmed to switch modes on the fly. Some capabilities (e.g. blackstart) may require hardware changes.

How easy is it to retrofit older inverters?

It is usually difficult to retrofit older GFL with new control software.

How much GFM do I need in the system?

Each system is different and response to abnormal conditions vary, but it is good to have at least 25-30% grid forming resources in the system. Best place to put GFM is in the weakest parts of the grid. (See references)

Do I need energy storage?

GFM paired with energy storage offers the full capabilities of GFM response.

What we know today...

Operating Power Grids with High Levels of IBR

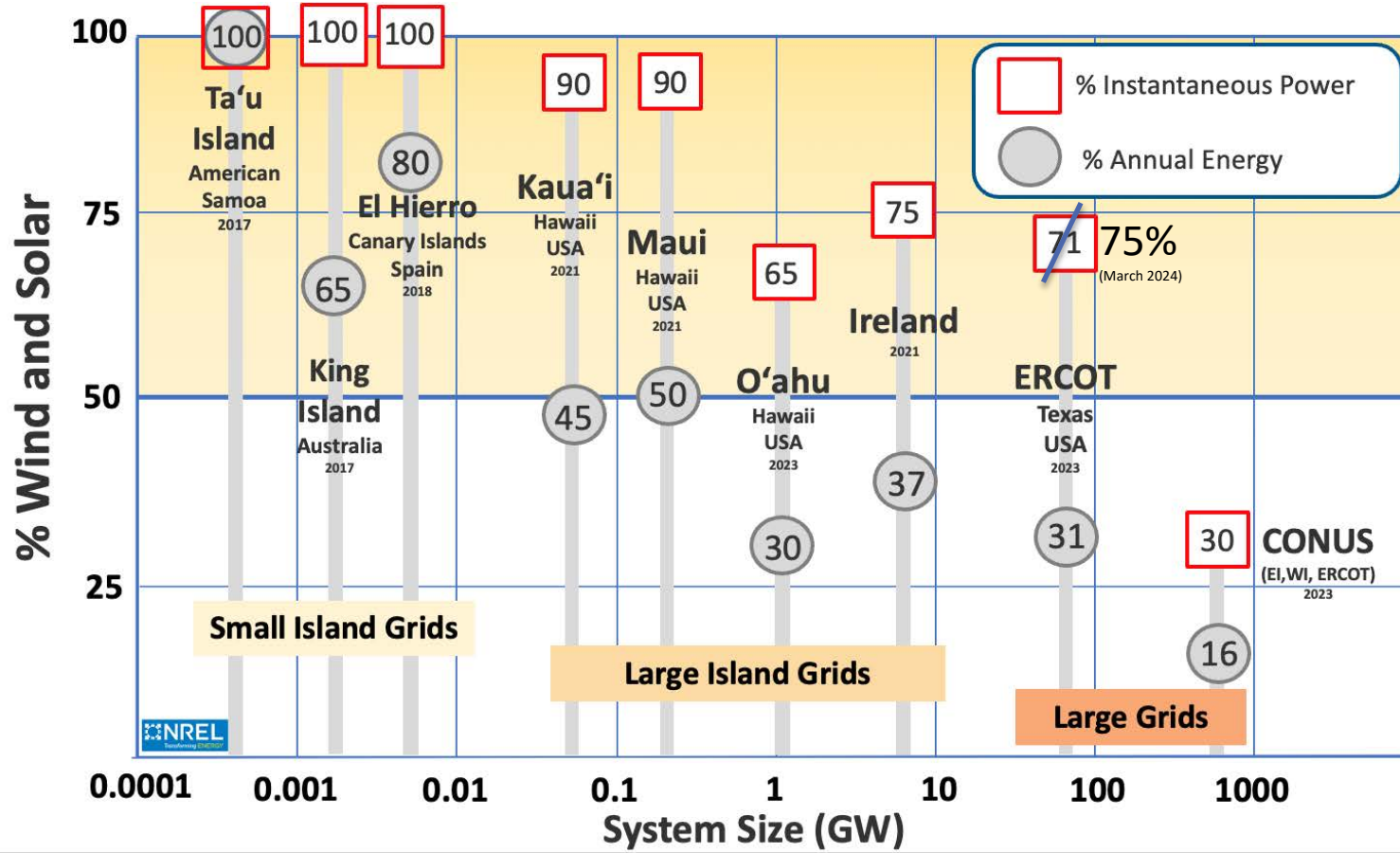

Ultra-high levels of IBR are enabled by:

- 1) Responsive IBR
- 2) GFM
- 3) Energy Storage

Why GFM? - Let's take a closer look at Grid Stability



microWECC model

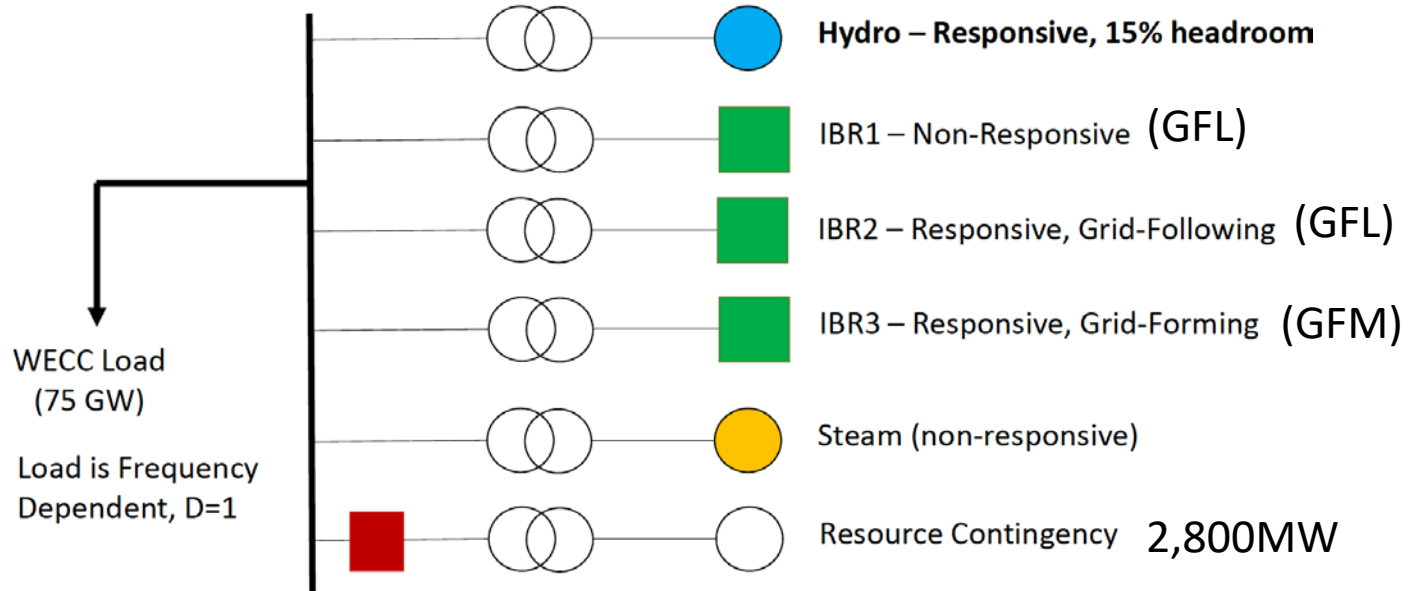

Source: Frequency Response in High IBR Scenario Illustration Studies, WECC Modeling and Validation Subcommittee September 2022, D. Kosterev, M. Ayala Zelaya, E. Mitchell-Colgan, BPA Transmission Planning

Why GFM? — Here is the response with just Grid-following (GFL)

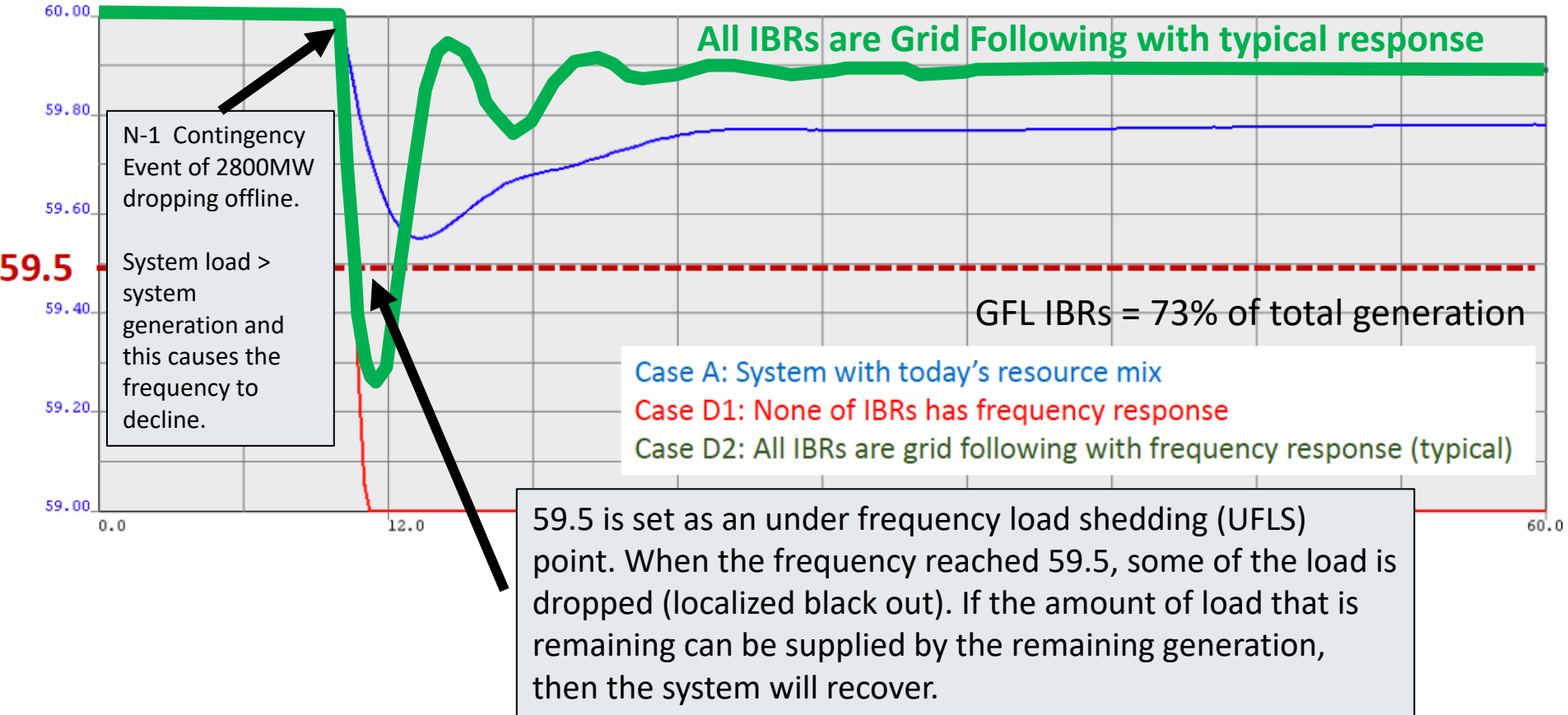

Why GFM? – Switching to Grid-forming (GFM)

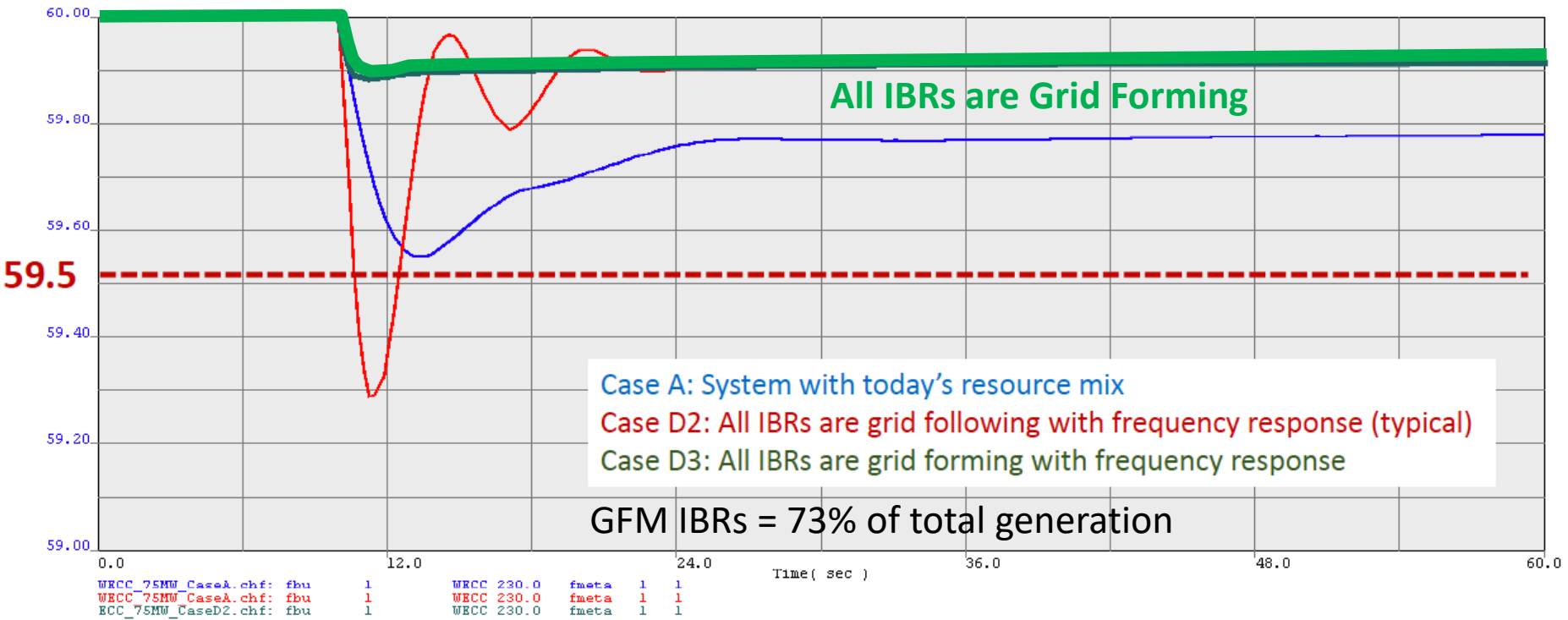

IBR Fast frequency response from grid-forming inverters can be effective in maintaining system frequency (inverter-level, droop control, headroom)

GFM Value Proposition

- Essential Reliability Services (improved stability)
- Black-start Capabilities
- Improved Power Grid Reliability and Resilience

Value Proposition for Grid-Forming (GFM) Inverters

What's Inside?
An overview of value that can be unlocked with the choice of GFM inverter technology in renewable integration projects across scales.

Topics covered

- Grid-forming inverters overview
- Essential reliability service markets
- Black start capabilities
- Improved system reliability
- Improved system resilience

unifi consortium
universal interoperability for grid-forming inverters

www | in | YouTube | Email | UNIFI-2023-1-1

Grid-forming (GFM) Inverters Overview

The future power grid will include more inverter-based resources (IBRs) interfacing wind, solar, and batteries due to their cost-competitive nature and to fulfill societal system decarbonization goals. Our current power systems, which were originally designed around synchronous generators, need to adapt to assimilate higher percentages of IBRs. Grids with high levels of IBRs currently exist in small islanded systems but are quickly becoming a reality in larger systems. In these future grids, inverters will need to take on a more engaged role in ensuring system stability, frequency and voltage regulation, and black-start and islanding capabilities. These capabilities can be provided seamlessly by grid-forming (GFM) controls. In contrast, inverters offered with grid-following (GFL) controls which do not offer the full suite of these control capabilities readily.

GFM controls offer several technological advantages over GFL controls, including improved and stable operation in low system-strength regions, improved primary-frequency response (PFR) and fast-frequency response (FFR), and black-start capabilities, among others. These benefits can be translated into economic value, procured through three main value streams: participation in essential reliability-service markets, compensation for black-start capabilities, and improved system reliability and resilience. (See Figure 1.) Notably, these attributes span from unit-level owner benefits to system-wide operational benefits. We overview different aspects of these value streams in what follows.

Grid-following (GFL) Controls

- Maintain a constant output current phasor to control the active and reactive power injected by the IBR into the network in the sub-transient to transient time frame.
- They are inherently dependent on grid-strength and cannot operate in islanded mode or provide black-start capabilities.

1. Essential Reliability Services

- GFM IBRs can participate in essential reliability-service markets that include PFR or FFR.
- GFM controls can provide a stabilizing response, which may be compensated in future systems with high levels of IBRs.

2. Black-start Capabilities

- GFM IBRs that provide black-start capability can be compensated for offering that service.

3. Power Grid Reliability & Resilience

- GFM IBRs can offer improved system strength and stability and assist in power system restoration, which in turn can increase system reliability and resilience.
- GFM controls can help to increase the system hosting capacity, which enables continued seamless deployment of renewable technologies.

Figure 1: Summary of benefits of GFM inverters

Essential Grid Service Markets

IBRs, particularly batteries, can participate in essential reliability-service markets that include products for PFR and FFR. Both GFL and GFM IBRs can participate in these markets, but a benefit of GFM IBRs is that they include primary controls that are inherently frequency sensitive. Therefore, they are naturally suitable to regulate and restore grid frequency. A market for frequency response (including PFR and FFR) that encourages IBR participation only exists in ERCOT today, but may expand to other ISOs/RTOs in the future.

Grid-forming (GFM) Controls

- Maintain a constant internal voltage phasor & frequency, which is controlled to maintain synchronism with other devices and to regulate IBR active and reactive power in the sub-transient to transient time frame.
- Can provide black start and continue operation even in the absence of synchronous generators.

Global Landscape and Timeline for GFM Specifications

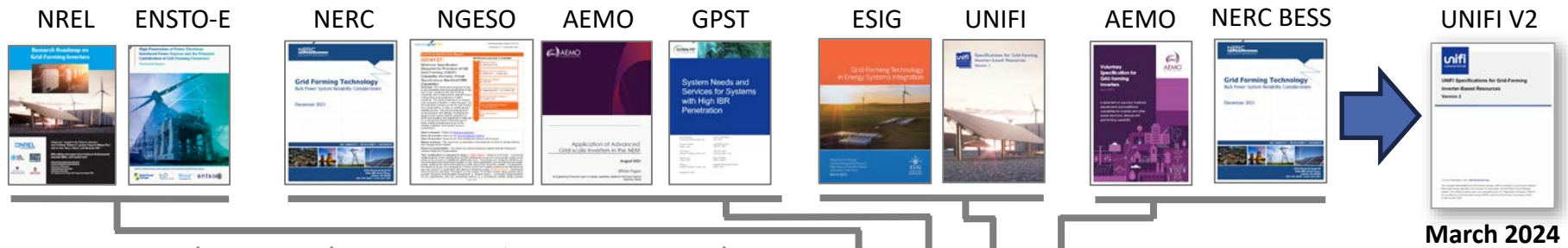

UL 1741 & IEEE 519
synchronize for IBRs
at distribution level

IEEE 1547 published

IBRs **shall**:

- Not regulate voltage
- Trip under abnormal voltage and frequency (anti-islanding)

IEEE 1547A Amendment

IBRs **may**:

- regulate voltage
- Ride-through abnormal voltage and frequency
- Provide frequency response

IEEE 1547-2018 published

IBRs **shall be capable of**:

- regulating voltage
- Ride-through abnormal voltage and frequency
- Provide frequency response

IEEE 2800 published

Extended & Improved specs for IBR at:

- Sub-transmission level
- Transmission Level

grid-following behavior

suggesting grid-forming behavior

- UNIFI GFM Specs Version 1 – Published in December 2022
- UNIFI GFM specs were used as the basis for the new NERC GFM Specs for Battery Systems (Sept 2023)
- **UNIFI GFM Specs Version 2 – Published in March 2024**

The **UNIFI Consortium** addresses the challenges of integrating **grid-forming (GFM) technologies** into electric power systems

Three major focuses:

- Research & Development
- Demonstration & Commercialization
- Outreach & Training

Started in 2022 by DOE, UNIFI is focused on bringing the industry together to unify the integration and operation of inverter-based resources and synchronous machines

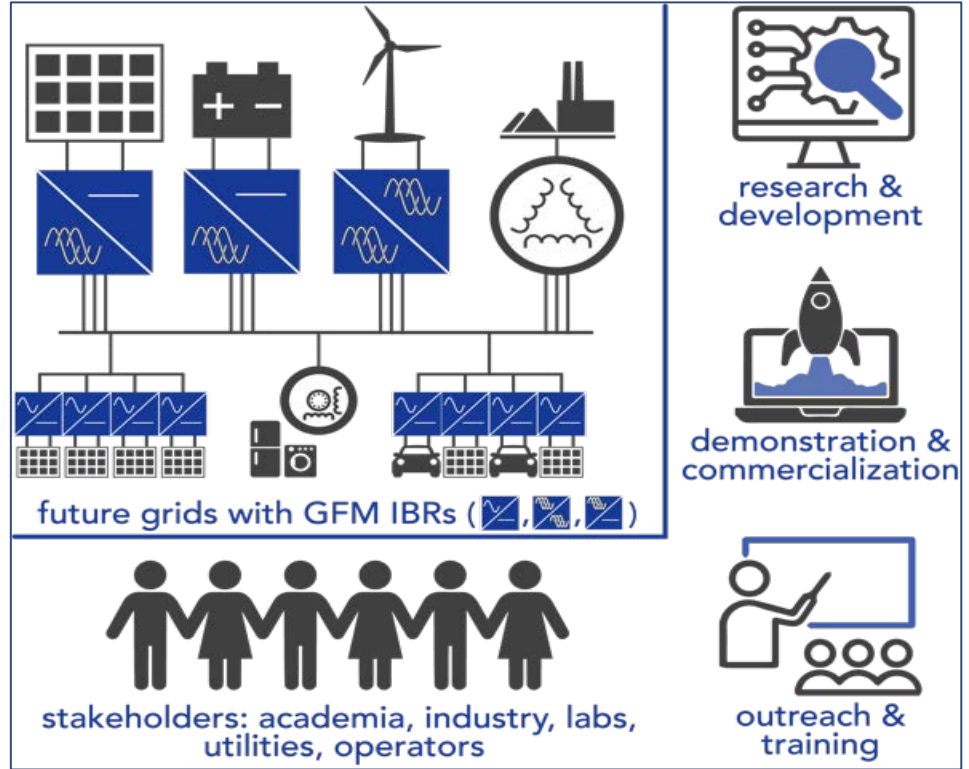

UNIFI - Working to Build Better Models

WECC

droop-based GFM model specification (REGFM_A1) has been adopted by WECC • this model is available in the model libraries of 4 commercial positive-sequence tools (PSS/E, PSLF, PowerWorld, and TSAT) •

PowerWorld

control blocks of REGFM_A1

PSCAD

EMT models of PV inverter based resource in GFL and GFM mode • model includes an interoperable primary control grid forming system architecture that is designed for use with both individual IBRs and aggregations • the design is intended to coexist with vendor specific proprietary controls that exchange standardized signals with the system operator to regulate frequency and voltages, or to manage black start •

EMTP

generic EMTP model for a three-phase aggregated grid-forming inverter (GFM inverter) • applications include stability, fault, harmonic, dynamic, and interconnection studies • the GFM inverter can be modeled as: droop-based, virtual synchronous machine (VSM)-based, dispatchable virtual oscillator (dVOC)-based, or a PLL-based •

unifi modeling & simulation technical area members helped electrical system planners at [ERCOT](#), [AEP](#), and [WECC](#) better understand benefits of GFM inverters – good first steps

Droop-based GFM model (REGFM_A1) and Virtual Synchronous Machine GFM model (REGFM_B1) are now available in commercial positive-sequence tools.

UNIFI – 20MW Field Demonstration



Photo: AES

Kauai ($80\text{MW}_{\text{peak}}$) is the only place in the world with multiple 10MW+ GFM systems in operation paralleled to grid.

The grid operator (KIUC) is successfully operating the grid at 90% inverter-based resources at times which translate to around 45% annually.

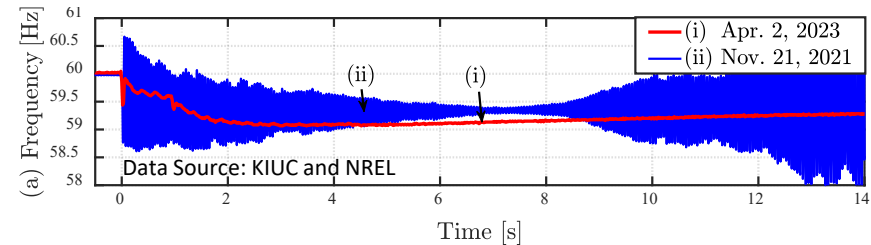

1 GFM operating 2 GFM operating

<https://spectrum.ieee.org/electric-inverter>

ERCOT – Current IBR Situation

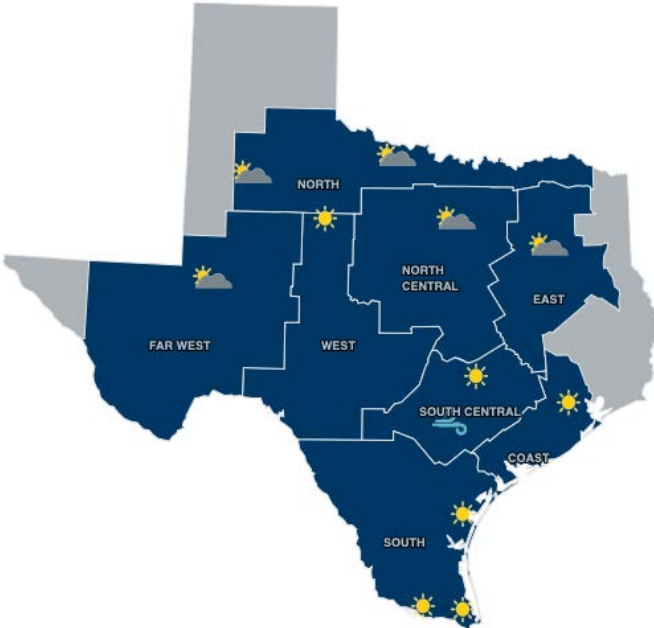

Currently there is a lot of existing invert-based resources (IBR) in the ERCOT system.

2024 Generating Capacity

Reflects operational installed capacity based on December 2023 CDR report for Summer 2024.

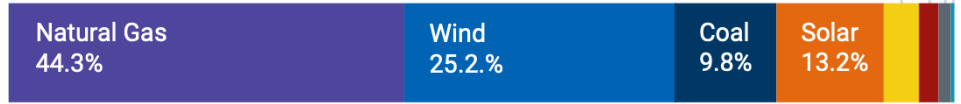

The sum of the percentages may not equal 100% due to rounding.
*Other includes biomass and DC Tie capacity.

2023 Energy Use

43% of installed capacity is IBRs

*Other includes solar, hydro, petroleum coke (pet coke), biomass, landfill gas, distillate fuel oil, net DC-tie and Block Load Transfer imports/exports and an adjustment for wholesale storage load.

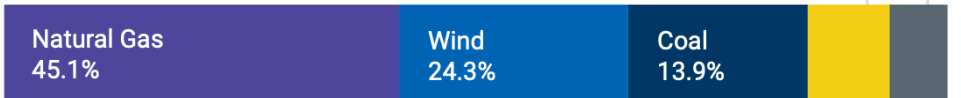

A new renewable penetration record of **75.67%** was set March 29 at 2:13 p.m. Renewable generation at record penetration time was 34,958 MW.

[ERCOT May 2024 Fact Sheet](#)

ERCOT – Current Operations

Operations on a Sunny, Windy Day - February 21, 2024

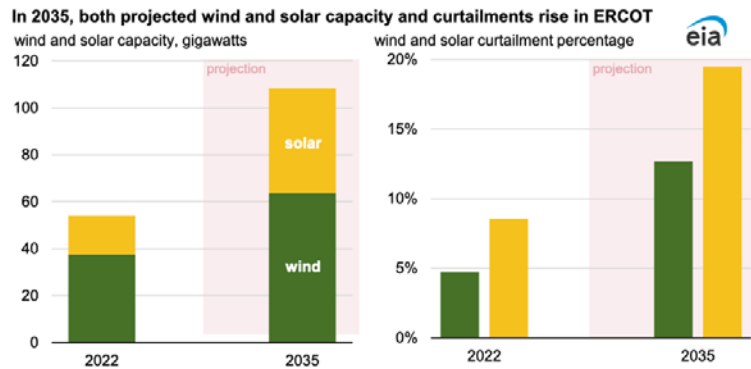
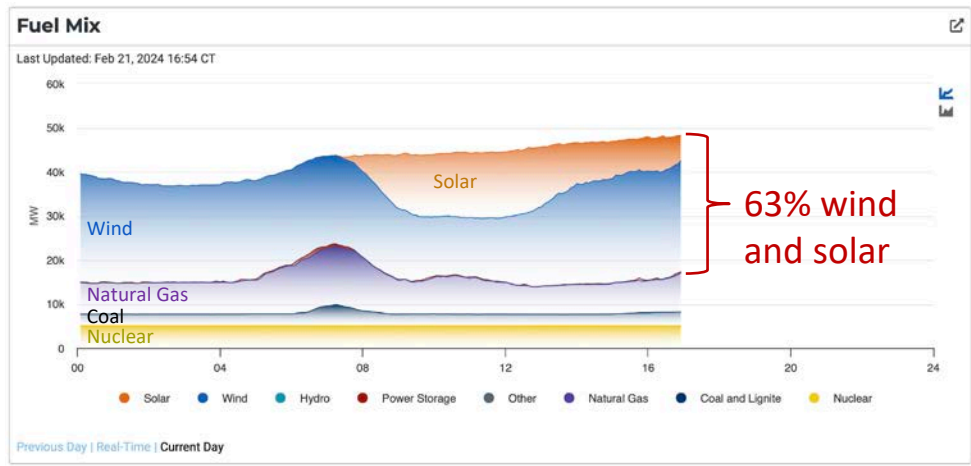
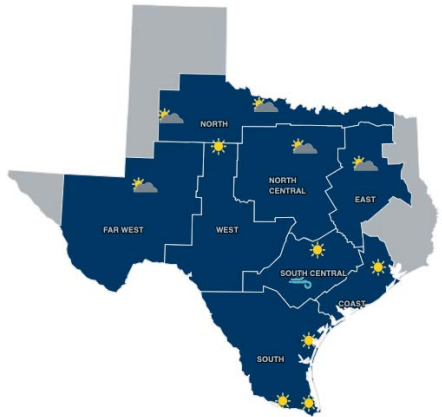

Data source: U.S. Energy Information Administration, UPLAN model simulation of ERCOT power market, and Potomac Economics, State of the Market Report for the ERCOT Electricity Market, May 2023

<https://www.eia.gov/todayinenergy/detail.php?id=57100>

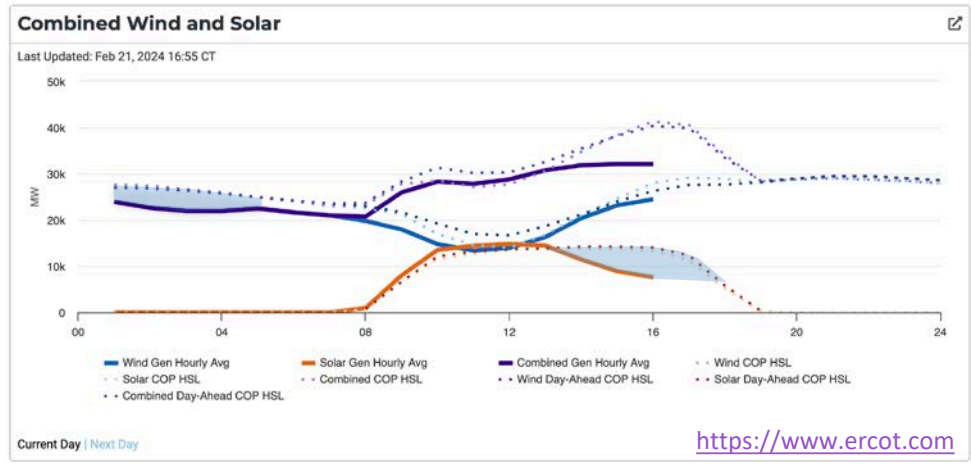

<https://www.ercot.com>

ERCOT – Moving forward

To successfully integrate higher levels of inverter-based variable renewables (wind and solar):

- Need to make sure all new large IBRs are responsive and help support stability – GFL IBR need to follow IEEE 2800
- New battery IBRs should have GFM capability built in – this will be needed to get to higher IBR levels and maintain grid stability
- More storage will be required to turn off conventional generators currently running at minimum load
- Important to act soon before too much IBRs are deployed





Thank you

NREL/PR-5D00-90256

This work was authored by the National Renewable Energy Laboratory, operated by Alliance for Sustainable Energy, LLC, for the U.S. Department of Energy (DOE) under Contract No. DE-AC36-08GO28308. The views expressed in the article do not necessarily represent the views of the DOE or the U.S. Government. The U.S. Government retains and the publisher, by accepting the article for publication, acknowledges that the U.S. Government retains a nonexclusive, paid-up, irrevocable, worldwide license to publish or reproduce the published form of this work, or allow others to do so, for U.S. Government purposes.

Visit the UNIFI website:
unificonsortium.org

Additional Material

Technical Challenges with Higher Inverter-based Resources

Challenges:

- Frequency Stability (Lower System Inertia)
- Voltage Stability and Regulation
- System Protection
- Grid Forming capability
- Black Start capability
- Control system interactions and resonances
- Cybersecurity

Source: B. Kroposki et al., "Achieving a 100% Renewable Grid – Operating Electric Power Systems with Extremely High Levels of Variable Renewable Energy," <http://ieeexplore.ieee.org/document/7866938/>

Source: Blackstart of Power Grids with Inverter- Based Resources, H. Jain, G. Seo, E. Lockhart, V. Gevorgian, B. Kroposki, 2020 IEEE Power and Energy General Meeting: <https://www.nrel.gov/docs/fy20osti/75327.pdf>

Stability

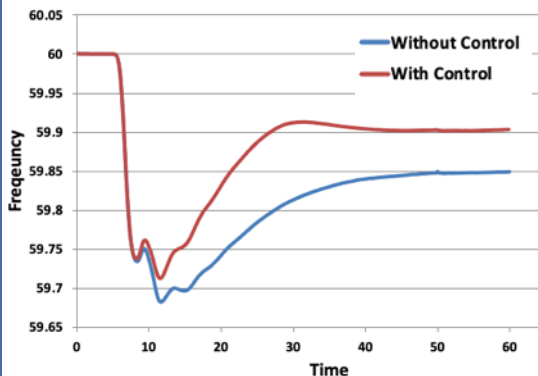

Protection

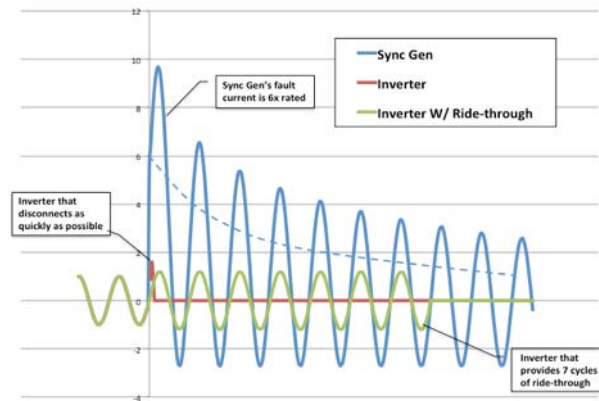

Grid-forming/Blackstart

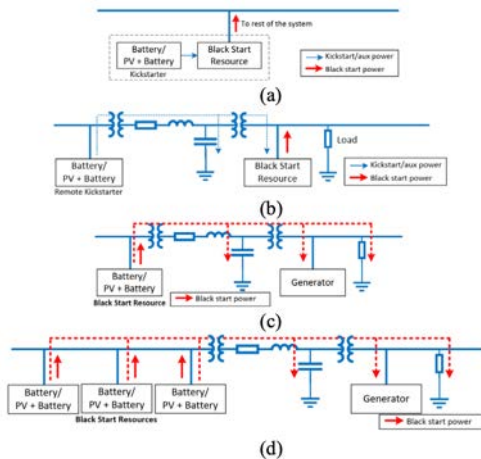

Control system interactions and resonances

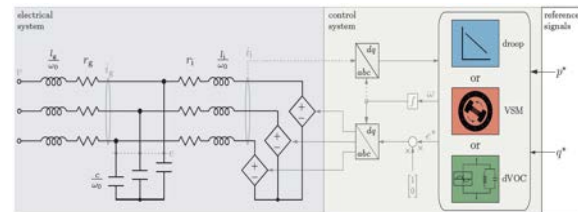

Power System Oscillations

UNIFI Specifications for GFM Technologies – V2



UNIFI Specifications for Grid-Forming Inverter-Based Resources Version 2



For more information, visit: unificonsortium.org

The Universal Interoperability for Grid-Forming Inverters (UNIFI) Consortium is co-led by the National Renewable Energy Laboratory, the University of Texas-Austin, and the Electric Power Research Institute. This material is based upon work supported by the U.S. Department of Energy's Office of Energy Efficiency and Renewable Energy (EERE) under the Solar Energy Technologies Office Award Number 38637.

Table of Contents

Table of Contents	3
1 Overview	4
1.1 Grid Forming (GFM) Controls.....	5
1.2 Scope	7
1.3 Purpose.....	7
1.4 Limitations	7
2 Universal Performance Requirements for GFM IBRs	8
2.1 Performance Requirements for Operation Within Normal Grid Operating Conditions.....	8
2.1.1 Autonomously Support the Grid	8
2.1.2 Dispatchability of Power Output	9
2.1.3 Provide Positive Damping of Voltage and Frequency Oscillations	9
2.1.4 Active and Reactive Power Sharing across Generation Resources.....	10
2.1.5 Operation in Grids with Low System Strength	10
2.1.6 Operation Under System Unbalance	11
2.2 Performance Requirements for Operation Outside Normal Conditions.....	11
2.2.1 Ride-through Behavior	11
2.2.2 Response to Symmetrical Faults	12
2.2.3 Response to Asymmetrical Faults	13
2.2.4 Response to Abnormal Frequency	13
2.2.5 Response to Phase Jumps and Voltage Steps.....	13
3 Additional GFM Capabilities and Considerations	14
3.1 Intentional Islanding.....	14
3.2 Black Start and System Restoration	14
3.3 Regulating Voltage Harmonics	15
3.4 Communications between System Operator and IBR plant	15
3.5 Secondary Voltage and Frequency Signal Response	16
4 Modeling and Documentation	16
References	17
Bibliography	18

UNIFI - GFM Definition

The UNIFI Consortium defines GFM IBR controls as follows in accordance with the North American Electric Reliability Corporation (NERC) definition:

“GFM IBR controls maintain an internal voltage phasor that is constant or nearly constant in the sub-transient to transient time frame.”

This definition means that the GFM IBR will nearly immediately respond to changes in the external system and attempt to maintain IBR control during challenging network conditions to maintain grid stability. In GFM IBR, the voltage phasor is controlled to maintain synchronism with other devices in the grid while regulating the active and reactive power appropriately to support the grid.

UNIFI - IBR Categories

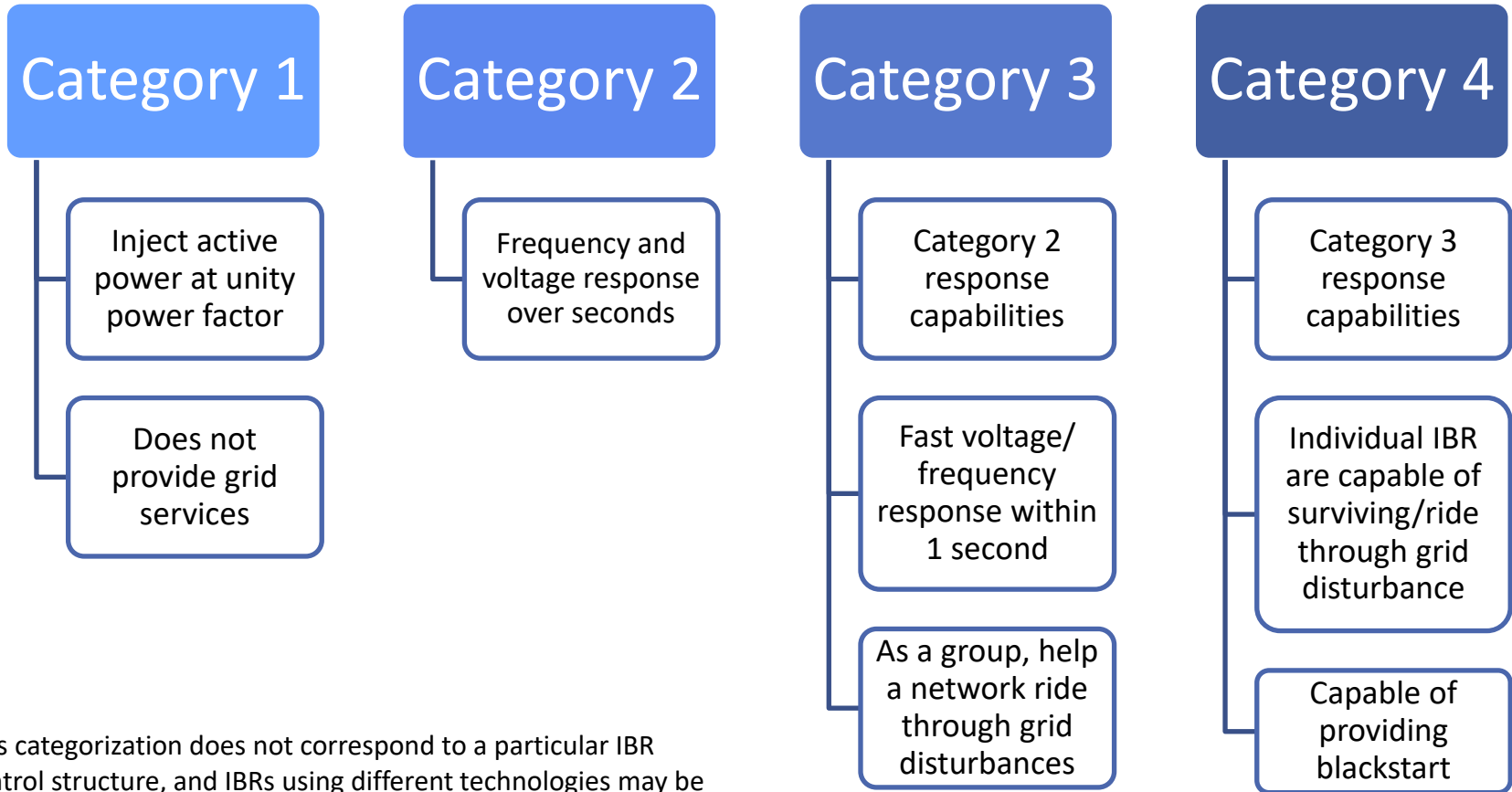

This categorization does not correspond to a particular IBR control structure, and IBRs using different technologies may be categorized in the same category if they provide similar services.

When do we need GFM and How much do we need?

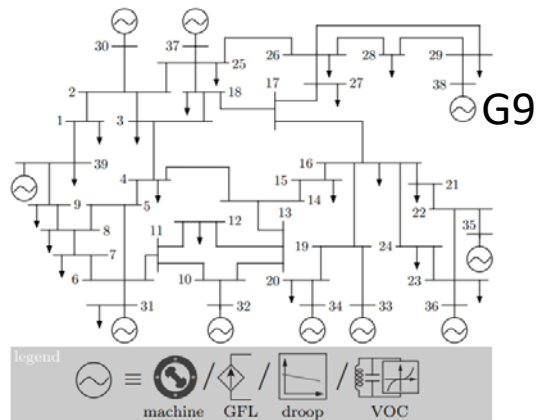

IEEE 39-bus test system

**GFM controls
showed no
instability**

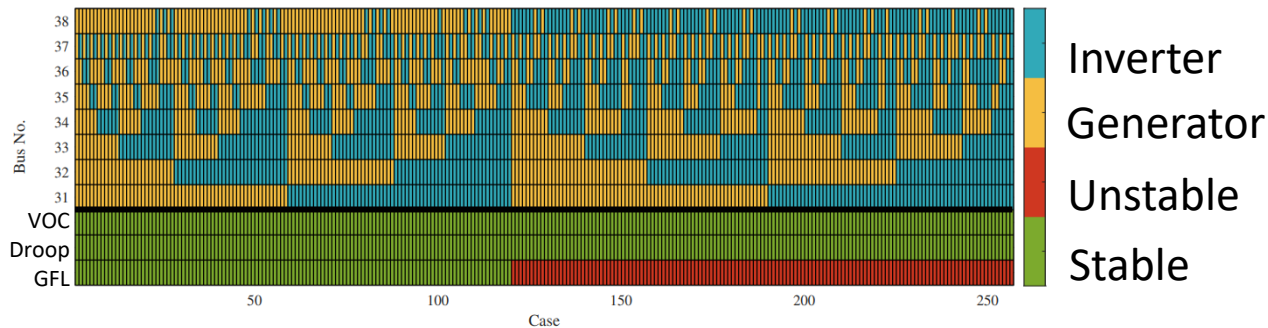

Stable and unstable configurations evaluate with an exhaustive combination of:

- synchronous generators
- droop-controlled grid-forming (GFM) inverters
- virtual oscillator control (VOC) grid-forming (GFM) inverters
- grid-following (GFL) inverters

Key Results

- Stability depends on system characteristics, types of disturbances, nominal V/f ranges
- Stability issues increase as GFL IBR penetration increases – especially above 60% instantaneous
- Systems can have corner cases at low IBR penetrations – especially in weak parts of the system

When do we need GFM and How much do we need?

Similar Results on the Australian NEM Power System

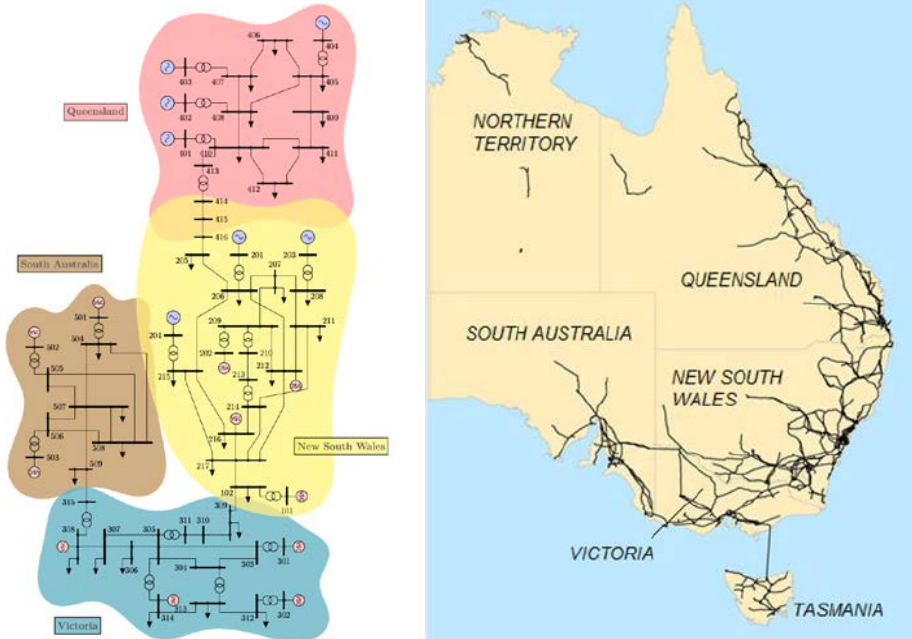

- Stability issues increase as GFL IBR penetration increases – especially above 60% - 70% instantaneous levels
- GFM can increase stability levels dramatically
- Location of GFM in systems is a significant contributor to system stability – GFM should be placed at weak points in grid

UNIFI – 1MW Multi-Vendor Experiment

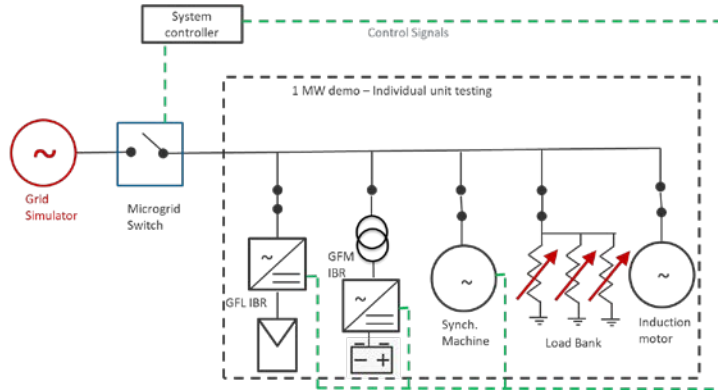

- Evaluating multi-vendor GFM IBR in controllable environment
- Using the same testing circuit for easy configuration and testing
- Using the same testing protocol for fair comparison between vendors
 - Power quality
 - Overloading capability
 - Transient stability
- A system controller dispatches all the elements
- Evaluating single and multiple vendor GFM performance against UNIFI GFM specs



NERC GFM Whitepaper

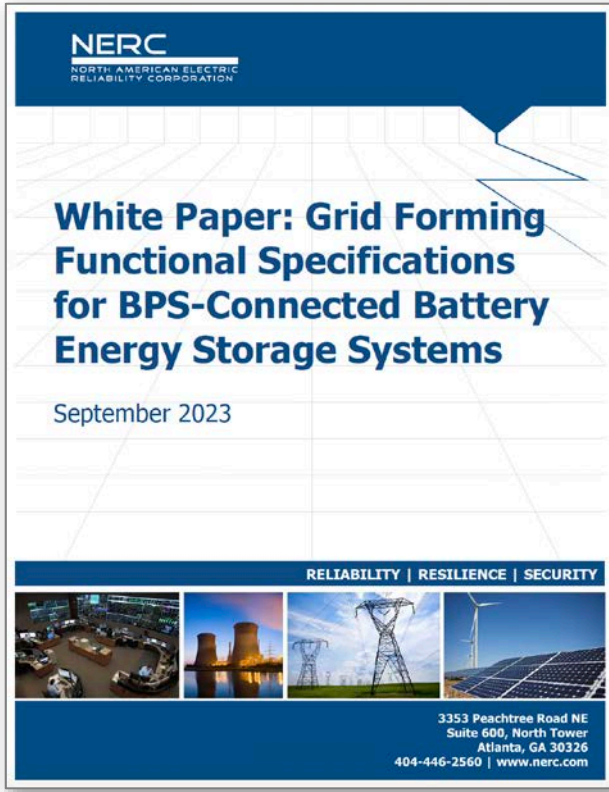

- GFM technology has been shown to operate reliably and provide stabilizing characteristics in transmission in areas of high IBR penetrations
- GFM technology is commercially available and field-proven - particularly for BESS
- All newly interconnecting BPS-connected BESS should be designed and commissioned with GFM controls
- Transmission Operators should begin the process of establishing GFM functional specifications for BESS
- Testing and validation of GFM performance is still needed

For more information

Y. Lin, J. Eto, B. Johnson, J. Flicker, R. Lasseter, H. Villegas Pico, G. Seo, B. Pierre, and A. Ellis. 2020. *Research Roadmap on Grid-Forming Inverters*. Golden, CO: National Renewable Energy Laboratory. NREL/TP-5D00-73476.

<https://www.nrel.gov/docs/fy21osti/73476.pdf>

UNIFI Consortium, *UNIFI Specifications for Grid-Forming Inverter-Based Resources— Version 2*. UNIFI-2024-2-1. March 2024.

<https://www.nrel.gov/docs/fy24osti/89269.pdf>

B. Kroposki and A. Hoke, "A Path to 100 Percent Renewable Energy: Grid-Forming Inverters will Give Us the Grid We Need Now," in *IEEE Spectrum*, vol. 61, no. 5, pp. 50-57, May 2024, doi: 10.1109/MSPEC.2024.10523014

<https://ieeexplore.ieee.org/document/10523014>

B. Bahrani et al., "Grid-Forming Inverter-Based Resource Research Landscape: Understanding the Key Assets for Renewable-Rich Power Systems," in *IEEE Power and Energy Magazine*, vol. 22, no. 2, pp. 18-29, March-April 2024, doi:

10.1109/MPE.2023.3343338. <https://ieeexplore.ieee.org/document/10444681>

S. Shah et al., "A Testing Framework for Grid-Forming Resources," 2023 IEEE Power & Energy Society General Meeting (PESGM), Orlando, FL, USA, 2023, pp. 1-5, doi: 10.1109/PESGM52003.2023.10252438. <https://ieeexplore.ieee.org/document/10252438>

D. Ramasubramanian et al., "Performance Specifications for Grid-forming Technologies," 2023 IEEE Power & Energy Society General Meeting (PESGM), Orlando, FL, USA, 2023, pp. 1-5, doi: 10.1109/PESGM52003.2023.10253440.

<https://ieeexplore.ieee.org/document/10253440>

For more information

Y. Lin, G. Seo, s. Vijayshankar, B. Johnson, S. Dhople, "Impact of Increased Inverter-based Resources on Power System Small-signal Stability," IEEE PESGM, 2021 <https://ieeexplore.ieee.org/document/9638094>

F. Milano, F. Dörfler, G. Hug, D. J. Hill and G. Verbič, "Foundations and Challenges of Low-Inertia Systems (Invited Paper)," 2018 Power Systems Computation Conference (PSCC), Dublin, Ireland, 2018, pp. 1-25, <https://ieeexplore.ieee.org/document/8450880>

A. Crivellaro *et al.*, "Beyond low-inertia systems: Massive integration of grid-forming power converters in transmission grids," 2020 IEEE Power & Energy Society General Meeting (PESGM), Montreal, QC, Canada, 2020, pp. 1-5, <https://ieeexplore.ieee.org/document/9282031>

U. Markovic, O. Stanojev, P. Aristidou, E. Vrettos, D. Callaway and G. Hug, "Understanding Small-Signal Stability of Low-Inertia Systems," in *IEEE Transactions on Power Systems*, vol. 36, no. 5, pp. 3997-4017, Sept. 2021, <https://ieeexplore.ieee.org/document/9361257>

L. Ding, X. Lu and J. Tan, "Small-Signal Stability Analysis of Low-Inertia Power Grids with Inverter-Based Resources and Synchronous Condensers," 2022 IEEE Power & Energy Society Innovative Smart Grid Technologies Conference (ISGT), New Orleans, LA, USA, 2022, <https://ieeexplore.ieee.org/document/9817556>



Other papers and tutorials on GFM available at www.unificonsortium.org