



# Wireless Pulse-Width Modulation Control of Power Converters Using Ultra-Wideband Technology for Distributed High-Voltage Systems

Preprint

Sarwar Islam and Faisal Khan

*National Renewable Energy Laboratory*

*Presented at the IEEE Energy Conversion Conference and Expo  
Phoenix, Arizona  
October 20 – 24, 2024*

**NREL is a national laboratory of the U.S. Department of Energy  
Office of Energy Efficiency & Renewable Energy  
Operated by the Alliance for Sustainable Energy, LLC**

This report is available at no cost from the National Renewable Energy Laboratory (NREL) at [www.nrel.gov/publications](http://www.nrel.gov/publications).

Contract No. DE-AC36-08GO28308

**Conference Paper**  
NREL/CP-5400-90684  
October 2024



# Wireless Pulse-Width Modulation Control of Power Converters Using Ultra-Wideband Technology for Distributed High-Voltage Systems

## Preprint

Sarwar Islam and Faisal Khan

*National Renewable Energy Laboratory*

### Suggested Citation

Islam, Sarwar and Faisal Khan. 2024. *Wireless Pulse-Width Modulation Control of Power Converters Using Ultra-Wideband Technology for Distributed High-Voltage Systems: Preprint*. Golden, CO: National Renewable Energy Laboratory. NREL/CP-5400-90684. <https://www.nrel.gov/docs/fy25osti/90684.pdf>.

© 2024 IEEE. Personal use of this material is permitted. Permission from IEEE must be obtained for all other uses, in any current or future media, including reprinting/republishing this material for advertising or promotional purposes, creating new collective works, for resale or redistribution to servers or lists, or reuse of any copyrighted component of this work in other works.

**NREL is a national laboratory of the U.S. Department of Energy  
Office of Energy Efficiency & Renewable Energy  
Operated by the Alliance for Sustainable Energy, LLC**

This report is available at no cost from the National Renewable Energy Laboratory (NREL) at [www.nrel.gov/publications](http://www.nrel.gov/publications).

Contract No. DE-AC36-08GO28308

**Conference Paper**  
NREL/CP-5400-90684  
October 2024

National Renewable Energy Laboratory  
15013 Denver West Parkway  
Golden, CO 80401  
303-275-3000 • [www.nrel.gov](http://www.nrel.gov)

## NOTICE

This work was authored by the National Renewable Energy Laboratory, operated by Alliance for Sustainable Energy, LLC, for the U.S. Department of Energy (DOE) under Contract No. DE-AC36-08GO28308. This work was supported by the Laboratory Directed Research and Development (LDRD) Program at NREL. The views expressed herein do not necessarily represent the views of the DOE or the U.S. Government. The U.S. Government retains and the publisher, by accepting the article for publication, acknowledges that the U.S. Government retains a nonexclusive, paid-up, irrevocable, worldwide license to publish or reproduce the published form of this work, or allow others to do so, for U.S. Government purposes.

This report is available at no cost from the National Renewable Energy Laboratory (NREL) at [www.nrel.gov/publications](http://www.nrel.gov/publications).

U.S. Department of Energy (DOE) reports produced after 1991 and a growing number of pre-1991 documents are available free via [www.OSTI.gov](http://www.OSTI.gov).

*Cover Photos by Dennis Schroeder: (clockwise, left to right) NREL 51934, NREL 45897, NREL 42160, NREL 45891, NREL 48097, NREL 46526.*

NREL prints on paper that contains recycled content.

# Wireless Pulse-Width Modulation Control of Power Converters Using Ultra-Wideband Technology for Distributed High-Voltage Systems

Sarwar Islam  
National Renewable Energy Laboratory  
Golden, CO USA  
Sarwar.Islam@nrel.gov

Faisal Khan  
National Renewable Energy Laboratory  
Golden, CO USA  
Faisal.Khan@nrel.gov

**Abstract**—In this study, we present a new approach for wireless pulse-width modulation (PWM) control of a power converter, applicable to numerous power converters within a complex electrical distribution system. This method eliminates the need for multiple physical connections of gating/PWM signals among distributed converter modules. By using ultra-wideband-based communication, the PWM control signals can be wirelessly transmitted from a central controller to multiple converters simultaneously and seamlessly. System stability is thoroughly analyzed, and experimental results validate the efficacy of the wireless control scheme for a buck converter operating at a 50-kHz switching frequency. The minimum latency obtained from this setup is 5.38  $\mu$ s. This control concept offers easier implementation of distributed control in high-voltage power systems, especially in multilevel architectures, even under harsh conditions with ambient noise.

**Keywords**—pulse-width modulation (PWM), wireless PWM, low-latency wireless communication, ultra-wideband communication, wireless gate driver

## I. INTRODUCTION

Maintaining galvanic isolation between the control and power sections is essential in any power converter. Over the years, various techniques have been developed to achieve this, including optocouplers, pulse transformers, and fiber optics—all of which are well-established technologies [1]–[3]. However, when operating power converters at high voltages, these methods have shown certain drawbacks, such as limited bandwidth and nonlinear response in optocouplers, size constraints and limited frequency response in pulse transformers, and high cost and fragility in fiber optics [4]. To address these challenges, wireless communication emerges as a promising solution between the control and power systems. Although widely used wireless protocols like Wi-Fi, Bluetooth, and Near-Field Communication offer higher data bandwidth and range, they suffer from considerable latency as high as 50 ms, rendering them unsuitable for power converter control loops. The average Wi-Fi data latency is in the range of 20–25 ms [5], [6], though Wi-Fi 7 (802.11be) is proposed to be as low as 1 ms [7], [8]. In contrast, Bluetooth Low Energy latency typically ranges from 30 to 150 ms [9], with Qualcomm’s update reducing it to 20 ms [10]. To address latency issues, alternatives like ultra-reliable low-latency communications (URLLC),

WirelessHART, 60-GHz communication, and ultra-wideband (UWB) technology are explored [11]. URLLC achieves latency as low as 0.5 ms [12], [13], while WirelessHART offers 2–100 ms depending on data volume [14]. Additionally, 60-GHz communication and UWB provide sub-millisecond latency [15], [16]. UWB technology is also known for its impressive performance, offering sub-millisecond latency [15]. For instance, SPARK Microsystems’ wireless audio system, developed based on UWB technology, demonstrates tight synchronization within 20  $\mu$ s [16]. Although various newer communication technologies hold potential for a wireless gate driver, we selected UWB for its cost effectiveness, low power consumption, superior penetration capabilities, and minimal interference. A key factor is that UWB signals are inherently challenging to intercept and eavesdrop on due to their low power, wide bandwidth, and short-duration pulses. To our knowledge, this is the first time UWB communication is being used to wirelessly control power converters, which is the obvious next step from the Wi-Fi pulse-width modulation (PWM) gate driver circuit developed by the National Renewable Energy Laboratory in 2022. We have plans to integrate this scheme with the wireless gate driver circuit. This setup will drive the Ga<sub>2</sub>O<sub>3</sub>-based power module at extremely high voltage levels, reaching around 20 kV [17].

### A. UWB Communication

UWB is a short-range wireless communication protocol that operates at very high frequencies (3.1–10.6 GHz) [18]. UWB uses very short, rapid pulses of energy to transmit data, which allows for high data rates and low latency [19]. UWB is primarily used for short-range, precise location sensing. By measuring the time it takes for signals to travel between devices, UWB determines distances with picosecond accuracy using specialized chips. This technology allows for pinpoint location tracking, achieving impressive 10-cm accuracy. Though this is widely used for location tracking, it has full capabilities of wireless data transfer for short ranges (up to 25 m) [20].

### B. Power Converter Control System

The control system plays a crucial role in every power converter, regardless of whether it operates with open-loop

or closed-loop control. Its main function is to generate appropriate excitation signals for power semiconductor switches, typically generated using a digital circuit and then transformed into suitable gate signals using a gate driver circuit. The gate driver acts as a vital bridge between the low-voltage and high-voltage systems, hence acting as a current buffer too. However, it is also the most vulnerable component, particularly when it comes to failure due to voltage stress. Such failures can lead to catastrophic consequences, affecting the entire control system. To address this issue, one promising solution is to replace all physical connections between the control system and the high-voltage system with wireless communication, which can eventually enhance reliability and safety in high-voltage power conversion systems.

### C. Wireless Communication in Power Converters

Researchers have extensively explored wireless communication in power converters. Ref. [21] focuses on wirelessly controlled PWM voltage-source converters, analyzing stability and the effects of delay, though it does not show any experimental validation. Another paper [22] investigates wireless space vector PWM for long-distance communication, achieving successful signal generation and radio frequency (RF) link establishment. This work uses 2.4-GHz nRF wireless communication, which has a latency in the range of several milliseconds. Similarly, [23] showcases wireless PWM control for a two-module DC-DC buck converter, ensuring load current sharing. Additionally, [24] presents a parallel DC-DC converter design with successful RF-controlled regulation of output voltage, though the communication is not secured. Lastly, [25] and [26] highlight 60-GHz communication for transmitting gate control signals in power devices. Though this approach achieves low latency, it requires complex, field-programmable gate array-based, and custom-designed RF integrated circuits. Addressing these limitations, UWB might be the best choice, as it has extremely low latency and, due to its inherent burst mode nature, is secure and can easily coexist with other protocols.

## II. EXPERIMENTAL SETUP AND TEST RESULTS

### A. Latency Measurement

This experiment setup uses two UWB transceiver evaluation boards. One is configured as a transmitter (master) and the other as a receiver (slave). This experiment was conducted in two steps. In the first step, upon each transmission by the master, it will alter the state of a general-purpose input-output (GPIO) pin on the host microcontroller unit (MCU) of the evaluation board. Similarly, upon receiving a signal, the slave will toggle the state of a GPIO pin on its host MCU. To measure latency, the master will transmit five consecutive transmissions. The oscilloscope will then capture the GPIO output of both the transmitter and the receiver. Fig. 1 illustrates the test setup. Fig. 2 illustrates the captured waveform during the experiment. The blue waveform is captured from the transmitter board, while the purple waveform is captured from the receiver board. As previously

stated, the edges of the captured pulses represent transmission and reception events for the respective boards. Fig. 3 illustrates the latency measurement between TX\_Event\_1 and RX\_Event\_1. Similar latency measurements for all other TX/RX events were conducted, and the average latency across these five events was found to be 5.38  $\mu$ s.



Fig. 1. Latency measurement between two transceivers.

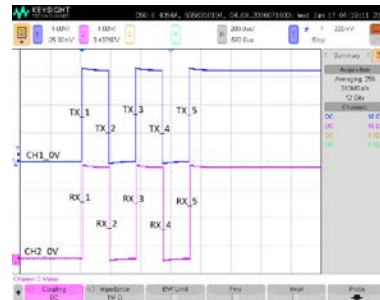

Fig. 2. Transmitted and received signals.

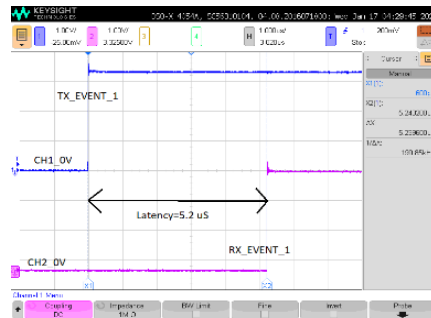

Fig. 3. Latency measurement.

During the second step, the transmitter’s MCU produces a PWM signal, cyclically varying its duty cycle between 20% and 80%, which we named “wired PWM.” While generating this PWM, the transmitter also sends the duty ratio information to the receiver. After receiving the data, the MCU at the receiver end generates a corresponding PWM signal, which we refer to as “wireless PWM.” Fig. 4 illustrates the block diagram of the test setup. Fig. 5 displays both PWM signals, with the yellow representing the wired PWM and the green representing the wireless PWM. The oscilloscope is configured to trigger capturing when the duty cycle changes from 80% to 20% in the transmitter. This setup ensures synchronism between the transmitter and receiver end pulses, enabling accurate latency measurement. In this experiment, the measured latency is 5.6  $\mu$ s.



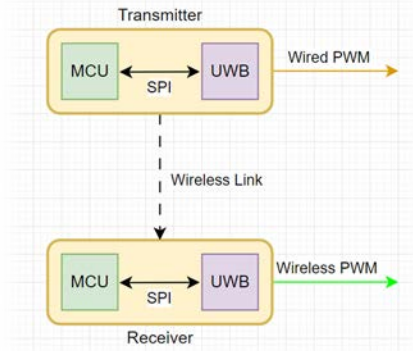

Fig. 4. Block diagram of the latency test using both wired and wireless PWM.

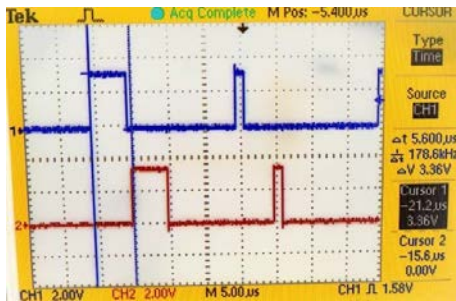

Fig. 5. Experimental result of latency test.

### B. Performance Analysis in a Closed-Loop DC-DC Converter

To evaluate the performance of the entire control scheme, we constructed a synchronous buck converter, and the test setup is shown in Fig. 6. The MCU at the receiver end takes the voltage feedback from the buck converter and sends it back to the transmitter. Based on this, the MCU at the transmitter end calculates the duty ratio using a discrete Proportional-Integral (PI) controller and sends the information to the receiver end. Then the MCU at the receiver end generates PWM based on this information. The PWM frequency is chosen at 50 kHz, and the bandwidth of the PI controller is set at 5 kHz. These values are selected because most high-power converters operate with a switching frequency of 10–50 kHz. Additionally, a one-tenth bandwidth for the control loop works satisfactorily for most practical applications. The buck converter’s input voltage was 24 V, and it was configured to generate 12 V at the output. Fig. 7 shows both the open-loop and closed-loop step responses when the load changes from 1 A to 10 A. The analysis of the closed-loop response demonstrates the proper operation of the control loop while using wireless PWM control.

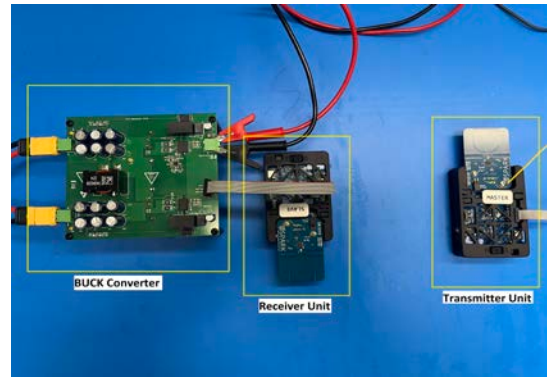

Fig. 6. Experimental setup with buck converter

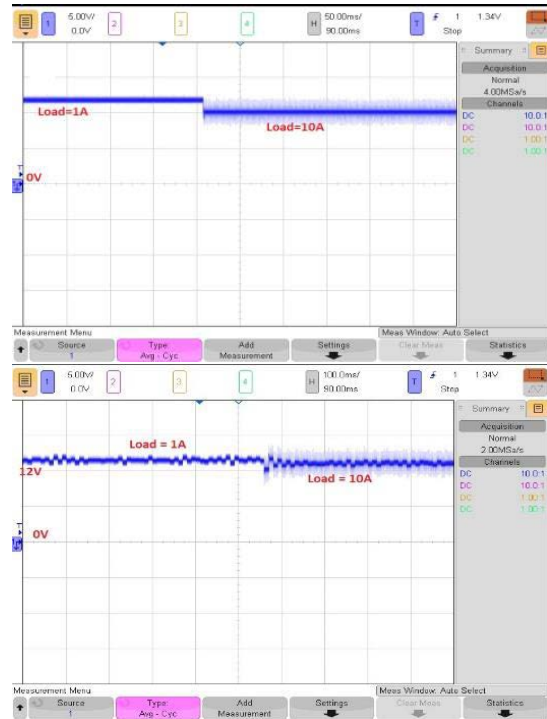

Fig. 7. (Top) Open-loop response and (bottom) closed-loop response.

### C. Transmitted PWM Signal for Sine Wave Modulation

For this experiment, a 1-kHz sinusoidal PWM (SPWM) signal was transmitted, and the received signal was compared with the transmitted one to evaluate the latency. The latency was measured to be 5.34 μs. Fig 8 shows the transmitted and received SPWM signals and latency between them.

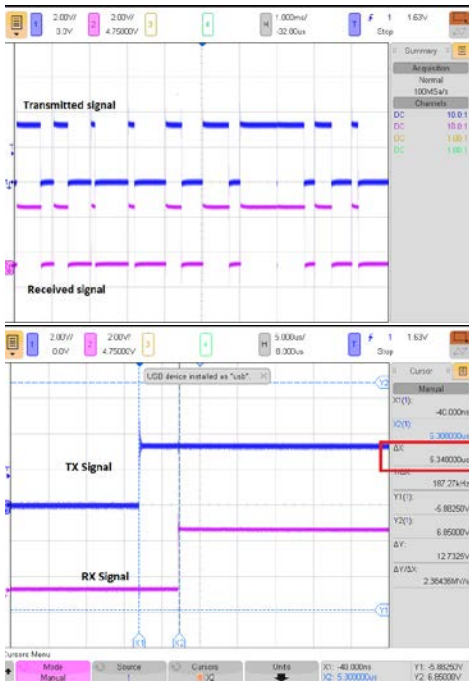

Fig. 8. (Top) Transmitted and received SPWM signal; (bottom) latency between transmitted and received SPWM.

#### D. Final Gate Driver Hardware Design

The satisfactory experimental results convinced us to start designing the final version of the UWB-enabled wireless gate driver for SiC power modules. The electronic computer-aided design (ECAD) is completed in a very compact footprint (61 mm × 41 mm), and this stand-alone half-bridge driver can be daisy chained with two others to build a complete six-pack driver. Additionally, some other peripherals (e.g., state-of-health monitor) and various protection and feedback modules can also be integrated through the onboard expansion connector. Fig. 9 (top) illustrates the 3D ECAD model of the stand-alone gate driver, and Fig. 9 (bottom) shows the gate driver prototype integrated with a half-bridge module from Cree. This gate driver is still under development, as we are working on the antenna optimization.

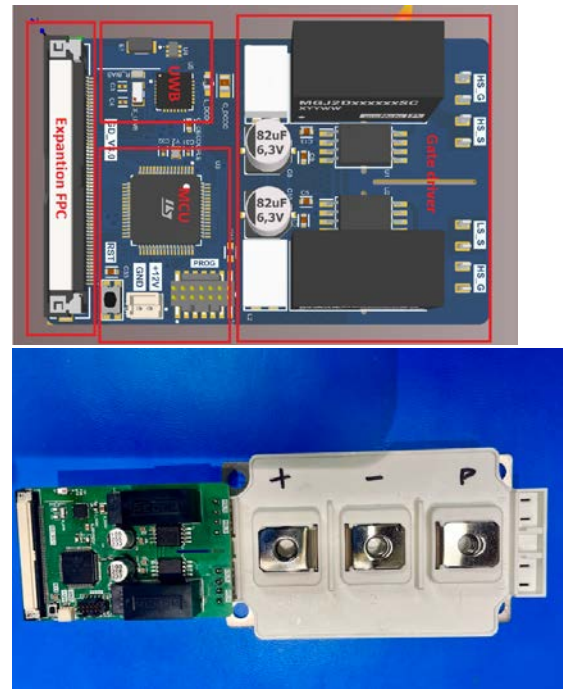

Fig. 9. (Top) Different sections of the final gate driver; (bottom) gate driver prototype.

### III. CONCLUSIONS AND FUTURE WORK

For the first time, a UWB communication-based wireless gate driver has been demonstrated, with initial test results showing highly promising outcomes. Without accessing the physical layer, we achieved a latency of 5.4  $\mu$ s. We strongly believe this latency can be significantly reduced to sub-microsecond levels by accessing the UWB hardware's physical layer. This technique is unique compared to existing solutions, as it utilizes all conventional off-the-shelf components and a well-defined communication protocol. Additionally, UWB is inherently immune to external interference, making it suitable for operation in harsh environments. Furthermore, we are conducting a frequency domain analysis of the DC-DC converter to understand the effect of latency on the overall control system stability and system dynamics. In the near future, we plan to test this topology in medium- and high-voltage distributed systems and pulsed power applications.

#### ACKNOWLEDGEMENTS

This work was authored by the National Renewable Energy Laboratory, operated by Alliance for Sustainable Energy, LLC, for the U.S. Department of Energy (DOE) under Contract No. DE-AC36-08GO28308. Funding provided by the NREL Laboratory Directed Research and Development Program. The views expressed in the article do not necessarily represent the views of the DOE or the U.S. Government. The U.S. Government retains and the publisher, by accepting the article for publication, acknowledges that the U.S. Government retains a nonexclusive, paid-up, irrevocable, worldwide license to publish or reproduce the published form

of this work, or allow others to do so, for U.S. Government purposes.

## REFERENCES

- [1] D. Rothmund, D. Bortis, and J. W. Kolar, "Highly compact isolated gate driver with ultrafast overcurrent protection for 10 kV SiC MOSFETs," in *CPSS Transactions on Power Electronics and Applications*, vol. 3, no. 4, pp. 278-291, Dec. 2018, doi: 10.24295/CPSSPEA.2018.00028.
- [2] Y. Liang, "Intelligent Automotive Isolated Gate Driver with Adaptive Fault Management and Built-in Switched Mode Power Supply," *2020 IEEE Applied Power Electronics Conference and Exposition (APEC)*, New Orleans, LA, USA, 2020, pp. 2643-2646, doi: 10.1109/APEC39645.2020.9124504.
- [3] H. Fujita and M. Ishigaki, "A resonant gate-drive circuit with optically-isolated control signal and power supply for fast-switching and high-voltage power semiconductor devices," *The 2010 International Power Electronics Conference – ECCE ASIA*, Sapporo, Japan, 2010, pp. 1895-1901, doi: 10.1109/IPEC.2010.5542024.
- [4] K. Mainali, S. Madhusoodhanan, A. Tripathi, K. Vechalapu, A. De, and S. Bhattacharya, "Design and evaluation of isolated gate driver power supply for medium voltage converter applications," *2016 IEEE Applied Power Electronics Conference and Exposition (APEC)*, Long Beach, CA, USA, 2016, pp. 1632-1639, doi: 10.1109/APEC.2016.7468085.
- [5] T. Høiland-Jørgensen, M. Kazior, D. That, P. Hurtig, and A. Brunstrom, "Ending the anomaly: Achieving low latency and airtime fairness in WiFi," pp. 139-151, 2017
- [6] C. Pei, Y. Zhao, L. Yunxin, K. Tan, J. Zhang, Y. Meng, et al., "Latency-based WiFi congestion control in the air for dense WiFi networks", 2017.
- [7] C. A. Grazia, "Towards 1 ms WLAN Latency," *2018 14<sup>th</sup> International Conference on Wireless and Mobile Computing, Networking and Communications (WiMob)*, Limassol, Cyprus, 2018, pp. 278-284, doi: 10.1109/WiMOB.2018.8589131.[8] T. Adame, M. Carrascosa-Zamacois, and B. Bellalta, "Time-Sensitive Networking in IEEE 802.11be: On the Way to Low-Latency WiFi 7," *Sensors (Basel)*, vol. 21, no. 15, p. 4954, 2021. Doi: 10.3390/s21154954. PMID: 34372190; PMCID: PMC8347193.
- [9] K. Cho, W. Park, M. Hong, G. Park, W. Cho, J. Seo, and K. Han, "Analysis of latency performance of Bluetooth low energy (BLE) networks," *Sensors (Basel)*, vol. 15, no. 1, pp. 59-78, 2014. Doi: 10.3390/s150100059. PMID: 25545266; PMCID: PMC4327007.
- [10] Qualcomm S3 Gen 2 sound platform portfolio extended to deliver-b. Available: <https://www.qualcomm.com/news/releases/2023/06/qualcomm-s3-gen-2-sound-platform-portfolio-extended-to-deliver-b>
- [11] P. Popovski et al., "Wireless Access for Ultra-Reliable Low-Latency Communication: Principles and Building Blocks," in *IEEE Network*, vol. 32, no. 2, pp. 16-23, March-April 2018, doi: 10.1109/MNET.2018.1700258.
- [12] P. Popovski et al., "Wireless Access in Ultra-Reliable Low-Latency Communication (URLLC)," in *IEEE Transactions on Communications*, vol. 67, no. 8, pp. 5783-5801, Aug. 2019, doi: 10.1109/TCOMM.2019.2914652.
- [13] URLLC Latency Requirements in User and Control Planes. Available: <https://resources.pcb.cadence.com/blog/2022-urllc-latency-requirements-in-user-and-control-planes>
- [14] Control WirelessHART by HCF. Available: <https://www.emerson.com/documents/automation/white-paper-control-wirelesshart-by-hcf-en-42584.pdf>
- [15] N. Pleros, G. Kalfas, C. Mitsolidou, C. Vagionas, D. Tsiokos, and A. Miliou, "High-throughput and low-latency 60GHz small-cell network architectures over radio-over-fiber technologies," *Proc. SPIE 10128*, *Broadband Access Communication Technologies XI*, 101280I (28 January 2017). doi: 10.1117/12.2253022.
- [16] The Story of Ultra-Wideband Part 4: Short Latency is King. Available: <https://semiwiki.com/5g/283738-the-story-of-ultra-wideband-part-4-short-latency-is-king/>
- [17] F. Khan, S. Islam, J. Major, A. Usman, G. Moreno, and S. Narumanchi, "A Smart Silicon Carbide Power Module With Pulse Width Modulation Over Wi-Fi and Wireless Power Transfer-Enabled Gate Driver, Featuring Onboard State of Health Estimator and High-Voltage Scaling Capabilities," *2023 IEEE Applied Power Electronics Conference and Exposition (APEC)*, Orlando, FL, USA, 2023, pp. 386-391, doi: 10.1109/APEC43580.2023.10131317.
- [18] A guide to ultra-wideband frequency bands and range.
- [19] A Technology Comparison Adopting Ultra-Wideband for Memsen's file sharing and wireless marketing platform.
- [20] Getting Back to Basics with Ultra-Wideband (UWB).
- [21] M. K. Zadeh, R. Parseh, M. Molinas, and K. Kansanen, "Bifurcation in PWM converter-based systems with wireless communication-based current controller," *IEEE PES ISGT Europe 2013*, Lyngby, Denmark, 2013, pp. 1-5, doi: 10.1109/ISGTEurope.2013.6695458.
- [22] D. Beladjine, D. Boudana, A. Moualdia, and P. Wira, "Wireless Space Vector Pulse Width Modulation Control of Three-Phase Inverter Using RF-link," *2020 International Conference on Electrical, Communication, and Computer Engineering (ICECCE)*, Istanbul, Turkey, 2020, pp. 1-6, doi: 10.1109/ICECCE49384.2020.9179420.
- [23] S. K. Mazumder, M. Tahir, and S. L. Kamisetty, "Wireless PWM control of a parallel DC-DC buck converter," in *IEEE Transactions on Power Electronics*, vol. 20, no. 6, pp. 1280-1286, Nov. 2005, doi: 10.1109/TPEL.2005.857527.
- [24] S. K. Mazumder, K. Acharya, and C. M. Tan, "Design of an All-SiC Radio-frequency Controlled Parallel DC-DC Converter Unit," *2007 IEEE Power Electronics Specialists Conference*, Orlando, FL, USA, 2007, pp. 2833-2839, doi: 10.1109/PESC.2007.4342468.
- [25] Y. Tsutsumi, K. Akita, H. Kitagawa, K. Suzuki, R. Saito, and Y. Tawada, "High-Speed and Low-Latency Transmission by Millimeter-Wave Digital Wireless System for Si-IGBT/SiC-MOSFET Driver Control," *2022 International Power Electronics Conference (IPEC-Himeji 2022- ECCE Asia)*, Himeji, Japan, 2022, pp. 2275-2279, doi: 10.23919/IPEC-Himeji2022-ECCE53331.2022.9806967.
- [26] K. Yamamoto, F. Ichihara, K. Hasegawa, M. Tukuda, and I. Omura, "60 GHz wireless signal transmitting gate driver for IGBT," *2015 IEEE 27th International Symposium on Power Semiconductor Devices & IC's (ISPSD)*, Hong Kong, China, 2015, pp. 133-136, doi: 10.1109/ISPSD.2015.7123407.