

Biological H₂ Production from Synthesis Gas: Preliminary Techno-Economics & Reactor Design Issues



Summary

- Biomass-derived synthesis gas can provide a renewable route to hydrogen (H₂). A novel bacterial process has been proposed as an alternative to the conventional high-temperature catalytic process for the production of H₂ from synthesis gas via the Water-Gas Shift (WGS) reaction.
- We have performed a preliminary techno-economic analysis of the proposed process and of the conventional high-temperature shift (HTS) process. The biological WGS process may be a promising alternative to conventional processes at low methane concentrations because steam generation required for the conventional HTS and steam reforming can be eliminated, resulting in savings of both capital and operating costs.
- If steam reforming is necessary, the additional cost of the biological WGS reactor relative to the HTS reactor is not justified.

Wade Amos, Ed Wolfrum, Andy Watt
National Renewable Energy Laboratory
1617 Cole Boulevard, Golden, CO 80401 USA

Gasification

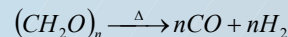

Water-Gas Shift (WGS)

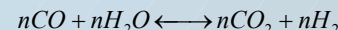

Overall

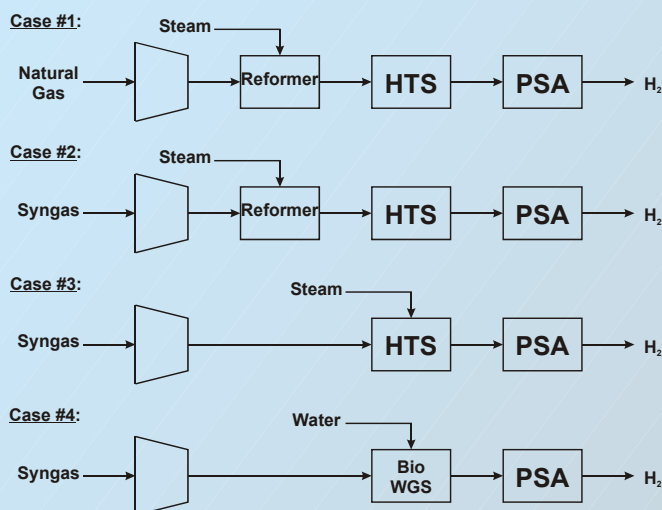
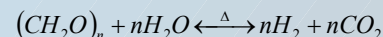

Discussion

- Four process cases were modeled. Case #1 was conventional steam-methane reforming (SMR) followed by high-temperature shift (HTS) conversion (the current industrial practice for hydrogen production). The next three cases involved the conversion of a synthesis gas stream containing equal concentrations of H₂, CO, and CO₂, along with a variable amount of CH₄ as a diluent. Case #2 reformed the syngas to convert CH₄ to CO followed by HTS. Case #3 was conversion of the syngas using HTS. Case #4 was conversion of the syngas using biological WGS.
- All four cases required compression of the inlet gas to 300psig and pressure-swing adsorption (PSA) for final gas cleanup.
- The results indicate that the biological WGS process is a promising alternative to conventional HTS process for CH₄ concentrations less than 5%, since steam generation needed for both reforming and HTS can be eliminated. The savings associated with this elimination is greater than the additional cost of the biological WGS reactors.
- At higher CH₄ concentrations, the reforming step is necessary because the additional hydrogen produced from CH₄ is significant. The additional cost of the biological WGS reactor relative to the HTS reactor is not justified.
- The cost of the delivered hydrogen is sensitive to the hydrogen production rate. At production rates less than 100 kg/hr, the contribution of labor costs to the required H₂ selling price is ~50%. At higher production rates, the feedstock cost becomes the main cost component

At higher CH₄ concentrations, reforming produces more H₂ per unit syngas

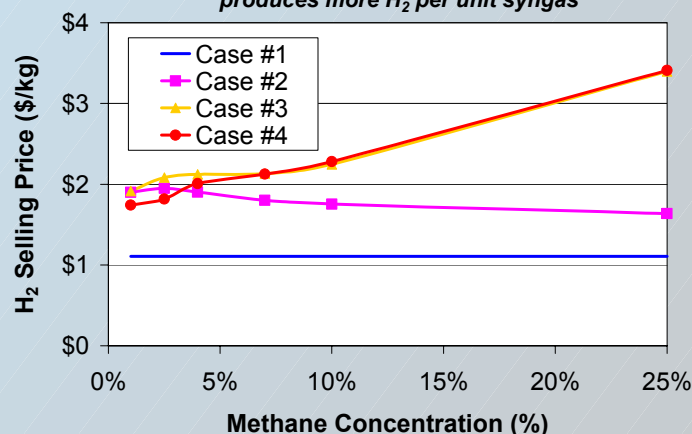

At lower production rates, labor costs control delivered H₂ prices

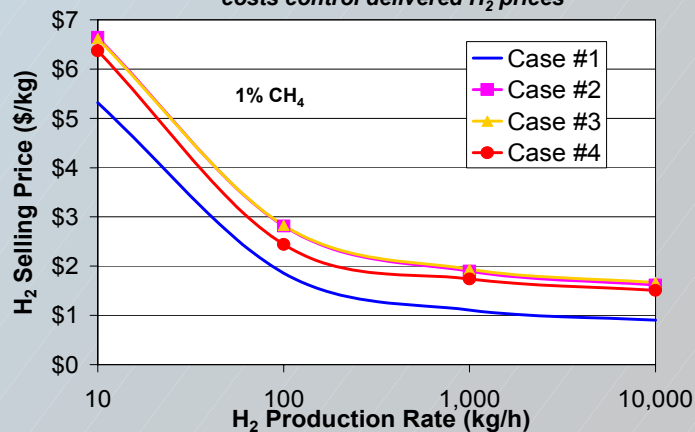

Key Model Assumptions

- Natural Gas: \$3.50/MMBtu
- Synthesis Gas: \$5.00/MMBtu
- Electricity: \$0.05/kWhr
- Capital: 15% WACC

Acknowledgments

The authors gratefully acknowledge Pin-Ching Maness of NREL for helpful discussions, and financial support from the Hydrogen, Fuel Cells, and Infrastructure Technologies Program of the EERE Office of the USDOE

