

SERI/TP-252-2331
UC Category: 64
DE85000504

Open-Cycle Ocean Thermal Energy Conversion (OTEC) Research: Progress Summary and a Design Study

T. Penney
D. Bharathan
J. Althof
B. Parsons

August 1984

To be presented at the ASME Winter Meeting
New Orleans, Louisiana
9 – 14 December 1984

Prepared under Task No. 4001.22
FTP No. 456-84

Solar Energy Research Institute

A Division of Midwest Research Institute

1617 Cole Boulevard
Golden, Colorado 80401

Prepared for the
U.S. Department of Energy
Contract No. DE-AC02-83CH10093

Printed in the United States of America
Available from:
National Technical Information Service
U.S. Department of Commerce
5285 Port Royal Road
Springfield, VA 22161
Price:
Microfiche A01
Printed Copy A02

NOTICE

This report was prepared as an account of work sponsored by the United States Government. Neither the United States nor the United States Department of Energy, nor any of their employees, nor any of their contractors, subcontractors, or their employees, makes any warranty, express or implied, or assumes any legal liability or responsibility for the accuracy, completeness or usefulness of any information, apparatus, product or process disclosed, or represents that its use would not infringe privately owned rights.

**OPEN-CYCLE OCEAN THERMAL ENERGY CONVERSION (OTEC) RESEARCH:
PROGRESS SUMMARY AND A DESIGN STUDY**

T. Penney*
D. Bharathan*
J. Althof*
B. Parsons

Solar Energy Research Institute
1617 Cole Blvd.
Golden, Colorado

*Member ASME

ABSTRACT

In 1980, the Westinghouse Corporation completed an extensive Claude open-cycle ocean thermal energy conversion (OC-OTEC) system design study. Since that time, the Solar Energy Research Institute (SERI) has produced concepts and data bases that have reduced the technical uncertainties associated with the evaporator and condenser design and performance, seawater sorption kinetics and gas removal systems, low pressure turbine design with novel materials, and low cost system containment and structural design. This paper describes an integrated system design case study using the improved data base and summarizes an assessment of the relative thermodynamic performance of advanced technologies, drawing parallels with Claude's early work in the 1930s. Projections from these latest advances imply that OC-OTEC systems can be cost effective in sizes less than 10 MW_e.

Analyzing the research needs for OC-OTEC systems reveals that an experimental facility integrating all essential components of a system is required. This paper describes a facility for conducting advanced research and verifying cycle feasibility in terms of performance, reliability, and cost. The thermodynamic performance of this integrated design is projected using an analytical system model incorporating the highly coupled component interactions.

BACKGROUND

Since the filing of Georges Claude's patent (1) on 17 June 1932, a rather limited set of open-cycle OTEC designs for basic components or total systems have been scrutinized. Most papers in the OTEC literature deal superficially with open-cycle systems, mainly focusing on closed-cycle systems. Some references consider open and the Claude cycle¹ synonymous, ignoring other important open-cycle options proposed by Beck (2) (steam lift pump), Ridgway (3,4) (mist lift), Zener (5) (foam lift), and others. Although somewhat outdated, OTEC

publications that present a well rounded and complete view of both open- and closed-cycle systems can be found in Cohen (6,7), Lavi (8), and Apte et al. (9).

In July 1983, the Department of Energy (DOE) completed an ocean energy technology assessment (10) and identified the unknowns in the various approaches. Specific issues related to heat and mass transfer in OC-OTEC are addressed in the 1983 overview paper by Bharathan et al. (11).

The reasons for pursuing closed- rather than open-cycle OTEC systems were, however, quite clear; industry was better equipped to deal with the problems of bio-fouling and corrosion of heat exchangers than to develop, for the Claude cycle system, an entirely new product line of large, low-pressure turbines and low-loss (e.g., liquid and vapor-side pressure drop) direct-contact heat exchangers of which little was known.

Problems generic to both cycles include ocean engineering questions of sea-state survivance and associated risks. The large capital investments needed to build an OTEC system drove policy makers to pursue a research and development path with lower technological risks so industry might begin to commercialize OTEC systems within the next decade.

With the foresight to keep the less advanced OTEC options in the long term horizon and to identify the issues needing resolution for a more definitive assessment, DOE commissioned the Westinghouse Corporation to complete an alternative OTEC power system study (12) to address the open cycle and hybrid power system options. Drawing upon work on OTEC in the 1970s by Boot and McGowan (13), Heronemus (14), Brown and Wechsler (15), Anderson (16), Zener (17), Watt et al. (18), and others, Westinghouse showed that an integrated OC-OTEC plant with a 100-MW_e net capacity could produce an acceptably low cost per kilowatt hour. In a later paper (19), Westinghouse indicated that a full-scale 100-MW_e plant presented somewhat of an impasse to reasonable development objectives in terms of cost, potential funding, and timing of its participation as a much needed energy resource. They hypothesized that the best approach would be to design and build a 2.5- to 3.0-MW, OC-OTEC plant to provide power and potable

¹The Claude open cycle is referred to in this paper as OC-OTEC, for convenience.

water to any one of several island communities that were largely dependent on imported fossil fuels. They further postulated that the plant would be designed for a 20- to 30-year life, and after extensive initial testing, it would be used as a commercial water and power production facility. Incurred plant cost would be recoverable during its commercial application phase. During the experimental phase, the plant could serve as the demonstration model to evaluate the availability/reliability criteria as required by regulations governing utility company acquisitions of unconventional power plants.

Consistent with that philosophy and in concert with the timing of the deployment (20) of the reconfigured OTEC-1 (21) 4-ft polyethylene cold water pipe at the Natural Energy Laboratory in Hawaii (NELH), SERI, assisted by Creare Research and Development, Inc. of Hanover, New Hampshire, Science Applications, Inc. of Hermosa Beach, Calif., and T. Y. Lin International of San Francisco, Calif., developed a small-scale (nominal 1 MW_e) preliminary conceptual design of a shore-based OC-OTEC research facility (22) that incorporated the latest developments on the heat exchangers (23-35) and other components.

There are several identified, unresolved issues related to large-scale OC-OTEC development. One of the primary issues that a research facility would help resolve is of the highly coupled nature of the open-cycle system. This coupling is the result of using steam produced from the warm resource water as the working fluid to drive the power generator and then condensing it directly on the cold resource water. Any changes in the resource temperature, tidal and wave fluctuations, or speed of the power train (turbine/generator) would cause a highly coupled interaction within the system, changing the operation and performance of the subcomponents. A research facility could also be used to:

- develop experimental data bases for validating design methods of large-scale direct contact heat exchangers
- investigate various subcomponent options including evaporators, condenser subsystems, and turbines
- evaluate turbine performances for dual-flow horizontal and vertical axis turbines
- investigate suitable composite structures for developing low-cost turbine rotor options
- evaluate structural material options for vacuum containment
- investigate interaction of sea states with the barometric heat exchangers
- evaluate the effects and extent of gas desorption from seawater in the various heat exchanger options
- investigate material and subcomponent degradation caused by seawater corrosion and biofouling.

A rather comprehensive list of open research issues related to OTEC development may be found in Ref. (10).

A fresh look at smaller size OC-OTEC systems for advancing the state of the art combined with advances through recent research establishes a greater potential for OC-OTEC systems sooner than previously anticipated. A few of the key technical aspects of our new conceptual design are discussed here and compared with Claude's early vision of his open-cycle plant.

CLAUDE'S PREDICTIONS AND WHAT WE KNOW TODAY

On 2 July 1935, the United States patent office granted Georges Claude and Paul Boucherot (1) patent number 2006985 in which they had 12 claims regarding

the process of converting ocean thermal gradients in a direct-contact open cycle method. Claude and Boucherot's ideas were explicit and detailed based upon their own experiments (36-41) conducted in earlier trials at Ougree, Belgium and Matanzas Bay, Cuba.

A recent systems analysis of the Claude open-cycle system was completed by Parsons et al. (42) and subsequently used to give design guidance for our small-scale conceptual OC-OTEC facility. We felt it would be worthwhile to compare Claude's projections with our model to identify research issues that complement or deviate from current knowledge and to reflect on unknowns in the feasibility of this power cycle conceptual design.

The statements by Claude and Boucherot in their patent contained details about evaporation, use of the vapor in the turbines, condensation of vapor, extraction of air from the degasifiers and the condenser, pumping of warm and cold seawater, and itemization of developed (gross) and absorbed (gross minus net) power. Using their quoted technical specifications for the categories cited in their patent, we were able to cross check and independently compare performance values, water flow rates, temperature distributions, noncondensable gas and facility leak rate assumptions, auxiliary motor efficiencies, water and steam side effectiveness for heat exchangers, head losses in the hydraulic circuits, pressure drops in the intercomponent passages and net-to-gross power ratios. Furthermore, we completed a short thermodynamic optimization study to evaluate how well Claude's predictions matched a design criterion for maximum net power (and hence minimal auxiliary losses).

Claude and Boucherot's concept for an integrated 50-MW_e (gross) OTEC plant is shown in Fig. 1 (taken from their patent filing). Warm seawater, entering via pipe No. 62, is partially deaerated by the traps in the upcomer, and is distributed to the evaporator by way of a slotted overhead water box. Low density steam is produced in the vacuum chamber and expanded through a set of turbines (84). A series of generators produce electricity with feedback loops (108,110,112) that control turbine speed and load. Cold water from the ocean depth is fed into a direct-contact condenser maintaining low pressure on the downstream side of the turbine. Pumps (82 and 102) are required to overcome the frictional head losses in the warm and cold circuits and maintain the water level in chamber 96 at the correct height. A vacuum exhaust system (104) removes noncondensable gases evolved from the feedstreams or leaked

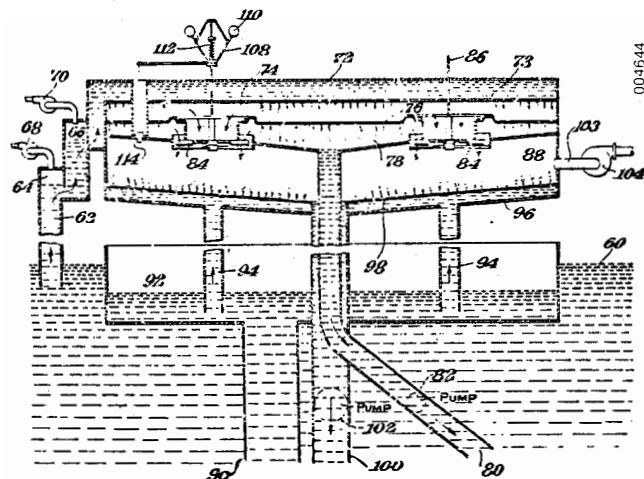

SOURCE: Claude and Boucherot (1)

Fig. 1. Claude's 50-MW_e Conceptual Open-Cycle Plant Design

from the atmosphere into the vacuum chambers and a small amount of uncondensed steam from the condenser.

The large-scale plant design is based on the results from their onshore experimental apparatus shown in Fig. 2. Here the incoming seawater follows a tortuous path to free dissolved noncondensable gases before entering the heat exchangers. Rather than distribute the warm seawater to the evaporator from above, as in the conceptual design, they chose a vertical spout (160) arrangement. After the steam expands through the turbine (166), it condenses in a three stage direct-contact condenser. The first two stages of the condenser are illustrated in Fig. 3. Cold seawater spills in a controlled manner onto the inside of a circular pipe forming a falling film (188,192). In the first stage the steam flows downward in a cocurrent fashion. The steam is then turned 180 degrees and passes through the second stage a countercurrent falling film section. Finally, the remaining uncondensed steam and inert gases enter the third-stage, a countercurrent packed column condenser shown in Fig. 2 as item 196.

The plant design parameters and performance listed by Claude and Boucherot in their patent are rather detailed, but we note that their calculations were limited to OTEC geographic locations with an average available resource temperature difference of 24°C (e.g., Guam, Manila) (43), 2°C higher than Cuba's resource. By using the available specific design parameters listed in Claude's patent as inputs to the computer program and by assuming and adjusting values of parameters not listed, we were able to closely match the conditions of their 50-MW_e design as shown in Table 1. Important outputs and results related to this comparison are discussed next.

Even before the 1940s when Leon Nisolle experimentally quantified the performance of various evaporator geometries (44,45), Claude recognized that efficient evaporation is easier to achieve than efficient condensation. This is demonstrated by his assumption of 100% evaporator effectiveness (very close to our fresh and seawater data with verified values of 90-98%) and his very conservative condenser design with its actual/minimum water flow ratio (minimum thermodynamic requirement) of 1.65 and a height of transfer unit (HTU) of 3.45 m. Current designs of direct-contact

condensers result in an actual/minimum water flow ratio of 1.2 and a HTU of 0.3 m.

Claude projected a rather low total-to-static efficiency of 0.71 for the performance of a single turbine in his 50-MW_e plant compared with today's improved technology capability with projections by Westinghouse of nearly 0.81. The eight turbines (nominally 6 MW_e gross each) in Claude's design are quite large (roughly 10 m in diameter) with rotational speeds of nominally 840 rpm and would require engineering and manufacturing development even today.

Claude's design includes passive degasification² of the seawater in the water supply upcomer to remove inert gases before the streams enter the heat exchangers. The pressure in the degasification chambers are held below atmospheric pressure, yet higher than the pressure required to flash (i.e., boil) the seawater. Possible benefits of degasification include less power required to remove the noncondensable gases (which are compressed from a higher pressure) and improved condenser performance due to a reduction of gas-side diffusional resistance.

The condenser exhaust system identified by Claude could handle all the noncondensable gases dissolved in the seawater (primarily nitrogen and oxygen) and an

²Recent reports of the 1980s by Hydronautics (46), ORNL (47), Westinghouse (12), Parsons, et al. (42), and Lewandowski et al. (48) indicated no significant benefit (in terms of cost and net power) results from active deaeration of the seawater. Most of these recent investigators had reason to believe that gas would not readily come out of solution without the additional seawater head imposed by the active deaeration systems (i.e., packed columns). Recently, Krock at the University of Hawaii under subcontract to SERI, communicated results (49) indicating dissolved gases readily desorb in the upcoming seawater supply pipes nearly independent of seawater flow rates at an exchange rate of twice that of fresh water data. This new result may warrant inclusion of passive seawater deaeration components (similar to Claude's ideas) in current OC-OTEC plant designs. Final confirmation of these data and the physical explanations of the phenomena will be reported in the near future.

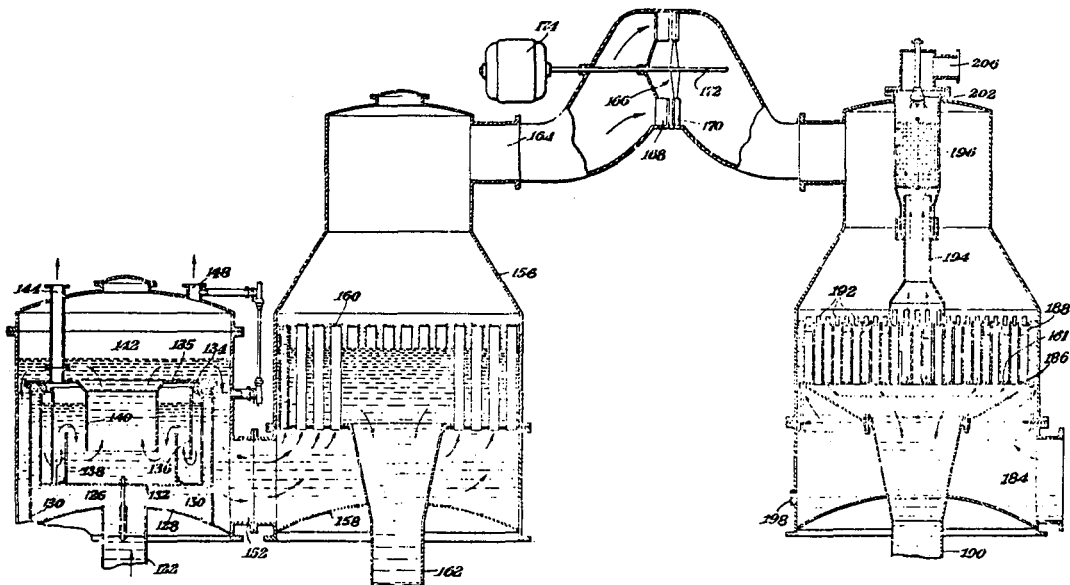

SOURCE: Claude and Boucherot (1)

Fig. 2. Claude's Experimental Apparatus

Table 1 - Comparison of Claude's Design Parameters and Simulated Computer Program Results

Component Description	Claude Design	Program Inputs	Program Results	Remarks
Evaporator				
warm water inlet temperature (°C)	29	29	-	fairly high warm water resource temperature, limited locations; actual evaporator effectiveness closer to 0.95 (30)
steam production temperature (°C)	26	-	26	
effectiveness	-	-	1.0	
warm seawater flow rate x 10 ⁻³ (kg/s)	142	-	143	
steam production rate (kg/s)	710	-	703	
Turbines				
steam inlet temperature (°C)	26	26	-	no evaporator-turbine vapor pressure loss is assumed; generator efficiency has not changed much since 1932; Westinghouse (12) used a turbine efficiency of 0.81; turbine diameter of up to 5 m possible with current technology (55).
steam outlet temperature (°C)	13.5	13.5	-	
generator efficiency	0.96	0.96	-	
gross power (MW _e)	50	50	-	
turbine total-to-static efficiency	-	0.71	-	
number of turbines	8	8	-	
turbine diameter (m)	-	-	9.7	
Condenser				
cold water inlet temperature (°C)	5	5	-	no turbine-condenser pressure loss or diffuser recovery is assumed; measurements in countercurrent condensers indicate low but nonnegligible pressure losses (56); actual-to-minimum flow ratio should be closer to 1.2.
cold water outlet temperature (°C)	10.5	-	10.5	
steam inlet temperature (°C)	13.5	-	13.5	
steam outlet temperature (°C)	6	6	-	
vapor pressure loss (atm)	0	0	-	
cold seawater flow rate x 10 ⁻³ (kg/s)	76.9	-	77.7	
actual/minimum flow rate	-	1.63	-	
Desorption				
gas removal pressures (atm)	0.06, 0.10	-	0.06, 0.10	five stage compression with intercooler used in simulation; Claude did not have adequate data to estimate dissolved gas in cold seawater or leakage through vacuum containment structure; simulation used a compressor efficiency of 0.8.
cold-side gas temperature (°C)	5	5	-	
warm-side gas temperature (°C)	29	29	-	
cold-side gas release (m ³ /s)	10	-	10.6 (max)	
warm-side gas release (m ³ /s)	30	-	20.5 (max)	
percentage of equilibrium gas released	-	100	-	
air leakage from the atmosphere	-	0	-	
cold-side compressor power (kW)	450	-	365	
warm-side compressor power (kW)	800	-	705	
Condenser exhaust				
volumetric flow of gas (m ³ /s)	145	-	143	three-stage compression with intercoolers was used with a compressor efficiency of 0.8.
gas inlet temperature (°C)	6	6	-	
NC gas release from seawater (kg/s)	-	-	0.70	
air leakage into heat exchangers (kg/s)	-	1.1	-	
compressor power (kW)	1000	-	1096	
Warm seawater flow loop				
total inlet and outlet pipe length (m)	-	1020	-	pipe length typical of land based plant; Claude used corrugated steel pipe in his experiments; water velocity in the intake pipe was matched to Claude's design values; largest existing commercial pipe diameter now is near 4 m.
pipe roughness (m)	-	0.0127	-	
seawater velocity in pipes (m/s)	-	1	-	
evaporator liquid head loss (m water)	-	-	0.95	
total liquid head loss (m water)	1.35	-	1.29	
combined pump and motor efficiency	0.75	0.79	-	
pump power (kW)	2500	-	2300	
pipe diameter (m)	-	-	13.4	
Cold seawater flow loop				
total inlet and outlet pipe length (m)	-	3370	-	Claude used 2-km-long pipe to obtain 8°C cold water; low intake velocity; large condenser head loss imply a rather inefficient contactor; the height of transfer unit was increased ten-fold above experimental results (56) to match Claude's head loss.
seawater velocity in pipes (m/s)	1	1	-	
pipe diameter (m)	10	-	9.8	
condenser head loss (m water)	-	-	4.3	
total head loss (m water)	5.8	-	5.2	
combined pump and motor efficiency	0.8	0.79	-	
pump power (kW)	5450	-	5040	

excess amount of gases caused by leakage. Using up-to-date data on dissolved gases in seawater (49,50), we found his design to have an additional capacity of 25% to account for atmospheric air leakage. Our estimates for leak rates using the guidance of Aerstin and Street (51) result in leak rates nearly equivalent to the rate of noncondensable gas evolution from the seawater. Using this as a conservative value, we anticipate handling about 50% more exhausted noncondensables than Claude foresaw. However, the relative amount of leakage with respect to the gas desorption rate is an unresolved issue still being debated among researchers today.

Claude was very concerned with his critics questioning his ideas that an open-cycle OTEC plant could be designed to produce a significant amount of net power (40). This preoccupation perhaps led him to design plants for low component power requirements illustrated by the large 10-m-diameter cold water pipe with an intake seawater velocity of only 1 m/s. From the standpoint of energy generated per total volume of water used, the ideal ratio of warm water to total water flow for an OTEC Rankine cycle is 0.5 (52). Claude used a value of 0.67. Economics will always favor more warm water usage. Today, we consider the single item of greatest risk and highest cost to be the

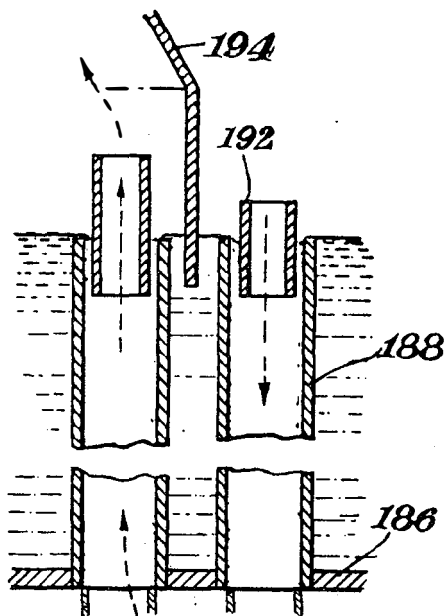

SOURCE: Claude and Baucherot (1)

Fig. 3. Claude's Two-Stage Direct-Contact Condenser Detail

cold water intake pipe. Reducing the diameter and increasing the allowable seawater velocity in the cold water pipe (which results in higher pumping power) are economic trade-offs well worth considering in modern designs. Claude also recognized the importance of the cold water pipe in the overall engineering evaluation as demonstrated by his two unsuccessful attempts to deploy a cold water pipe for his experimental apparatus in Cuba.

When he finally did succeed in laying a 2-km-long, 1.75-m-diameter pipe and operating the power cycle, the pipe was destroyed after only 11 days in rough seas.

Claude's calculations of the 50-MW_e gross design did not include the losses associated with vapor passages between the evaporator and turbine, between the turbine and condenser, and within the condenser itself. He, however, had a qualitative feel for their importance since his design has smooth vapor paths with few sharp bends. We find these pressure drops can be significant in the thermodynamic performance evaluations. In addition, current designs provide for a mist removal device between the evaporator and turbine to prevent salt droplet carry-over, which causes erosion and stress corrosion problems (purity of the fresh water by-product is a concern as well). These pressure losses, which detract from the useful work of the system, along with increased seawater intake velocities, result in a lower net-to-gross power ratio. A current 50-MW_e (gross) plant with seawater resource temperatures of 25°C and 5°C, accounting for vapor pressure drops and 2 m/s seawater intake velocities, would yield a net-to-gross ratio of around 75% (42). Claude's 50-MW_e plant calculations projected a net-to-gross ratio of 80%.

A NEW CONCEPTUAL DESIGN: SMALL-SCALE APPLICATIONS WITH INTEGRATED FLEXIBILITY

The SERI OTEC team, supported by its industrial and R&D subcontractors worked to combine the latest advances in OC-OTEC research to formulate and define a conceptual design of a small-scale (1 MW_e) facility. Component design guidance was initially provided by the systems analysis program of Ref. (42). Table 2 summarizes the

projected facility operating conditions. The important features of the design (22) are summarized below in terms of the major components, system integration, system analysis, instrumentation, and economics. Specifically, the effort resulted in a design with flow rates compatible with an existing but reconfigured 1.2-m-diameter cold water pipe using the thermal resource typical to Hawaii. Industry needs data at a scale that minimizes the uncertainty and therefore the investment risk. To design a prototype with this confidence level, we need actual seawater data at a scale that can be extrapolated within reason. Wherever possible, extrapolations using state-of-the-art component designs provided the technical data base for performance predictions. Given that caveat, our recent research on the OC-OTEC research facility leads us to some major conclusions described in the following subsections.

Components

Evaporators. Four potential evaporator geometries were reviewed; open channel flow (23,24,44,45), falling films (25,31,33), downward falling vertical jets (30-32,34,35), and upward flowing vertical spouts (26,30,44,45). Several criteria, required for an effective evaporator design, were defined as:

- Low liquid-side pressure loss
- Low vapor-side pressure loss
- Simple inlet and exit manifolds
- High effectiveness
- Small volume
- Low liquid entrainment
- Low gas desorption
- Low fabrication cost
- Low susceptibility to biofouling and corrosion.

Using analytical projections and experimental data, we evaluated the four contending evaporator geometries. A summary of the evaluation, shows that vertical spouts have more merits and fewer negative aspects [high liquid entrainment (53)] than the other geometries. Preliminary results with seawater on small scale (54) vertical spouts confirm fresh water test data obtained from full scale evaporators. Further testing on alternative components at a larger scale, at NELH, will provide final seawater test results for the comparison among contending evaporator geometries. Our last five years of research show that seawater evaporation can be done in evaporators with approximately half the volume and using less than 30% of the hydraulic seawater pumping power disclosed in the 1979 Westinghouse assessment (12).

Turbine. The turbine is perhaps the single most important component in the OC-OTEC system. The required large volumetric flow of steam coupled with the low amount of available specific energy results in turbine designs that are relatively large and expensive compared with conventional steam turbines. Small-scale OC-OTEC turbo-machinery (less than 5 MW_e) is within state-of-the-art capability because the rotor is similar to designs for the low-pressure stages of the conventional steam turbines. Costs of these units can be reduced by using composite materials (19), but several years of research and development effort is needed before they can be used.

A comparison of the last stage of a conventional power plant turbine and a turbine designed by the French for their conceptual OC-OTEC facility design for

Table 2. Nominal Design Conditions for the 1-MW_e Research Facility Design

Component Description			Component Description		
Turbine (double rotor)					
generated power	800.0	kW	cold seawater flow rate	1590.0	kg/s
generator efficiency	0.97	—	actual/minimum water flow rate	1.2	—
turbine efficiency	0.81	—	height of a transfer unit (HTU)	0.3	m
steam inlet temperature	20.0	°C	fraction of equilibrium		
steam outlet temperature	12.0	°C	gas release	0.8	—
steam inlet velocity	60.0	m/s	noncondensable gas evolution	0.028	kg/s
steam outlet velocity	97.5	m/s	air leakage rate	0.004	kg/s
steam enthalpy drop	65.5	kJ/kg	water loading	60.4	kg/m ² s
steam flow rate	14.7	kg/s	Condenser Exhaust Compressor Train		
maximum tip speed	450.0	m/s	number of compression stages	4.0	—
hub-to-tip ratio	0.44	—	intercooler pressure drop	276.0	Pa
outside diameter	2.8	m	compressor pressure ratio	3.1	—
rotational speed	3000.0	rpm	intercooler exit temperature	7.0	°C
Diffuser					
recovery factor	0.62	—	compressor efficiency	0.80	—
inlet steam speed	97.5	m/s	power requirement	75.9	kW
outlet steam velocity	60.0	m/s	Warm Seawater Flow System		
steam inlet temperature	12.0	°C	inlet + discharge pipe length	1120.0	m
steam outlet temperature	12.4	°C	seawater velocity in pipes	1.78	m/s
Evaporator					
mist removal pressure loss			number of 90° bends	10.0	—
coefficient	10.0	—	pipe diameter	1.22	m
mist removal steam velocity	30.0	m/s	pipe friction factor	0.0114	—
mist removal pressure drop	81.7	Pa	total inlet + discharge		
evap-mist pressure loss			pressure loss	23.45	kPa
coefficient	0.5	—	evaporator height	0.5	m
steam generation velocity	23.0	m/s	evaporator pressure loss	9.4	kPa
evap-mist pressure drop	2.4	Pa	density pressure loss	0.5	kPa
steam generation temperature	20.54	°C	total warm seawater pressure loss	33.4	kPa
evaporator effectiveness	0.95	—	combined pump-motor efficiency	0.786	—
warm seawater inlet temperature	25.0	°C	pump diameter	0.84	m
warm seawater outlet temperature	20.76	°C	pump speed	500.0	rpm
warm seawater flow rate	2130.0	kg/s	pump power requirement	88.4	kW
fraction of equilibrium			Cold Seawater Flow System		
gas release	0.9	—	inlet + discharge pipe length	3370.0	m
noncondensable gas evolution	0.034	kg/s	seawater velocity in pipes	1.33	m/s
air leakage rate	0.004	kg/s	number of 90° bends	10.0	—
spout seawater velocity	2.0	m/s	pipe diameter	1.22	m
evaporator planform area	35.2	m ²	pipe friction factor	0.0123	—
mist removal area	27.0	m ²	total inlet + discharge		
Direct Contact Condenser					
diff.-cond. pressure loss			pressure loss	34.2	kPa
coefficient	1.0	—	averaged condenser height	0.46	m
diff.-cond pressure loss	19.6	Pa	condenser pressure loss	8.7	kPa
cocurrent pressure loss	0.0	Pa	density pressure loss	4.2	kPa
countercurrent pressure loss	200.0	Pa	total cold seawater pressure loss	47.1	kPa
cold seawater inlet temperature	5.0	°C	combined pump-motor efficiency	0.786	—
cold seawater outlet temperature	10.6	°C	pump diameter	0.66	m
steam-gas outlet temperature	6.0	°C	pump speed	750.0	rpm
outlet steam flow rate	0.08	kg/s	pump power requirement	92.7	kW
System					
			total parasitic power requirement	257.0	kW
			net power production	543.0	kW

Tahiti is given in Table 3. The major difference in operating conditions is the inlet steam pressure, which is considerably higher for the conventional turbine. However, the pressure ratio of the conventional turbine is only about 50% higher than the OC-OTEC turbine. Because of a lower power density, which corresponds to lower pressure, the Tahiti design yields a gross power output of about 5 MW compared to 20-25 MW for the last stage of a conventional power plant turbine. Based on this comparison, existing turbine rotors are perhaps best suited for prototype designs to reduce risks. Because of the nature of their design, these are horizontal axis, double-ended turbines. Typical delivery times quoted by a reputable manufacturer for these conventional types of turbines adapted for OC-OTEC, are about two years with performance guarantees (55).

Condensers. The condenser research effort at SERI has primarily focused on direct-contact heat exchange. Direct-contact condensers are inherently more efficient than standard surface type exchangers because the temperature drop across the solid surface interface is eliminated. Without water production³ the proposed condenser configuration (based on criterion similar to that for the evaporator design) is a direct-contact cocurrent region followed by a direct-contact countercurrent final stage, somewhat similar to Claude and

³However, the production of potable fresh water from an OC-OTEC system requires a surface condenser or a water-to-water heat exchanger with a fresh water or nontoxic immiscible fluid direct-contact condenser.

Table 3. Comparison Between Conventional Last Stage and Tahiti OC-OTEC Turbine Conditions

Parameter	OC-OTEC	Last Stage
Inlet pressure (Pa)	2700	15,000
Exit pressure (Pa)	1100	4000
Isentropic enthalpy drop (kJ/kg)	120	200
Gross power (MW _e)	4-5*	20-25
Speed (rpm)	1500	1500
Tip diameter (m)	5.6	5.6

*Double pass turbine

Boucherot's design (1). Evaluation of various condenser geometries (56,57) indicates that this condenser subsystem is able to achieve low vapor-side pressure losses (<200 Pa) with water- and steam-side effectiveness of over 0.8 at low cost. Approach steam velocities to the cocurrent region, where 90% of the steam is condensed, should be about 20 m/s for a cost-effective subsystem design. This condenser configuration represents a significant improvement over Claude's designs requiring 25% less water flow and about an order of magnitude lower liquid-side pressure loss yet with a higher number of transfer units for the same height.

Noncondensable Exhaust Handling. The warm and cold seawater feed streams subjected to a reduction in pressure desorb dissolved noncondensable gases (primarily nitrogen and oxygen). These noncondensables along with any containment leaks must be continuously exhausted from the facility to maintain a low system pressure. Several options for gas exhaust systems were examined based on a conservative design point of 100% evolution of dissolved gases and an equivalent atmospheric air in-leakage. Calculations indicate that conventional designs for hardware using four to six centrifugal compressor stages with interstage coolers would limit losses to about 10% of system gross power output. Although not off-the-shelf equipment, centrifugal compressors are readily available from many manufacturers in the size range appropriate for this application. The operating conditions, however, would require redesigning components such as bearings and seals.

System Integration. An integrated 1-MW_e OC-OTEC facility is shown in Fig. 4. The entire vacuum enclosure and water feed and drain systems are integrated into a concrete cylindrical enclosure of 15-m diameter and 30 m height. The evaporator and condenser are located at their respective barometric levels. The turbine (horizontal axis, double pass) is located in the center directly above the evaporator. The top hatch of the enclosure allows easy access for installation and removal of the turbine and for inspection, maintenance, and repair. A round dome cover, although more conducive for vacuum vessels, was eliminated for cost reasons.

Warm seawater enters the vacuum enclosure through an inner annulus. Warm water effluent is drained through a central discharge pipe. Cold water enters through an outer annulus and is distributed to the direct-contact condensers located around the periphery. Cold water effluent like the warm water effluent discharges through a middle annular passage. Four separate pools directly underneath the enclosure separate

the water feed and discharge streams and provide for damping of water level fluctuations. The water columns in the intake and drain passages reduce the pressure difference the structure must withstand.

A surface condenser with a small fresh water production capacity of 0.63 kg/s is located outside the enclosure at ground level for easy access and maintenance as merits which were traded off against the additional pressure drops caused by steam routing obvious in this arrangement. The gas exhaust system, located at ground level, has obvious merits with no foreseen compromises.

Provisions are also made to deaerate the intake water passively in the upcomer as shown.

Degasification. The effect of evolved noncondensable gases on the evaporator and turbine performance is inconsequential. Evolution of noncondensables in the evaporator feed stream contributes to generation and reformation of the phase interface enhancing evaporation. However, at the evaporator saturation pressure, the noncondensable gases at a volume fraction of less than 0.3% are unlikely to have any major impact on surface renewal or liquid mixing. Noncondensables from the evaporator flow through the turbine and make a slight but negligible contribution to the power output.

The reduction in condenser effectiveness due to noncondensable gases and the accompanying increase in the condenser pressure strongly affects the turbine output by 10-15%. However, the trade-off in system parasitic power loss between degasification and no degasification shows only marginal improvements when active degasifiers (e.g., packed columns) are used. Research on passive barometric degasifiers (e.g., riser column direction changer) is in progress to quantify their potential for reducing the overall noncondensable exhaust pumping power.

Structure. For structural needs many new materials, such as petrochemical derivatives, polyethylene, vinyl, and carbon-based graphite epoxy were considered along with the more conventional building materials, such as steel, steel alloys, other metals, and various types of concrete. A comparison based on permeability, corrosion protection, leaching, and cost leads to concrete as the recommended choice for our small-scale OC-OTEC structural design (58). Several architectural options were examined, and a vertical cylinder was identified as the most cost effective. Test facility operation needs dictated that internal components such as evaporators, condensers, gas removal, and turbine areas remain accessible to allow for experimental changes. Construction of the relatively large vacuum vessel (15 m diameter x 30 m height) will use slip-form techniques to minimize construction joints. The construction materials and procedures are commonly applied techniques in the construction industry.

Flow Hydraulics. To obtain an understanding of liquid side losses and the associated pumping power requirements, calculations were performed to identify areas of significant loss contributions. The primary pressure loss occurring in the seawater inlet pipes is caused by friction and is proportional to the square of the seawater velocity. Aside from the inlet pipe loss, hydrostatic pressure losses dominate. The interactions associated with waves were found to be sufficiently damped by relatively small holding pools of about 10 m² planform area. Ocean dynamics associated with tides are of a quasisteady state nature due to the relatively long periods (12 hours and more) of tidal fluctuations. To achieve continuous system operation, flow must be maintained at low and high tide. We realize that the hydrostatic loss at low tide being a maximum is a primary design constraint.

Vapor Side Flow Analysis. Calculations were performed to evaluate the vapor passage losses. A typical pressure distribution through the system yields about 3% (40 Pa) across the mist removal device, 23% (315 Pa) for turbine losses, 62% (930 Pa) across the turbine for useful work, and 13% (200 Pa) across the condenser. This emphasizes the importance of maintaining low losses through the evaporator, condenser, and intercomponent passages to maximize the work out of the turbine.

System Analysis. A systems model with a series of subroutines that predict the performance of the various components or subsystems and an executive routine that integrates the appropriate input/output subroutine values to ensure system compatibility was developed to examine the thermodynamic performance of OC-OTEC systems (42). Thermodynamic optimization to minimize parasitic losses for the research facility results in turbine inlet and outlet temperatures of about 20°C and 11°C, respectively. For an inlet cold water pipe diameter of 1.2 m and length of 2750 m the net/gross power ratio and net power production as a function of cold water flow rate are shown in Fig. 5. This graph

indicates that if the cold water pipe is a dominate cost the best operating conditions would be that of maximum power output. This, of course, does not correspond to the best net/gross ratio (0.851) but rather a value of about 0.60 for this configuration. Overall system economic optimization, however, requires further consideration. Efforts are underway to combine the thermodynamic systems model with economic analysis to arrive at the best system designs based on various optimization criteria beyond the results presented below.

Instrumentation. Several basic measurements are required, including: flow rates (warm seawater, cold seawater, fresh potable water, effluent discharges); pressure (evaporator, condenser, turbine, exhaust system); temperature (warm seawater, cold seawater, evaporator vapor, turbine exhaust, condenser exhaust, exhaust system); dissolved gas content (warm seawater, cold seawater), and power (generator output, pumping power, exhaust power). Further instrumentation details may be found in Ref. (22).

All measurements are routine and within state-of-the-art techniques. The objective of the instrumen-

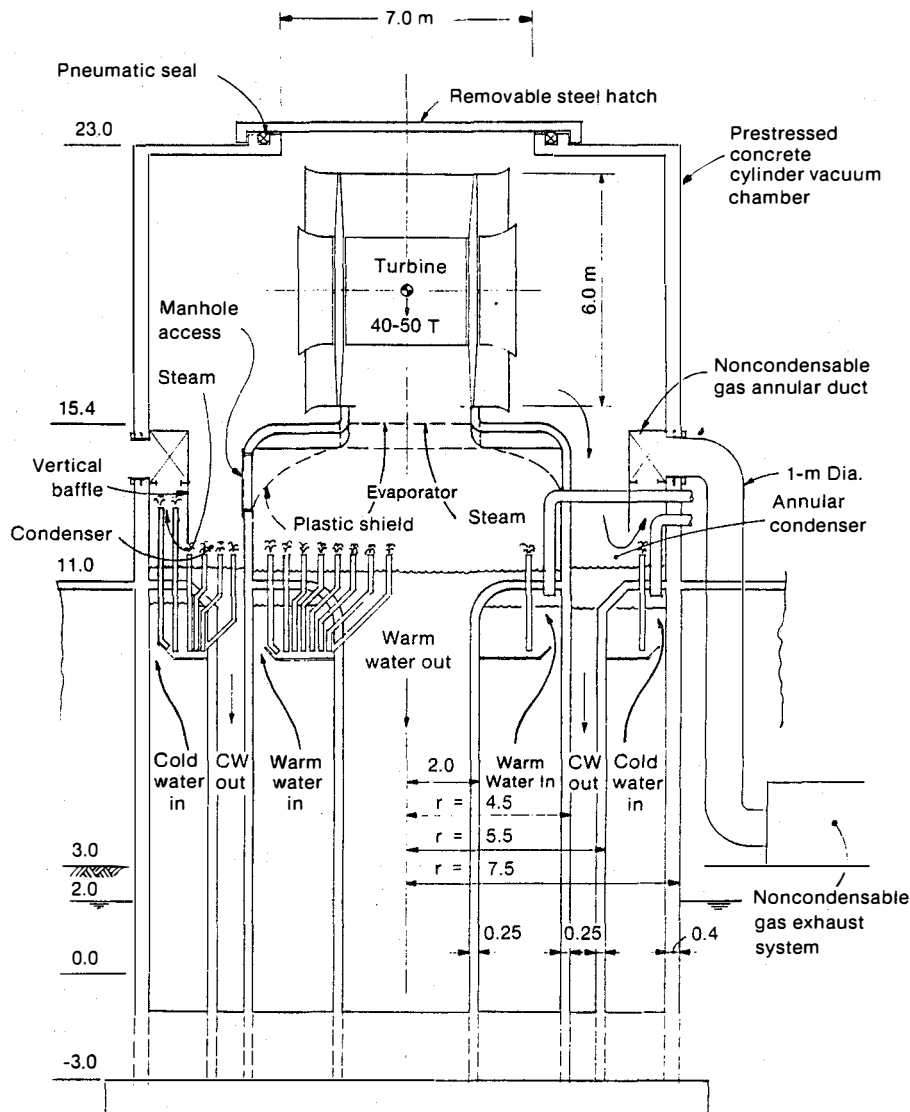

Fig. 4. Sectional View of the Integrated 1-MW_e Research Facility Design

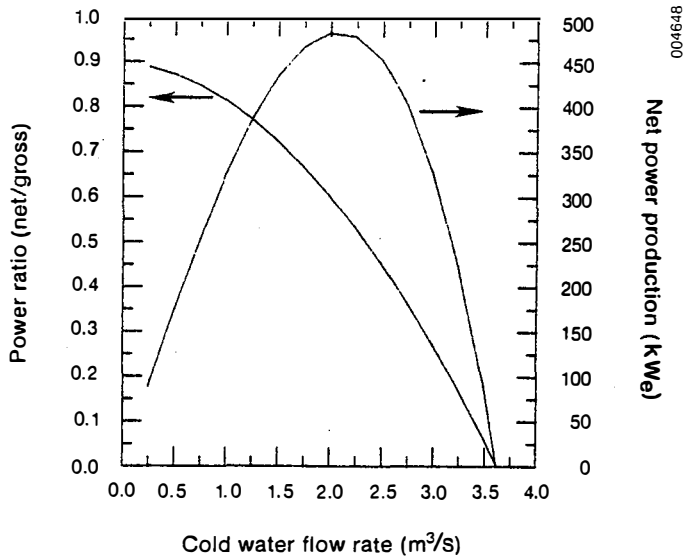

Fig. 5. Typical Variation of the Net-to-Gross Power Ratio and Net Power Output With Cold Water Flow Rate for a 1.2 m Diameter Inlet Pipe

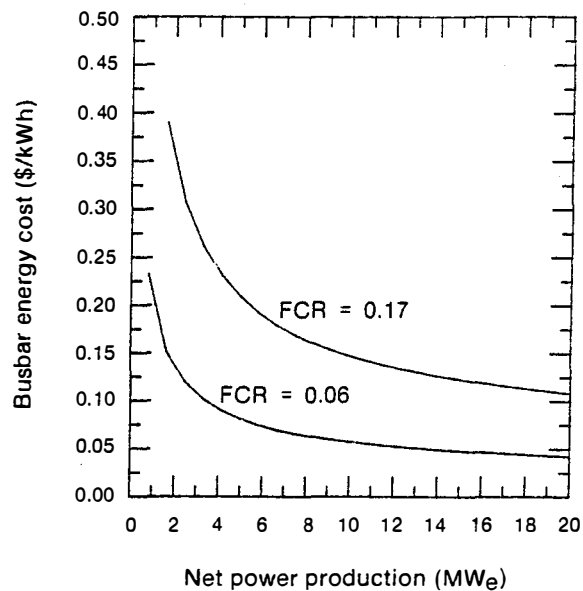

Fig. 6. Recommended Research Facility Instrumentation Requirements and Their Locations

tation is to provide researchers with data to evaluate the performance of various component options. Some of the measurements may also be used for monitoring, controlling, and optimizing overall facility operations.

Economics. Values solicited from various manufacturers and engineering projections show OC-OTEC plant capital investment costs ranging from off-the-shelf equipment at \$12/W to a projected improved cost of about \$3/W for routinely produced facilities at large scales (i.e., >20 MWe net). Fig. 6 shows our estimate of busbar energy cost as a function of net power production over the range of 1 to 20 MWe for two fixed charge rates (0.17 and 0.06). This energy cost is found by leveling the capital cost of the plant over its lifetime and accounting for return on investment, operation and maintenance, and actual operating time. Specifically, the amortization of plant capital cost is done using the fixed charge rate, an economic parameter defined by

$$FCR = \left\{ \sum_{n=0}^{N-1} \frac{[(1+i)^n]}{[(1+r)^n]} \right\}^{-1} \quad (1)$$

This parameter accounts for the escalation rate *i* the rate of return on investment *r*, and plant life *N*. For our study we have used fixed charge rates that give reasonable bounds for escalation and return on investment. (For an escalation of 8%, rate of return of 30%, and 30-year plant life the fixed charge rate is 0.17. For an escalation of 6%, rate of return of 10%, and a plant life of 30 years the fixed charge rate is 0.06). Further, we have assumed that the operation and maintenance costs are 1% of the total plant capital cost per year, the plant produces electricity 90% of the year (capacity factor of 0.9). The busbar energy cost can be defined as

$$BBEC = [(FCR \times K/CF) + OM \times K/CF]0.114$$

where BBEC = busbar energy cost, \$/kWh
 FCR = fixed charge rate, \$/\$-yr
 K = plant capital cost, \$/W
 CF = capacity factor
 OM = operation and maintenance factor
 0.114 = unit conversion constant (W-Yr to kW-h)

In addition, if certain components have projected life spans less than overall plant life, the energy cost must be proportionally increased to account for the added capital cost. It is clear that the economic parameters that are constantly changing from year to year must be carefully evaluated prior to assessing the overall economic feasibility of an OTEC plant.

Presently, the dominant costs of OC-OTEC plants are related to the seawater feed pipes (especially driven by length) and associated deployment and the vacuum containment structure. Recent research has reduced the heat exchanger costs to an extent where the cost is insignificant at the level of uncertainty in cost analysis (60).

FUTURE DIRECTIONS

Although this paper reemphasizes the Westinghouse conclusion that OC-OTEC is a technically feasible cost-effective renewable energy alternative today, further candidate areas of performance and cost improvements can be identified. Operation in seawater where unknown quantities of noncondensable gases may evolve must be quantified to design the appropriate heat exchanger size (direct contact or surface). Composite blading for the turbine can further improve the economics of the fixed capital investment costs. Instrumentation required to quantify component performance was described. The experimental data needs for OC-OTEC reveal that experimental facilities with a flow capability of only a few thousand gallons of seawater per minute could evaluate heat exchangers for modularly scalable units to sizes in excess of 5 MWe. Although the practicality of producing fresh water using surface condensers in an OC-OTEC plant is not new (61), achieving dual product outputs is important to improve the cost effectiveness of OTEC plants. Two recently completed analytical studies (62,63) have explored the commercial viability of this scheme. Both conclude a near-term potential for commercial viability of the OC-OTEC concept for production of fresh water and electricity at relatively small (<10 MW) sizes.

CONCLUSIONS

This paper has

- Assessed the impact of recent research results on the thermodynamic performance of a small-scale, shore-based OC-OTEC system
- Provided limited economic evaluations of key OC-OTEC components integrated into a design concept
- Identified issues that require further investigation to reduce the uncertainties in projected system performance.

Progress since the time of Claude has been slow, but, more recently, steady because of the facilities in the continental United States testing with fresh water (31,64), and in Hawaii (65), using warm and cold seawater from the ocean on a continuous basis. Efforts in these facilities have resolved a number of unknown issues and uncertainties in low-temperature direct-contact heat exchange.

Combining these technical results with the economical projections we can conclude that:

- Most of the economies of scale for an OC-OTEC plant can be realized for plants less than 10 MW_e in size
- Plants of 10 MW_e size can be built economically (within 20% of optimum estimates) using multiple state-of-the-art turbines and cold water pipes while using the new experimental data bases as the design strategy for cost-effective, direct-contact heat exchangers.
- There are significant commercial opportunities for 10-MW_e plants producing electricity and fresh water because of the cost reductions from dual product outputs
- The technological risks still appear to be high for OC-OTEC because of a lack of applicable seawater data at a scale amenable to extrapolation for commercial ventures.

An analysis of the research data needs for the next step of meaningful open-cycle OTEC development plan reveals that an experimental facility integrating all the essentials of a complete system is required. This design case study describes such a facility that could provide advanced research data and verify the cycle feasibility in terms of performance, cost, and reliability of key components and systems.

Acknowledgments

We would like to express our gratitude to Benjamin Shelpuk, manager of the SERI Oceans Program for providing guidance over the last five years of this research and to the U.S. Department of Energy, Ocean Energy Technology Division, for their financial support in carrying out this work. The technical contributions of the personnel involved in this work from Creare Research and Development, Inc., Science Applications, Inc., and T. Y. Lin are gratefully acknowledged. The assistance offered by the team at the Natural Energy Laboratory of Hawaii, Research Corporation University of Hawaii, and Hawaii Natural Energy Institute of the University of Hawaii is appreciated.

REFERENCES

- (1) Claude, G. and Boucherot, P., inventors Paris, France, "Method and Apparatus for Obtaining Power from Sea Water," U.S. Patent 3,006,985, 1935.
- (2) Beck, E. J., inventor Ventura, Calif., "Ocean Thermal Gradient Power Plant," U.S. Patent 3,967,449, 6 July 1976.
- (3) Ridgway, S. and Lee, C. K. B., "Installation and Operation of the Mist Lift Ocean Thermal Energy Conversion (OTEC) Process at Keahole Point Hawaii," Research and Development Associates, Inc., RDA-TRP126200-001, Marina Del Ray, CA, October 1983.
- (4) Ridgway, S. L., "The Mist Flow Ocean Thermal Energy Conversion Plant," Proceedings of the Fourth Ocean Thermal Energy Conversion Conference, New Orleans, LA, 1977.
- (5) Zener, C. and Fetkovich, J., "Foam Solar Sea Power Plant," Science, Vol. 189, 1975.
- (6) Cohen, R., "Electric Power Generation--Ocean Thermal Energy Conversion (OTEC)," Chapter 13, Solar Energy Handbook, Marcel Dekker, Inc.
- (7) Cohen, R. "Energy from the Ocean," Phil Trans. R. Soc. Land, A 307, pp. 405-437.
- (8) Lavi, A., Energy, The International Journal, Vol. 5, No. 6, Pergamon Press, New York, June 1980.
- (9) Apte, et al., "Ocean Thermal Energy Conversion Reference Manual," PRC #R-4017, PRC System Services, McLean, VA, August 1981.
- (10) "Ocean Energy Technology Assessment," Meridian Corporation, Falls Church, VA, July 1983.
- (11) Bharathan, D., Kreith, F., and Owens, W. L., "An Overview of Heat and Mass Transfer in Open Cycle OTEC Systems," SERI-TP-252-1854, Solar Energy Research Institute, Golden, CO, 1983.
- (12) "100 MWe OTEC Alternate Power Systems, Final Report," Westinghouse Electric Corporation, Power Generation Divisions, Lester, PA., March 1979.
- (13) Boot, J. L. and McGowan, J. G., "Feasibility Study of a 100 Megawatt Open Cycle Ocean Thermal Difference Power Plant," Report NSF/RANN/SE/GI-34979/TR/74/3, Mechanical Engineering Department, University of Massachusetts, Amherst, August 1974.
- (14) Heronemus, W. E., et al., "Technical and Economic Feasibility of the Ocean Thermal Differences Process," Third Quarterly Progress Report, NSF/RANN/SE/GT-34979/PR/74/3, University of Massachusetts, Amherst 1 December 1974.
- (15) Brown, C. E. and Wechsler, L., "Engineering an Open Cycle Power Plant for Extracting Solar Energy from the Sea," Offshore Technology Conference, OTC No. 2254, 1975.
- (16) Anderson, J. H. and Anderson, H., Jr., "A Summary of the Anderson and Anderson Analysis of the Sea Solar Power Process" 1964-1972," NSF/RANN/SE/GI-34979/TR/73/5, University of Massachusetts, Amherst, March 1973.
- (17) Zener, C., "Solar Sea Power," Physics Today, Vol. 26, No. 1, 1973, pp. 48-53.
- (18) Watt, A. D., Mathews, F. S., Hathaway, R. E., "Open Cycle Ocean Thermal Energy Conversion, A Preliminary Engineering Evaluation, Final Report," Colorado School of Mines, Golden, CO, 31 December 1977.
- (19) Coleman, W. H., Rogers, J. D., Thompson, D. F., Young, M. I., Westinghouse Electric Corporation, "Open

Cycle-OTEC Turbine Design," AIAA 2nd Terrestrial Energy Systems Conference, December 1981.

(20) Van Ryzin, J. C., "The Design and Development of a Deep Water Ocean Intake Pipeline for the Seacoast Test Facility in Hawaii," Third Arctic Engineering Symposium, New Orleans, LA, February 1984.

(21) Svensen, N. A., "An Overview of the OTEC-1 Design," Proceedings of the Sixth Ocean Thermal Energy Conversion Conference, G. L. Dugger, ed., Washington, DC, June 1979, pp. 5.3-1 through 5.3-15.

(22) Penney, T., Bharathan, D., Althof, J. and Parsons, B., "An Assessment of Technology for a Small-Scale Shore-Based Open-Cycle Ocean Thermal Energy Conversion System--A Design Case Study for an Integrated Research Facility," SERI/TR-252-2184, Solar Energy Research Institute, Golden, CO, forthcoming.

(23) Lior, N., and Gfreif, R., "Some Basic Observations on Heat Transfer and Evaporation in the Horizontal Flash Evaporator," Desalination, 33, pp. 269-286, 1980.

(24) Lior, N., and Purushothaman, V. M., "An Experimental Study of Flash Evaporation in Liquid Pools," Subcontract XM-9-8190-1, Solar Energy Research Institute, Golden, CO, May 1983.

(25) Wassel, A. T., Bugby, D. C., Mills, A. F. and Farr, J. L., Jr., "Design Methodology for Direct-Contact Falling Film Evaporators and Condensers for Open Cycle Ocean Energy Thermal Energy Conversion," SAI-083-83R-001, Science Applications, Inc., El Segundo, CA, February 1982.

(26) Ghiaasiaan, S. M., and Wassel, A. T., "Inverted Vertical Spout Evaporators for Open Cycle Ocean Thermal Energy Conversion," International Communications in Heat and Mass Transfer, Vol. 10, pp. 511-524, 1983.

(27) Kogan, A., Johnson, D. H., Green, H. J., Olson, D. A., "Open Cycle OTEC System with Falling Jet Evaporator and Condenser," Proceedings of the Seventh Ocean Energy Conference, Washington, DC, June 1980, pp. 16.4.1-9.

(28) Green, H. J., Olson, D. A., Bharathan, D., and Johnson, D. H., "Measured Performance of Falling Jet Flash Evaporators," SERI/TP-631-1270, Solar Energy Research Institute, Golden, CO, November 1982.

(29) Kreith, F., Olson, D. A., Bharathan, D., Green, H. J., "A Study of Falling Jet Flash Evaporators," SERI/TP-252-1415, Solar Energy Research Institute, Golden, CO., November 1982.

(30) Bharathan, D., Penney, T. R., "Flash Evaporation from Falling Turbulent Jets," SERI/TP-252-1853, Solar Energy Research Institute, Golden, CO, January 1983.

(31) Sam, R. G. and Patel, B. R., "Open Cycle Ocean Thermal Energy Conversion Evaporator/Condenser Test Program--Data Report," TN-340 Creare Research and Development, Inc., Hanover, NH, October 1982.

(32) Kim, S., "An Investigation of Heat and Mass Transport in Turbulent Liquid Jets," prepared for DOE/SERI under Grant No. DE-FG02-90CS89501, February 1983

(33) Hajiloo, M., "Experimental Investigation of Interfacial Shear in Downward, Two-Phase, Annular, Co-

Current Flow with Diameter Effects," prepared for DOE/SERI under Grant No. DE-FG02-80CS89501, February 1983.

(34) Ofer, S., "An Experimental Study of Evaporation from Round Turbulent Water Jets," prepared for DOE/SERI under Grant No. DE-FG02-80CS-89501, February 1983.

(35) Leininger, T. F., "Mass Transfer in Round Turbulent Water Jets," prepared for DOE/SERI under Grant No. DE-FG-02-80CS89501, February 1983.

(36) Claude, G. and Boucherot, P., "Sur l'Utilisation de l'Energie Thermique des Mers," Academie des Sciences, 22,25 November 1926, pp. 929-933, 1005-1006.

(37) Claude, G. "Utilization of the Heat Energy of the Sea," Academie des Sciences Comptes Rendus, V. 185, No. 19, Nov. 7 1927, pp. 987-990 (French).

(38) Bautaric, A., "Utilization of the Heat Energy of Oceans," Chaleur et Industrie, Vol. 9, No. 94, Feb. 1928, pp. 55-62 (French).

(39) Claude, G. and Boucherot, P., "On the Utilization of the Thermal Energy of the Seas," Academie des Sciences--Comptes Rendus, Vol. 186, No. 23, 4 June 1928, pp. 1491-1495 (French).

(40) Claude, G., "Power From the Tropical Seas," Mechanical Engineering, Vol. 52, No. 12, December 1930, pp. 1039-1044.

(41) Massart, G. L., "The Tribulations of Trying to Harness Thermal Power," Marine Technology Society Journal, Vol. 8, No. 9, October-November 1974, pp. 18-21.

(42) Parsons, B., Bharathan, D., Althof, J., "Thermodynamic Systems Analysis of Open-Cycle Ocean Thermal Energy Conversion (OTEC)," SERI/TR-252-2234, Solar Energy Research Institute, Golden, CO, forthcoming.

(43) "Large-Scale Distribution of OTEC Thermal Resource," map by Ocean Data Systems, Inc., 1978.

(44) Nisolle, L., "Rapport Sur Les Essais d'auto Evaporation," Professeur a l'Ecole Centrale des Arts et Manufactures, presented to Commission Technique de l'energie Thermique des Mers (in French), n.d.

(45) Nisolle, L., "Utilisation de l' Energie Thermique des Mers--les Problemes de Fonctionnement," Societe des Ingenieurs Civils de France, Paris, 1947.

(46) Lindenmuth, W., Liu, H., and Poquette, G., "Sea-water Degasification in OC-OTEC Risers," 8031-1, Hydronautics, Inc., Laurel, MD, March 1982.

(47) Golshani, A. and Chen, F. C., "Ocean Thermal Energy Conversion Gas Desorption Studies, Vol. 2, Degasification in a Packed Column and a Barometric Intake System," ORNL/TM-7438/V2, Oak Ridge National Laboratory, Oak Ridge, TN, September 1981.

(48) Lewandowski, A. A., Olson, D. A., and Johnson, D. H., "Open-Cycle OTEC Systems Performance Analysis," SERI/TR-631-692, Solar Energy Research Institute, Golden, CO, 1980.

(49) Krock, H., Zapka, M., Noncondensable Gas Exchange in the OC-OTEC Process--Experimental Seawater Results

at NELH, Report 57, J.K.K. Look Laboratory, University of Hawaii, Honolulu, Aug. 1984.

(50) Krock, H. J., "Gas Analyses of Water Samples for OTEC Program," No. 15, Honolulu, Hawaii, University of Hawaii, Department of Ocean Engineering, 1981.

(51) Aerstin, F. and Street, G., Applied Chemical Process Design, 1978 Plenum Press, New York.

(52) Johnson, D. H., "The Exergy of the Ocean Thermal Resource and Analysis of Second-Law Effeciencies of Idealized Ocean Thermal Energy Conversion Power Cycles," Energy, Vol. 8, No. 12, pp. 927-946, also SERI/TR-252-1420, Solar Energy Research Institute 1983.

(53) Bharathan, D. and Penney, T. R., "Mist Eliminators for Water Production from Open-Cycle OTEC Systems," SERI/TP-252-1991, Solar Energy Research Institute, Golden, CO, 1983.

(54) Larson-Basse, J., "Open-Cycle Ocean Thermal Energy Conversion Experiment," Solar Energy Research Institute, Golden, CO, August 1983.

(55) Penney T., Letter Report on Rateau Turbines from A. T. Wassel, Science Applications, Inc., Hermosa Beach, CA., 14 July 1983.

(56) Bharathan, D. and Althof, J., "An Experimental Study of Steam Condensation on Water in Countercurrent Flow in the Presence of Inert Gases," paper to be presented at ASME-WAM, New Orleans, LA., 1984.

(57) Ocean Research Group, interim data report on direct-contact countercurrent condenser tests conducted at SERI during FY 1983, Solar Energy Research Institute, Golden, CO, 30 September 1983.

(58) Ludke, R. P. and Chow, P. Y., "Structural Aspects of an Advanced Research Open Cycle OTEC Facility," Proceedings of the Third Offshore Mechanics and Arctic Engineering Symposium, Vol. 2, February 1984.

(59) Stoler, P., "Pulling the Nuclear Plug," Time, 13 February 1984, pp. 34-42.

(60) Parsons, B., Letter Report from Javier Valenzuela, Creare Research and Development, Inc., Hanover, NH, 17 May 1984.

(61) Nizery, A., Utilization of the Thermal Potential of the Sea for the Production of Power and Fresh Water, Institute of Engineering Research, University of California, Berkeley, CA., March 1954.

(62) Westinghouse Electric Corporation, A Study to Determine the Commercialization Potential of Open Cycle OTEC Water Plants, prepared for Maritime Administration, PB80-199060, NTIS, July 1980.

(63) "Preliminary OTEC Study Completed," The Solar Collector Vol. 9, No. 2, Spring 1984.

(64) "An Overview of SERI Solar Thermal Research Facilities," SERI/SP-631-760, Solar Energy Research Institute, Golden, CO, 1981.

(65) Hawaii Natural Energy Institute Annual Report, July 1982--June 1983, University of Hawaii at Manoa, Honolulu, HA.