

363
5-12-87
Jab

1

Dr. 2634
R-4277

SERI/TR-632-783

March 198

Design Considerations for Solar Industrial Process Heat Systems

MASTER

Nontracking and Line Focus Collector Technologies

Charles F. Kutscher
Editor



SERI

Solar Energy Research Institute

A Division of Midwest Research Institute

1617 Cole Boulevard
Golden, Colorado 80401

Operated for the
U.S. Department of Energy
under Contract No. EG-77-C-01-4042

DISTRIBUTION OF THIS DOCUMENT IS UNLIMITED

DISCLAIMER

This report was prepared as an account of work sponsored by an agency of the United States Government. Neither the United States Government nor any agency Thereof, nor any of their employees, makes any warranty, express or implied, or assumes any legal liability or responsibility for the accuracy, completeness, or usefulness of any information, apparatus, product, or process disclosed, or represents that its use would not infringe privately owned rights. Reference herein to any specific commercial product, process, or service by trade name, trademark, manufacturer, or otherwise does not necessarily constitute or imply its endorsement, recommendation, or favoring by the United States Government or any agency thereof. The views and opinions of authors expressed herein do not necessarily state or reflect those of the United States Government or any agency thereof.

DISCLAIMER

Portions of this document may be illegible in electronic image products. Images are produced from the best available original document.

Printed in the United States of America
Available from:
National Technical Information Service
U.S. Department of Commerce
5285 Port Royal Road
Springfield, VA 22161
Price:

Microfiche \$3.00

Printed Copy \$ 5.25

NOTICE

This report was prepared as an account of work sponsored by the United States Government. Neither the United States nor the United States Department of Energy, nor any of their employees, nor any of their contractors, subcontractors, or their employees, makes any warranty, express or implied, or assumes any legal liability or responsibility for the accuracy, completeness or usefulness of any information, apparatus, product or process disclosed, or represents that its use would not infringe privately owned rights.

SERI/TR-632-783
UC CATEGORY: UC-59b,62

DESIGN CONSIDERATIONS FOR SOLAR
INDUSTRIAL PROCESS HEAT SYSTEMS

NONTRACKING AND LINE FOCUS
COLLECTOR TECHNOLOGIES

CHARLES F. KUTSCHER
EDITOR

MARCH 1981

DISCLAIMER

This book was prepared as an account of work sponsored by an agency of the United States Government. Neither the United States Government nor any agency thereof, nor any of their employees, makes any warranty, express or implied, or assumes any legal liability or responsibility for the accuracy, completeness, or usefulness of any information, apparatus, product, or process disclosed, or represents that its use would not infringe privately owned rights. Reference herein to any specific commercial product, process, or service by trade name, trademark, manufacturer, or otherwise, does not necessarily constitute or imply its endorsement, recommendation, or favoring by the United States Government or any agency thereof. The views and opinions of authors expressed herein do not necessarily state or reflect those of the United States Government or any agency thereof.

PREPARED UNDER TASK NO. 1011.00

Solar Energy Research Institute

A Division of Midwest Research Institute

1617 Cole Boulevard
Golden, Colorado 80401

Prepared for the
U.S. Department of Energy
Contract No. EG-77-C-01-4042

DISTRIBUTION OF THIS DOCUMENT IS UNLIMITED

EB

THIS PAGE
WAS INTENTIONALLY
LEFT BLANK

PREFACE

During conceptual design reviews for the U.S. Department of Energy (DOE)-funded industrial process heat (IPH) field tests, the need became apparent for a document that would make designers aware from the outset of what issues should be considered. Such a document would have to make use of what had been learned to date and incorporate input from those experienced in the solar IPH design field.

Accordingly, in February 1980 the Solar Energy Research Institute (SERI) prepared a detailed design questionnaire and mailed it to DOE technical advisors and a number of previous IPH field test contractors. Results of the questionnaire were compiled by subject category, and a draft document was completed in June 1980. The draft was sent out for review, and a meeting was held at SERI on 31 July and 1 August 1980 to mold a final document. The following people were in attendance:

Kenneth Bergeron	Sandia National Laboratories, Albuquerque
James Castle	Solar Energy Research Institute
Roger Davenport	Solar Energy Research Institute
Jerry Greyerbiehl	U.S. Department of Energy Headquarters, Washington D.C.
Charles Kutscher	Solar Energy Research Institute
James Leonard	Sandia National Laboratories, Albuquerque
William Marlatt	Energy Technology Engineering Center
E. Kenneth May	Solar Energy Research Institute
Edward McBride	Science Applications, Inc.
Paul McCormick	Lockheed Missiles & Space Co.
William Nettleton	U.S. Department of Energy, San Francisco Operations Office

The editor gratefully acknowledges the time and energy contributed by these individuals, as well as the contributions of others who returned the original questionnaires. However, the editor assumes sole responsibility for the contents of this final document.

The editor would like to express a special thanks to Roger Davenport who, in addition to his contributions to the main body of the report, prepared the diagrams and glossary and attended to many of the minute details necessary in getting this document published.

Approved for

SOLAR ENERGY RESEARCH INSTITUTE



D. W. Kearney, Manager
Solar Thermal, Ocean and Wind Division

SUMMARY

Objective:

Since 1977 the U.S. Department of Energy (DOE) has funded a series of solar industrial process heat field tests. A great deal has been learned from the design and operation of these projects, and this document's purpose is to utilize this information in aiding designers of new systems.

Discussion:

This document lists items that should be considered in each aspect of the design of a solar industrial process heat system. The collector technologies covered are flat-plate, evacuated tube, and line focus, since these systems have been employed to date in the DOE field test program. This document should be highly informative to the designer lacking solar system experience, since a glossary of technical terms used in the report is included. This document is also a useful checklist for experienced solar system designers.

Since the application of solar energy to industrial thermal processes is still a rapidly evolving technology, this document stresses qualitative design considerations rather than specific design recommendations. The design engineer utilizing this report can avoid many of the problems that have occurred in previous projects, although detailed calculations will still be needed to ensure a successful system. However, to aid this effort, an appendix listing further sources of information is included in the report.

Conclusions and Recommendations:

Many of the problems experienced in the solar industrial process heat field test program occurred in earlier government programs that demonstrated the use of solar energy to supply domestic hot water, space heating, and cooling for buildings.

These problems included freeze damage of a heat exchanger due to thermosiphon heat loss in a collector loop and breakage of evacuated tube collectors due to thermal shock. The design considerations presented in this document should help prevent these mistakes in the future. Solar industrial process heat systems also have unique design problems, such as industrial effluents and overnight piping losses, and these are discussed as well.

THIS PAGE
WAS INTENTIONALLY
LEFT BLANK

TABLE OF CONTENTS

	<u>Page</u>
1.0 Introduction	1
2.0 Application.....	5
2.1 Suitability Assessment	5
2.2 Process Location	5
2.3 Process Temperature and Schedule	5
2.4 Process Type	7
3.0 Overall System Design Tradeoffs	9
3.1 Sizing and Configuration	9
3.2 Storage	11
3.3 Heat Transfer Fluids.....	11
4.0 Collectors.....	13
4.1 Selection.....	13
4.2 Location	14
4.3 Mounting, Orientation, and Tilt	15
4.4 Maintenance.....	15
5.0 Piping and Mechanical Subsystems	17
5.1 Piping and Insulation.....	17
5.2 Pumps and Fans	19
5.3 Valves and Dampers	20
5.4 Heat Exchangers	20
5.5 Storage	20
5.6 Maintenance.....	21
6.0 Instrumentation and Controls	23
6.1 Normal Operating Modes	23
6.2 Start-up/Shutdown	23
6.3 Freeze/Stagnation Protection	23
6.4 Emergency Conditions	24
6.5 Operator Training/Displays	24
6.6 Equipment	25
7.0 Installation and Start-up	27
7.1 Construction	27
7.2 Checkout/Commissioning.....	28

TABLE OF CONTENTS (concluded)

	<u>Page</u>
8.0 Energy Delivery Prediction	29
8.1 Irradiation Data.....	29
8.2 Collector Efficiency	29
8.3 Thermal Losses	30
8.4 Parasitic Energy	30
8.5 Overall System Performance.....	30
9.0 Economics	31
10.0 Data Acquisition	33
11.0 Safety	35
11.1 Hardware	35
11.2 Procedures	35
12.0 Environmental Issues	37
13.0 Documentation	39
13.1 Drawings.....	39
13.2 Documents	39
14.0 References	41
Appendix A: Sources of Information	43
Appendix B: Glossary.....	47

LIST OF FIGURES

		<u>Page</u>
3-1	Steam Flash System	10
3-2	Unfired Boiler Steam System	10
5-1	Direct-Return and Reverse-Return Piping Systems.....	17
5-2	Bellows and Expansion Loops for Thermal Expansion	19
B-1	Closed Loop System Configuration for Heating Water	49
B-2	Example of a Double-Walled Heat Exchanger.....	50
B-3	Typical Drain-Down System	50
B-4	Concentric Glass Evacuated Tube Collector.....	53
B-5	Flat-Plate Collector (Liquid Type).....	53
B-6	Open Loop System Configuration for Heating Water.....	54
B-7	Parabolic Trough Collector	54

LIST OF TABLES

1-1	Cycle 1: Low-Temperature Hot Water/Hot Air Industrial Process Heat Field Tests (60°-100° C, 140°-212° F).....	2
1-2	Cycle 2: Low-Temperature Steam Industrial Process Heat Field Tests (100°-177° C, 212°-350° F).....	2
1-3	Cycle 3: Intermediate-Temperature Steam Industrial Process Heat Field Tests (177°-288° C, 350°-550° F).....	3
1-4	Low-Temperature Cost-Shared Industrial Process Heat Field Tests (to 100° C, 212° F)	3
1-5	Cycle 4: Intermediate-Temperature Cost-Shared Industrial Process Heat Field Tests (100°-288° C, 212°-550° F).....	4
1-6	"Repowering" Industrial Retrofit Field Tests (Central Receivers)	4
1-7	Solar-Enhanced Oil Recovery Field Tests	4
2-1	Factors Favoring the Application of Solar Industrial Process Heat Systems	6

SECTION 1.0

INTRODUCTION

In 1977 the U.S. Department of Energy (DOE) began funding a series of solar industrial process heat field tests. A list of these projects is given in Tables 1-1 to 1-7. The purpose of this document is to supply designers with the benefits of lessons learned from these projects.

The temperatures covered to date by the field tests have been in the range of 55°-260° C (130°-500° F). Collectors employed have included flat plates, evacuated tubes, and various linear concentrators. Thus, this report does not cover the design of systems employing point focus receivers, central receivers, or solar ponds.

The reader should note that this document is not intended to provide a step-by-step design procedure. Rather, the purpose here is to suggest what alternative approaches should be considered, and how obvious past mistakes can be avoided. The points listed in this document should be considered carefully by the designer. However, at this early stage of the technology, many of the issues are not yet fully resolved, and a great deal of opportunity still exists for innovative design. A successful design effort will include a combination of detailed analysis and engineering judgment.

Finally, it must be emphasized that the design of a solar thermal system is a synergistic process involving the interaction of a large number of variables. Any statement regarding a particular aspect of the design cannot stand apart from other design considerations. Thus, all points made in this document must be considered in the context of the entire design framework.

**Table 1-1. CYCLE 1: LOW-TEMPERATURE HOT WATER/HOT AIR INDUSTRIAL
PROCESS HEAT FIELD TESTS (60°-100° C, 140°-212° F)**

Location	Process	Industrial Partner/ Contractor	Collectors	Array Size (m ²)	Collection Temp. (°C)	Designed Annual Energy Delivery (GJ/m ²)	Status
HOT WATER							
Sacramento, Calif.	Soup can washing	Campbell Soup Co./ Acuron Corp.	Flat plate and parabolic trough	681.4	66	3.41	Operational (Nov. 1977)
Wilmington, S.C.	Textile dyeing	Riegel Textile Corp./ General Electric Co.	Evacuated tube	620.6	132	2.38	Operational (June 1978)
Harrisburg, Pa.	Concrete block curing	York Building Products, Inc./ AAI Corp.	Multiple reflector	856.2	57	1.85	Operational (Sept. 1978)
HOT AIR							
Gilroy, Calif.	Onion drying	Gilroy Foods, Inc./ Trident Engr. Assoc.	Evacuated tube	552.8	99	4.46	Operational (Sept. 1979)
Decatur, Ala.	Soybean drying	Gold Kist, Inc./ Teledyne-Brown Engr.	Flat plate	1,217.4	60	3.20	Operational (May 1978)
Canton, Miss.	Kiln drying of lumber	J. A. LaCour Kiln Services, Inc./ Lockheed Missiles and Space Co.	Flat plate	234.1*	61	4.05	Operational (Nov. 1977)
Fresno, Calif.	Fruit drying	Lamanuzzi & Pantaleo Foods/ Calif. Polytechnic State U., San Luis Obispo	Flat plate	1,951.0	63	1.25	Operational (Aug. 1978)

*plus 223 m² reflectors

**Table 1-2. CYCLE 2: LOW-TEMPERATURE STEAM INDUSTRIAL PROCESS
HEAT FIELD TESTS (100°-177° C, 212°-350° F)**

Location	Process	Industrial Partner/ Contractor	Collectors	Array Size (m ²)	Steam Conditions	Designed Annual Energy Delivery (GJ/m ²)	Status
Pasadena, Calif.	Commercial laundry	Home Cleaning and Laundry/ Jacobs-Del Solar Systems	Parabolic trough	603.5	0.86 MPa 171° C	2.83	Construction
Sherman, Tex.	Gauze bleaching	Johnson & Johnson/ Aourex Corp.	Parabolic trough	1,070.2	0.86 MPa 174° C	1.39	Operational (Jan. 1980)
Bradenton, Fla.	Orange juice pasteurizing	Tropicana Products, Inc./ General Electric Co.	Evacuated tube	929.0	1.03 MPa 177° C	3.07	Construction
Fairfax, Ala.	Fabric drying	West Point Pepperell/ Honeywell, Inc.	Parabolic trough	772.3	0.58 MPa 158° C	1.50	Currently being refurbished

**Table 1-3. CYCLE 3: INTERMEDIATE-TEMPERATURE STEAM INDUSTRIAL
PROCESS HEAT FIELD TESTS (177°-288° C, 350°-550° F)**

Location	Process	Industrial Partner/ Contractor	Collectors	Array Size (m ²)	Steam Conditions	Designed Annual Energy Delivery (GJ/m ²)	Status
Dalton, Ga.	Latex production	Dow Chemical/ Foster-Wheeler Devlp. Corp.	Parabolic trough	922.5	186° C 1.14 MPa	2.86	Construction
San Antonio, Tex.	Brewery	Lone Star Brewing Co./ Southwest Research Inst.	Parabolic trough	877.9	177° C 0.96 MPa	3.84*	Construction
Ontario, Ore.	Potato processing	Ore-Ida Co./ TRW	Parabolic trough	884.4	214° C 2.07 MPa	2.27	Construction
Hobbs, N. Mex.	Oil refinery	Southern Union Co./ Monument Solar Corp.	Parabolic trough	936.5	193° C 1.27 MPa	3.99	Construction

*collector output

**Table 1-4. LOW-TEMPERATURE COST-SHARED INDUSTRIAL
PROCESS HEAT FIELD TESTS (to 100° C, 212° F)**

Location	Process	Collectors	Contracting Team	Array Size (ft ²)	Delivery Temp. (° C)	Designed Annual Energy Delivery (GJ/m ²)	Status
Santa Isabel, Puerto Rico	Fruit juice and nectar pasteurization	Evacuated tube	Nestle Enterprises/ General Electric/ CEER/OMB A/E	4,645	99	2.01	Design
Santa Cruz, Calif.	Leather tanning and finishing	Flat plate	Salz Leathers/ Pacific Sun/ Chilton Engr.	3,666	27	2.58	Design
Oxnard, Calif.	Sodium alginate processing	Flat plate	Stauffer Chemical/ Wormster Scientific/ Desert Research Inst.	3,530*	52	7.44	Design
Des Moines, Iowa	Meat processing	Flat plate	Team, Inc. of Va./ Oscar Mayer/ Univ. of Wisconsin	3,746	82	2.99	Design
Shelbyville, Tenn.	Poultry processing	Linear fresnel	Tyson Foods/ Lockheed	4,682	60	3.32	Design

*plus 44,000 ft² of reflectors

Table 1-5. CYCLE 4: INTERMEDIATE-TEMPERATURE COST-SHARED INDUSTRIAL PROCESS HEAT FIELD TESTS (100°-288° C, 212-550° F)

Location	Process	Contracting Team	Collectors	Array Size (m ²)	Fluid Conditions	Designed Annual Energy Delivery (GJ/m ²)	Status
Fort Worth, Tex.	Corrugated board production	Bates Container/BDM	Parabolic trough	3,226	Steam 227° C 1.03 MPa	2.60	Construction
San Leandro, Calif.	Pressurized hot water for washing	Caterpillar Tractor/SWRI	Parabolic trough	4,682	Water 113° C 0.2 MPa	3.05	Construction
Pepeekeo, Hawaii	Cane processing and electricity	Hilo Coast Processing Co./Team, Inc.	Parabolic trough	4,097	Steam 204° C 1.14 MPa	3.48	Design only
Haverhill, Ohio	Chemical plant-polystyrene	U.S.S. Chemicals/Columbia Gas/H. A. Williams and ASSOC.	Parabolic trough	4,682	Steam 227° C 1.03 MPa	1.62	Construction

Table 1-6. "REPOWERING" INDUSTRIAL RETROFIT FIELD TESTS (CENTRAL RECEIVERS)

Location	Process	Contracting Team	Receiver Type	Area of Heliostats (m ²)	Receiver Temp. (°C)	Design Annual Energy Delivery (GJ/m ²)	Status
Bakersfield, Calif.	Natural gas processing	Arco Oil & Gas Co./Northrup, Inc.	Oil cavity	16,830	293	4.83	Design
Bakersfield, Calif.	Enhanced oil recovery	Exxon/Martin Marietta/Foster Wheeler	Water/steam cavity	40,125	297	5.01	Design
San Mateo, N. Mex.	Uranium ore processing	Gulf R&D/McDonnell Douglas/Foster-Wheeler/Univ. of Houston	Water/steam external	21,600	204	5.29	Design
Mobile, Ariz.	Oil distillation	Provident Energy Corp. Foster-Wheeler/McDonnell Douglas	Water/steam external	60,210	271	1.29	Design
Sweetwater, Tex.	Gypsum board drying	U.S. Gypsum/Boeing/Inst. Gas Technology	Air cavity	20,635	724	2.19	Design
El Centro, Calif.	Ammonia production	Valley Nitrogen Producers/PFR Engr., Systems/McDonnell Douglas	Gas cavity	58,860	790	5.04	Design

Table 1-7. SOLAR ENHANCED OIL RECOVERY FIELD TESTS

Location	Contracting Team	Collectors	Approximate Array Size (m ²)	Delivery Temp. (°C)	Designed Annual Energy Delivery (GJ/m ²)	Status
Bakersfield, Calif.	Exxon/Martin Marietta/Foster-Wheeler	N-S parabolic trough	22,760	121	3.25	Design
Bakersfield, Calif.	General Atomic/Petro-Lewis Oil	E-W parabolic trough	31,590	260	2.34	Design

SECTION 2.0

APPLICATION

A number of factors should be weighed when considering a solar thermal application to IPH. A list of factors favoring the use of solar energy is given in Table 2-1. When assessing the use of solar energy, cost-effective conservation alternatives should first be considered. When solar energy is selected, it is vital that the energy supplied by the collector array be delivered to the place that utilizes it best.

2.1 SUITABILITY ASSESSMENT

- Solar energy is generally favored in areas of high insolation, high ambient temperatures, and low pollution. (Local pollution, such as that caused by a cooling tower, is particularly detrimental.)
- In order to prevent collector damage, areas susceptible to extreme weather conditions (hurricanes, floods, hail, and high winds) should be avoided if possible.
- If collectors are to be ground-mounted, important characteristics are: flat or southward slope (for north latitudes), shade-free, secure from future shading, and suitable soil.
- Important characteristics for roof mounting are: adequate support, easy access, suitable slope, and orientation.
- Availability of an on-site maintenance crew can be an important asset to a solar collector installation.

2.2 PROCESS LOCATION

- Thermal losses can be minimized by choosing a solar application process that requires a short pipe run to the collector field site.
- An interface location that allows for most of the pipe to be run indoors will minimize heat losses and weather degradation problems, although code requirements must be considered in the case of flammable fluids.
- The solar/process interface should be designed in such a fashion that utilization is maximized; e.g., the system should allow solar energy to be used even if a portion of the plant is shut down.

2.3 PROCESS TEMPERATURE AND SCHEDULE

- After cost-effective conservation measures have been exhausted, there is usually an advantage in supplying energy to the lowest temperature load possible to maximize collector efficiency and minimize thermal losses.
- Solar energy is best suited to processes that do not require a precise temperature control.
- Load schedules that are fairly constant throughout the year or that peak in the summer are preferred.

Table 2-1. FACTORS FAVORING THE APPLICATION OF SOLAR IPH SYSTEMS***Environmental Factors**

- High insolation levels—either total or direct, depending on the solar technology proposed.
- High ambient temperatures—to reduce thermal losses (particularly for non-concentrating collectors) and to allow the possible use of water as a heat transfer fluid.
- A pollution-free microclimate—so as not to dirty or corrode collector surfaces.
- A polluted macroclimate or area with strict air pollution regulations—where no additional air pollution emissions are allowed, and where such controls are a restraint on levels of production.

Process Factors

- Lower temperature processes—so that the least expensive type of collector, operating at a high efficiency, can be employed.
- Continuous, steady operations (24 h/day, 7 days/week) where exact temperature control is not critical.
- Liquid heating applications as opposed to air.
- Built-in process storage—which helps even out fluctuations in the thermal output of the collectors, and which can act as a reservoir to store heat (during the weekend, or long summer evenings) produced by the solar system.
- Easy retrofit of the solar system—so as to minimize costs.
- Inefficient present fuel usage, not easily rectified—so that energy delivered from the solar system replaces more than the equivalent Btu content of fossil fuel.

Economic Factors

- High and rapidly escalating fuel costs.
- Uncertainties regarding fuel supplies—such as interruptible natural gas contracts.
- Industry has, or has access to, sufficient capital to finance investments in a solar energy system.
- Industry applies long payback periods or will accept low rates of return on energy investments.
- High federal, state, or local tax incentives for solar investments.
- Industrial operation is energy intensive, and energy costs represent a large fraction of value added.
- Industry has exhausted economical energy conservation measures.
- Cheap land or a strong roof is available close to the delivery point of the required energy. Salt is available at little or no cost, if a salt pond is a solar option.
- Low labor cost area—since solar installations are labor intensive.
- New plant—allowing a solar system to be incorporated from the beginning with savings on the conventional heating system.

Company Factors

- The industrial plant wants to install a solar system and has an enthusiastic work force from top management down.
- The plant possesses a skilled maintenance and engineering work force—so as to run and maintain the solar system at maximum efficiency.
- Progressive management—which gives some recognition to the noneconomic but social values of solar energy, such as public relations, security of long-term supply, and reduced air pollution, leading perhaps to the application of less stringent payback criteria to investments in solar systems.

*Adapted from: Hooker, Douglas W.; May, E. Kenneth; West, Ronald E. 1980 (May). Industrial Process Heat Case Studies. SERI/TR-733-323. Golden, CO: Solar Energy Research Institute.

- On a daily basis, loads that are constant or peak during daylight hours are preferred.
- Loads that run seven days per week will minimize or eliminate storage requirements.

2.4 PROCESS TYPE

- In general, a solar energy system should not be considered until more cost-effective conservation alternatives have been exhausted. For example, it would be inadvisable to construct a solar energy system to supply boiler feedwater pre-heat if waste heat could be utilized more cheaply.
- A process that dictates a complex solar control system should be avoided since this would add to the cost and reduce reliability.
- It is preferable to select a process whose controls can be readily modified to maximize solar energy usage. (For example, some boilers may be readily modified to operate at lower firing rates.)
- Solar energy will be most economical for processes that use an expensive fuel (or one subject to curtailment) or burn fuel inefficiently.

SERIO 

SECTION 3.0

OVERALL SYSTEM DESIGN TRADEOFFS

Once the process load has been chosen and its temperature and schedule are known, the overall solar energy system must be designed. It must be decided, for example, whether a heat exchanger will be used and whether storage is worthwhile. For closed loop applications a heat transfer fluid must be chosen from the numerous types available. If steam is to be generated, the alternatives of a flash tank versus unfired boiler must be considered. (Although direct boiling in the collectors is a future possibility, this is still in the research phase.) In any case, an optimum collector area must be determined. The system design must occur concurrently with the choice of a collector, but for simplicity we have covered the latter separately in Section 4.0. In addition, the optimum system design can only be achieved in conjunction with a thorough study of the economics and accurate predictions of energy delivery (covered in Sections 9.0 and 8.0, respectively).

3.1 SIZING AND CONFIGURATION

- Where process hot water is needed on a once-through basis, the use of an open loop arrangement (process water flowing directly through the collectors) will minimize collector operating temperatures. A closed loop, however, has advantages of simple freeze protection and less corrosion.
- For steam applications, a tradeoff exists between use of an unfired boiler and a flash tank. A flash system (Fig. 3-1) eliminates some equipment cost and can potentially improve collector efficiency, but it requires freeze protection in most climates, increases the problem of corrosion, and consumes considerably more pumping power. A system employing an unfired boiler (Fig. 3-2) can, in some situations, have a greater collector efficiency than a flash system if a process preheater is used between the collector inlet fluid and make-up water, thereby lowering the collector inlet temperature.
- Ideally an optimum collector area is chosen based on a total system life-cycle cost analysis. If the solar system does not exhibit a net positive savings, then other factors must be considered. In general, too large a collector area will result in excess energy collection and poor utilization. Experience has shown that too small a collector area can result in neglect by the plant owner, since the impact on fuel cost would be small. Other limitations such as roof or ground area, budget, etc., also come into play.
- The optimum flow rate is a function of collector efficiency, pumping power, heat losses, and corrosion considerations. In weighing these characteristics it should be kept in mind that the efficiency of certain collectors can be sensitive to changes in flow rate.
- Since the varying nature of solar-supplied energy can affect the process, the total system (solar and process) should be considered in the design tradeoff. (For example, the solar energy supply could reduce process boiler efficiency by causing the boiler to cycle or run below rated capacity.)
- If the solar energy system is designed in such a fashion that it can be completely isolated from the process, any problems in the solar system will not result in process downtime.

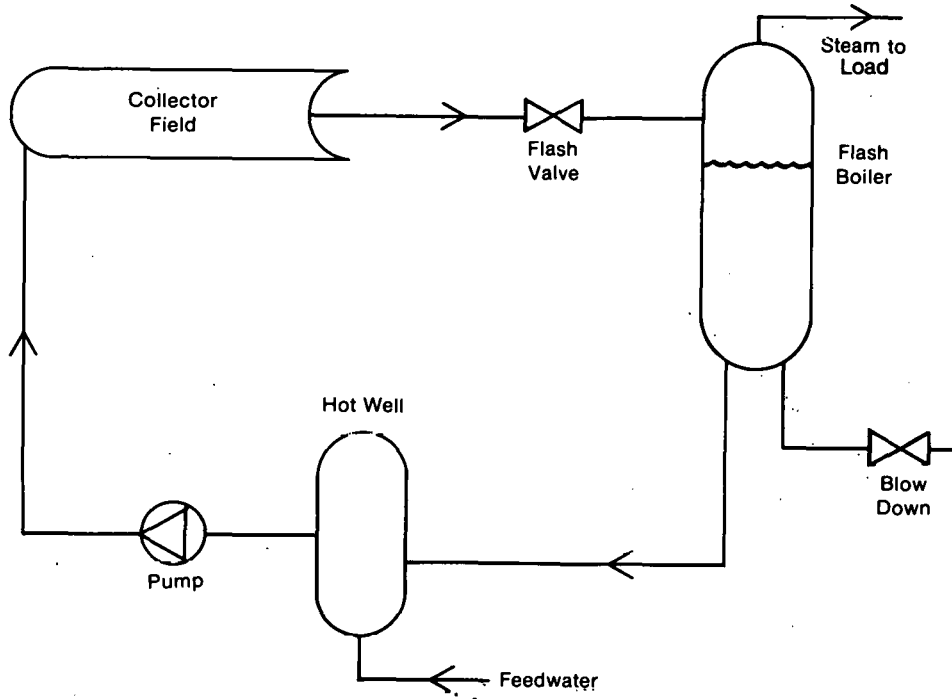

Figure 3-1. Steam Flash System

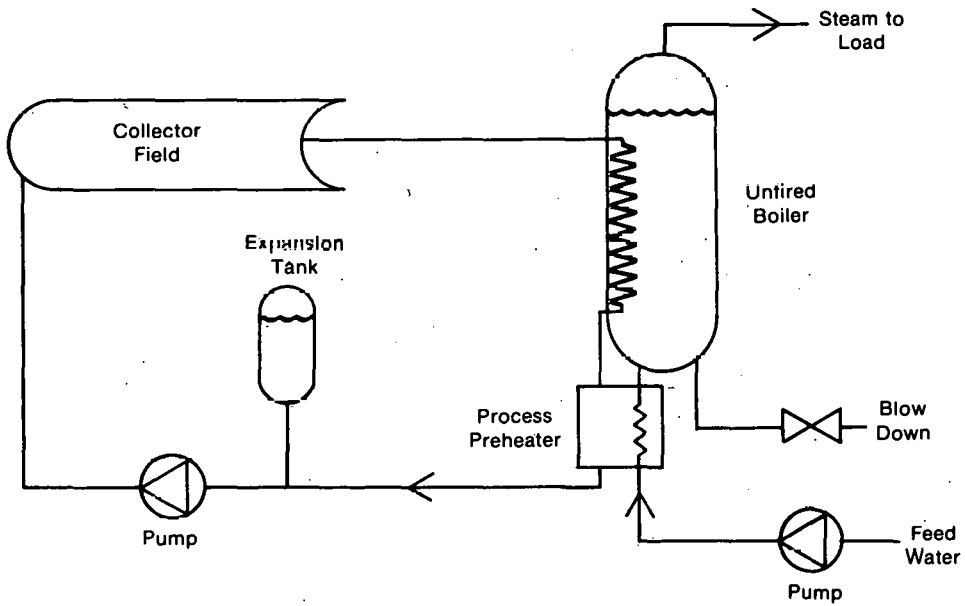

Figure 3-2. Unfired Boiler Steam System

3.2 STORAGE

- If solar energy supplies only a small fraction of the process load, storage would ordinarily not be warranted unless the collectors might otherwise not be utilized for significant periods of time (e.g., if the plant is shut down over weekends).
- Storage can be worthwhile if the collector array is of sufficient size to supply more energy than required by the load during times of peak insolation.
- When storage is to be used, it is often best to design for an unpressurized tank, since pressurized tanks are much higher in cost.

3.3 HEAT TRANSFER FLUIDS

- In choosing among heat transfer fluids, performance can be compared on the basis of pumping power and heat transfer capability. These are often expressed in a single term known as heat transfer efficiency factor, or HTEF, which is the ratio of heat transfer coefficient to pumping power [Fried 1973].
- Flammability is a particularly important characteristic where solar installations are concerned. High-temperature heat transfer fluids typically have low surface tensions and are therefore leak-prone. A large number of connections and the use of flexible hose in solar systems increase the probability of leaks, which can result in a fire. A rooftop location can greatly aggravate the consequences of this problem.
- In evaluating the pumping power required for a fluid, the higher viscosity at cold start-up must be considered in addition to normal operating characteristics. This is particularly crucial in the case of paraffinic oils.
- Other fluid characteristics such as vapor pressure, corrosiveness, and toxicity also play an important role in the selection process.
- Unacceptable environmental effects of a spill must be considered in the selection of a fluid and in the system design.
- The stability of the heat transfer fluid at the maximum anticipated temperature, including the stagnation temperature for nontrackers, should be considered.
- For fluids requiring maintenance, the cost of a maintenance plan and the handling of make-up fluid should be considered.



SECTION 4.0

COLLECTORS

The collector is the heart of any active solar energy system. It is vital to choose a collector that matches the process temperature and maximizes energy delivered per dollar invested. Many collector types are available, but the types that have thus far been employed in the industrial process heat field test program are:

- Flat-Plate Collectors—These are the most common type for applications below 70° C (160° F). Both liquid and air collectors are represented.
- Evacuated Tubes—These have been used for applications below 175° C (350° F).
- Linear Concentrators—Parabolic trough collectors have been used extensively in the IPH program for applications as high as 315° C (600° F). In one project a multiple-mirror concentrator was employed.

The collector array can be mounted either on the ground or on an available roof. In areas where land is very expensive, the latter approach might be less expensive if added roof support requirements are minimal. (For parabolic trough collectors, this has proved unlikely because of high point loads.) Nontracking collectors are ordinarily oriented as close to due south as possible and tilted at an angle determined by the annual load profile. Linear concentrators are normally mounted horizontally, with an orientation dependent on load profile and desired energy delivery. In designing a support structure, climatic effects such as snow, wind, etc., play an important role.

4.1 SELECTION

- Before selecting a concentrating collector, it is important to obtain the best possible estimates of direct radiation available at the site. Since concentrating collectors can essentially collect only direct and not diffuse radiation, the proportion of direct and diffuse radiation can be as important as the total radiation.
- It is important to consider the parasitic energy (pumps, fans, trackers, etc.) that will be required by a particular collector array. Air collectors in the field have consumed an especially large amount of parasitic energy.
- It is essential that nontracking collectors be capable of withstanding stagnation (i.e., no-flow) conditions without outgassing or otherwise deteriorating.
- In comparing the performance of candidate collectors, an annual efficiency should be used—not just that at solar noon. Since the performance of a collector array can vary significantly from that of an individual collector, some attempt should be made to estimate array performance (including header losses, for example). In addition, no collector in the field for a significant time will perform as well as a new collector on a test stand, and this should be accounted for. (An analogy to this would be the use of fouling factors in predicting actual heat exchanger performance versus the performance of a new clean heat exchanger.)
- To perform a fair comparison of different collector types, the entire system must be optimized for each. For example, in comparing flat plates with

parabolic troughs, the flat plate might be more attractive if greater measures are taken to reduce collector inlet temperatures (such as the addition of a pre-heater). In each case the total installed life-cycle energy cost, \$/(GJ/yr), should be determined.

- Ordinarily, the "best" collector is one that yields the lowest system life-cycle cost per unit of energy displaced. The cost should include installation, operation, and maintenance over the life of the system, and the energy should be determined as discussed above.
- The collector choice will, to a certain extent, also be dictated by the need for maintenance and the ability of plant personnel to supply that maintenance.
- It is recommended that, whenever possible, complete test data from an independent test laboratory be obtained. For nontracking collectors this should include instantaneous efficiency data, incident angle modifiers, and 30-day stagnation results.
- It is recommended that collectors be considered only if field experience data is available. When possible, it is highly advantageous to consult people who have had experience on a previous project with the collector model being considered.
- Collectors have proven to be highly susceptible to damage during shipment; therefore, it is important to inspect shipments for damage immediately upon delivery. Great care should also be taken in handling collectors during unloading and installation.

4.2 LOCATION

- The collector array should be located in an area where contaminants, such as cooling tower or boiler stack effluents, are least likely to be a problem.
- In general, the collector array location should be chosen to avoid shade from trees, buildings, or anticipated future structures.
- Legislation on solar access is rapidly evolving, and it is advisable to determine the latest laws that apply to the chosen site.
- It is advisable to consider the possibility for future expansion when choosing a collector site.
- Since vandals have occasionally been a problem at existing solar sites, some thought should be given to providing protection; e.g., in the form of a perimeter fence. Of course, this must be carefully weighed against the cost.
- Normally, ground-mounted structures are less expensive and more reliable than roof-mounted ones. Roof mounting can offer advantages of shorter pipe runs and a savings in land cost and deserves consideration, particularly in new structures if a nonflammable heat transfer fluid is used. If a roof-mounted array of tracking linear concentrators is being considered, the possibility of outgassing of roofing materials (such as tar) onto the collectors when they are in a face-down stowed configuration should be addressed.

4.3 MOUNTING, ORIENTATION, AND TILT

- Unless the daily load or climatic conditions are skewed to favor morning or afternoon operation, maximum energy delivery can be obtained by orienting nontracking collectors to face as close as possible to geographic (not magnetic) south. In general, the potential energy collection is decreased less than 5% for a variance from due south of as much as 20°; however, the potential energy collection decreases rapidly for larger deviations.
- A tilt angle for nontracking collectors approximately equal to the latitude is generally considered best for uniform annual load profiles. Larger tilt angles will favor winter collection; smaller angles favor summer collection.
- Tracking linear concentrators are usually mounted horizontally to save support costs. Orienting the axis of the collectors north-south maximizes energy output but results in substantial summer peaking. An east-west orientation will collect less energy on an annual basis but will provide a more uniform annual energy output.
- It is advantageous to conduct an annual performance simulation, including hour-by-hour calculations, to determine the optimum collector tilt and orientation for the particular process load profile.
- Sandia Laboratories has conducted wind tunnel tests to determine structural requirements for parabolic trough collectors, and this data is available for the designer [Randall 1979].
- When arranging the layout of collector rows, spacing must be sufficient to prevent excessive self-shading. This must be weighed against the reductions in costs of piping and land, thermal losses (both steady state and overnight), and parasitic power requirements that result from a close spacing. Also, spacing must be sufficient to allow for adequate access by maintenance personnel and equipment.
- Since roof leaks have been a common problem with roof-mounted solar arrays, roof penetrations should be kept to a minimum.

4.4 MAINTENANCE

- Whenever possible, maintenance should not be performed during hours of collector operation.
- A regular collector washing program can be essential, especially for concentrating collectors that require high specular reflectivity. Aluminum reflectors have been shown to be particularly susceptible to degradation in specular reflectivity and in some environments may require frequent washing.
- A routine inspection plan that includes performance monitoring can uncover problems before they become severe. Some items that should be included on an inspection checklist are reflective surfaces, transparent cover materials, absorber surfaces, flexible connections, fluid leaks, and heat transfer fluid condition.
- Control of vegetation in the collector field may be an essential maintenance consideration.

SERIO 

SECTION 5.0

PIPING AND MECHANICAL SUBSYSTEMS

The performance, reliability, and cost of a solar IPH system are strongly affected by the piping layout, pipe diameter, and selection of components such as pumps, heat exchangers, valves, fittings, etc. When compared with conventional energy systems or solar heating and cooling applications, solar IPH systems show a much greater sensitivity to the piping system because of the large pipe runs which are often needed. It is generally advisable to use only off-the-shelf components for which parts and service are readily available.

5.1 PIPING AND INSULATION

- In order to provide more uniform flow, piping is often connected in reverse-return rather than direct-return (Fig. 5-1). In large IPH applications, however, the added piping fluid inventory and its associated overnight losses can significantly affect system performance. Reverse return piping is also higher in cost. Thus, although reverse-return piping can be beneficial, it should be carefully weighed against a direct-return system employing balancing valves.

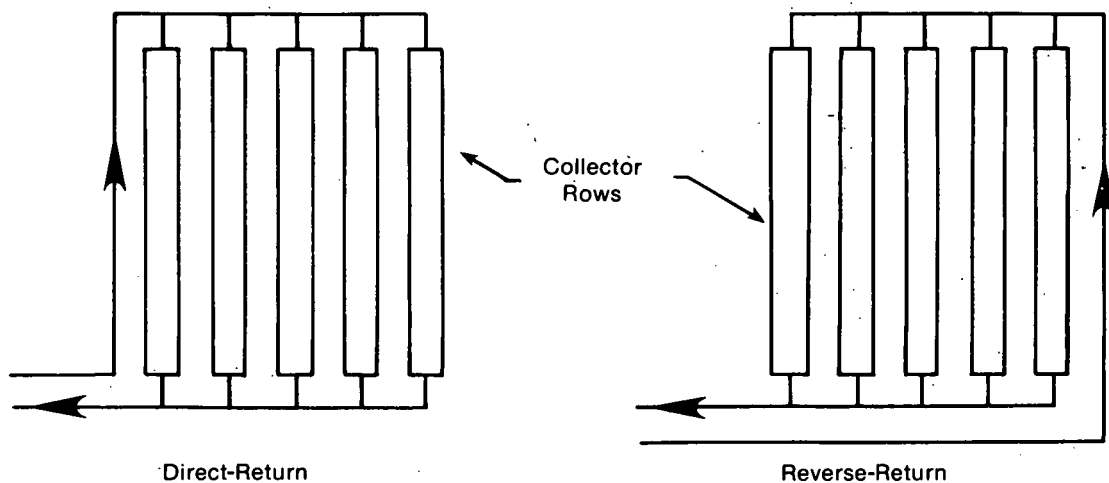

Figure 5-1. Direct-Return and Reverse-Return Piping Systems

Note that hot leg is shorter in each case.

- When the supply and return pipe legs to the collector array are of unequal length, it is usually advantageous to keep the return (hot) leg shorter than the supply (cold) leg in order to reduce thermal losses.

- A pipe size optimization should include all of the following system characteristics: installed cost of piping, insulation, and fittings; life-cycle pumping power costs; steady-state (operational) heat losses; and overnight heat losses. The last parameter in particular has frequently not been given the attention it deserves.
- In selecting pipe sizes, only those that are readily available off-the-shelf should be considered.
- The heat transfer fluid used can affect the type of insulation chosen. If the heat transfer fluid is flammable it will also probably be leak-prone. Use of a non-wicking insulation will reduce the chances of spontaneous combustion. In order to minimize costs, this insulation will sometimes be used only in those places susceptible to leakage, such as valves, flanges, etc.
- Care should be taken to protect insulation from burning by focused sunlight in tracking collectors.
- Since open cell insulation can degrade when wet, adequate waterproofing should be provided. Because of its greater resistance to moisture, closed cell insulation may be worth the added cost.
- When flammable leak-prone fluids are used, mounting valve stems in a horizontal position will minimize the possibility of a fluid leak saturating the insulation. (When saturation occurs, the large surface area available for oxidation can result in temperatures sufficiently high for auto-ignition.)
- Considerable heat losses can occur through pipe supports. Therefore, it is worthwhile to thermally isolate pipe supports from the pipes, for example, with noncompressible insulation. Care should be taken, however, not to compromise the integrity of the supports.
- In systems using leak-prone fluids, welded fittings are more leak-resistant than threaded or flanged fittings.
- It is important to supply adequate pipe slope and a sufficient number of drain valves to ensure collector drainage.
- If considering the use of plastic pipe, be aware that it can become brittle at low temperatures, can fail at high temperatures, and may be susceptible to degradation by ultraviolet light.
- Locating thermowells and pressure taps at critical points during piping design can save on costs later.
- The effects of pressure surges during start-up (e.g., on bellows) should be considered during design.
- In providing for pipe expansion a decision must be made between bellows and expansion loops (Fig. 5-2). The latter can result in greater thermal losses. However, they are more reliable and less prone to leakage, and when flammable fluids are used, this is an important factor.
- Flex hoses should be installed in such a fashion that they experience a minimum amount of torque and tension. They should also be well protected from the weather.

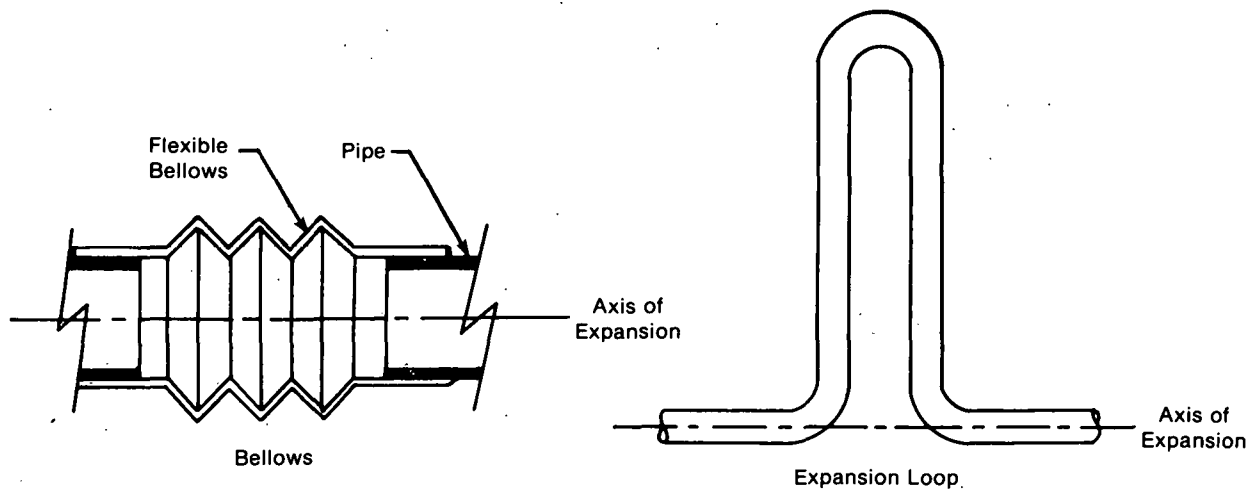

Figure 5-2. Bellows and Expansion Loops for Thermal Expansion

5.2 PUMPS AND FANS

- When the viscosity of the heat transfer fluid used differs greatly between cold start-up and normal operating temperatures, it is often advisable to use a separate pump for start-ups (e.g., a positive displacement pump).
- It is important to be sure that the collector pump (or fan) is sufficient in capacity to supply the flow rate required by the collector. Low estimates of system head losses have created problems in the past.
- Pumps, including all seals and bearings, should be rated for duty with the heat transfer fluid to be used and maximum temperatures expected. It is good practice to have spare seals and bearings on hand.
- To minimize parasitic power consumption, it is important to choose the pump or fan that is most efficient for the application.
- In order to prevent cavitation, ensure that the pump will have sufficient net positive suction head under all operating conditions, particularly at the highest temperatures expected.
- A pump should not be throttled below the manufacturer's minimum recommended flow rate.
- To improve reliability, the use of parallel pumps can be considered. Also, the staging of pumps can reduce parasitic power consumption by allowing lower flow rates during low-insolation conditions.
- Pump seal cooling can result in significant thermal loss from the collector loop. Certain seal configurations require substantially less cooling than others during high-temperature operation.

5.3 VALVES AND DAMPERS

- Three-way valves tend to seal poorly and, when possible, their use should be avoided.
- A sufficient number of isolation valves should be provided to permit servicing of collectors, pumps, etc. Check valves will not supply positive shutoff.
- The use of check valves, shutoff dampers, or a vertical U-section of pipe in a closed collector loop will prevent thermosiphoning which can result in heat loss or freeze-up.
- In a pressurized system there should be a sufficient number of pressure relief valves that no portion of the collector array or piping that receives heat input can be isolated without pressure relief.
- Pressure relief valves should be of sufficient capacity to handle the worst pressure transient.
- Discharge from pressure relief valves should be piped to a safe area to avoid injury to people near the valves and to avoid damage that heat transfer fluids can cause to roofing materials and the environment.
- While truly "leak-proof" dampers for air systems are somewhat expensive, every effort should be made to choose dampers that supply positive shutoff and that will not leak air to the outside of a ducting system.

5.4 HEAT EXCHANGERS

- Selection of a heat exchanger size and design should occur in conjunction with the selection of system flow rate to minimize cost and maximize collector efficiency. (For example, supply the lowest possible temperature to the collector array inlet.)
- Whenever potable water is being heated and the collector loop is closed, a double-walled heat exchanger (or two separate heat exchangers) is strongly recommended. Even if the fluid in the collector loop is considered nontoxic, it can deteriorate with time (especially at high temperature) or could be inadvertently replaced with a toxic substitute during maintenance.

5.5 STORAGE

- It is important for purposes of maintenance and servicing to ensure that the storage system is readily drainable.
- Thermosiphon heat transfer occurring between a storage tank and external components can cause significant thermal losses and can be avoided by suitable design of the piping system.
- Heat leaks due to pipe penetrations and support structures should be considered and minimized.
- The possibility of corrosion in steel storage tanks may be minimized through the use of a lining or a getter.

- Because of the variable nature of the solar supply, consider allowing the volume of liquid in a storage tank to be variable during operation in order to maximize system efficiency.
- In moderate climates, recirculation between storage and the collector array may be used for freeze protection and should be considered along with other possibilities.
- To minimize silt accumulation and corrosion, avoid the use of raw water in storage (e.g., well water).
- In rock bed storage systems, it is important to design for sufficient plenum size to ensure even flow. A good rule-of-thumb is that the plenum area should be at least 12% of the bed cross-sectional area.
- Be aware of the possibility of uneven settling of rocks in rock bed storage units that can cause irregularities in flow. In general, the size of rocks should be kept within the range of 3/4 to 1-1/2 times the nominal rock diameter.

5.6 MAINTENANCE

- Heat transfer fluids subject to degradation should be monitored regularly. In glycol-water systems, for example, the pH should be checked once per month and also following any stagnation condition.
- Thermal cycling due to the cyclical nature of the solar supply may cause sticking of control valves and loosening of unions and other fittings, requiring periodic retightening to specified torques.
- The high cost of some heat transfer fluids may make draining and storage of the fluid inventory during maintenance more cost-effective than replacement.
- Thermal cycling in the presence of heat transfer oils has resulted in degradation of asbestos gaskets. Graphite products have been found to be effective in such applications [McCulloch 1980].
- The control room and equipment rooms should be designed to supply ample room for maintenance and service.

SERI 

SECTION 6.0

INSTRUMENTATION AND CONTROLS

A carefully designed control system is needed to maximize the energy delivery, provide freeze and stagnation protection, and handle emergency conditions that could threaten safety or component life. Experience has shown that the control system should be as simple as possible to ensure that it will provide for trouble-free operation.

6.1 NORMAL OPERATING MODES

- The control system must allow for varying cloud cover, which can cause time variations in irradiation as well as partial shading of the collector array.
- Sufficient deadbands in the control system are necessary to prevent pump cycling.
- When possible, control points (such as irradiance threshold for tracking) should be adjustable to permit fine tuning in the field.

6.2 START-UP/SHUTDOWN

- To test all system operating modes and responses to normal and emergency conditions, a detailed start-up checkout procedure should be devised.
- On shutdown, overnight thermal losses may be reduced by extracting as much energy as practical from the collector field.

6.3 FREEZING/STAGNATION PROTECTION

- The use of a drain-back system is one option for freeze protection and can also reduce overnight losses. However, note that use of this technique may increase problems of scaling and corrosion in collector piping and result in problems of air-binding at start-up.
- For drain-down or drain-back systems, ensure that pipe slopes are adequate for proper drainage. Allowance for roof load deflections and settling should be made.
- In choosing a set point for drain-down, take into account the fact that night radiation losses in dry climates can cause fluids to freeze, although the ambient temperature may be well above the fluid freezing temperature.
- To protect the system against severe weather or electrical outages, freeze protection should function even in the event of a power failure.
- Makeup water in an antifreeze system must be controlled to avoid inadvertent dilution of the fluid.
- Hot water circulation (e.g., from a storage tank or flash tank) for freeze protection may involve significant heat losses over a year of operation. In general, this type of freeze protection should be considered only for moderate climates.

- Freeze protection sensors must be located at the coldest point in a system. Several sensors in different locations may be necessary to ensure complete protection against freezing.
- The use of collector covers, a heat rejector, or allowing for boil-off of fluid in a storage tank will reduce the possibility of damage to nontracking collectors if they will experience significant time periods with no load (e.g., plant vacations). This is especially important for evacuated tube collectors due to their high stagnation temperatures.
- Control logic can protect collectors from thermal shock damage by preventing stagnating collectors from being filled with cold fluid when they are above a critical temperature. For example, if evacuated tube collectors stagnate during the day, the collector circulating pump should not be restarted until they have cooled to a safe temperature.

6.4 EMERGENCY CONDITIONS

- Automatic stow of tracking collectors should be initiated independently by high temperature in any row, low flow in any row, or high wind.
- In the event of power failure, an automatic back-up system on tracking collectors should cause the collectors to automatically stow. In general, a tracking collector should not be allowed to sit in a stationary sun-facing position with no flow. This is particularly critical for trackers oriented east-west, since they can remain in focus for a considerable length of time without tracking.
- Emergency and abnormal conditions should be signalled to the operator via visual and audible alarms.
- Black chrome selective surfaces on absorbers of tracking collectors can be damaged if the high-temperature stow control set point is too high.
- A total system "kill" switch, protected from inadvertent use, should be provided for fire protection. The switch should stop flow of fluids, stow collectors, and be accessible to firemen.
- Checking of automatic emergency operations is made easier and safer if provision is made for electrical simulation of the control inputs.

6.5 OPERATOR TRAINING/DISPLAYS

- Operators should be trained in all of the normal and emergency operating modes of the system. They must be capable of reacting to alarms and must know how to perform a checkout procedure.
- The operator should keep a daily log of unusual occurrences, corrective actions, and routine maintenance activities.
- To keep the operators aware of system performance, a display panel should show the attitude of tracking collectors and temperature and flow characteristics throughout the system. The display panel should be located as near as practical to the operator's normal work station and, wherever possible, the collector field should be visible from the display panel location.

- If a data acquisition system is used, the operator should be familiar enough with it to be aware of problems when they occur and should know how to start it up, replace tapes and paper, etc.
- Training and drills should be provided to the operators to assure that they can handle emergency conditions such as fires.

6.6 EQUIPMENT

- Long lead wires from sensors in solar systems may require the use of signal conditioners located in the field and proper shielding of leads.
- Sensors must be chosen so that they can read the desired quantities in all operating modes. For example, freezing sensors must be capable of reading the coldest temperature in the collector loop as well as withstanding stagnation temperatures without damage.
- Whenever possible, control equipment should be of the same order of sophistication as that used in the conventional portion of the plant. In this way the plant maintenance personnel can attend to the solar controls. For example, when adequate, a bimetallic switch might be used in place of a solid state controller.
- Signal wiring must be protected from concentrated sunlight in tracking collector systems.
- Considering the effects of thermal cycling, sensors should be calibrated frequently according to the manufacturer's recommendations.
- Use of locally serviceable control equipment will lessen the impact of equipment failures and reduce the duration of downtimes.
- For good irradiance measurements, pyranometers should be kept clean and shadow bands should be adjusted often.
- The use of dependable visual gauges near control sensors will facilitate troubleshooting.

SERIO 

SECTION 7.0

INSTALLATION AND START-UP

The installation and start-up of a solar system requires special attention if the system is to perform well. Although many components of a solar system are similar to conventional systems (e.g., high-temperature fluid piping and storage tanks), there are many aspects that require special consideration in construction and start-up. Also, solar energy systems are new and unfamiliar to contractors, and this unfamiliarity can lead to unexpected difficulties.

7.1 CONSTRUCTION

- Due to unfamiliarity with the construction of solar systems, contractors' construction cost estimates may be high in order to offset unrecognized issues.
- Proper scheduling during construction can help protect fragile collectors from dust and breakage.
- To avoid damage, most nontracking collectors should be protected from stagnation.
- All delivered equipment, especially collectors, should be inspected for damage upon receipt, in order that damage claims can be quickly filed.
- Design limits vary among different brands of line-focus collectors, but an absolutely level site is not required for most models. A slight amount of slope will, in fact, aid in drainage.
- In northern latitudes, mounting the collector array on a slight southern slope may be beneficial by reducing the collector support structure for nontracking collectors or allowing closer spacing of linear focus collectors mounted east-west. Increased performance from north-south mounted line focus collectors is possible if they are designed to withstand the increased end loads on the bearings due to the tilt.
- For line-focus collectors, the load-carrying requirements of struts and pylons vary with their position in the string and in the array. Interior strings are better shielded from wind loads and so need less strength.
- Augering and filling with concrete is often more cost-effective than using massive floating pier-type foundations for collectors.
- Flexible bellows may require heat sink protection for welding and soldering.
- Roofs should be protected from damage during construction of roof-mounted collector arrays or pipe runs.

7.2 CHECKOUT/COMMISSIONING

- During checkout, a demonstration should be made of each operating mode, including emergency conditions.
- Ensure that all fluid lines are flushed and all filters cleaned before allowing flow through the collectors, since collector flow passages are small and may become plugged.

SECTION 8.0

ENERGY DELIVERY PREDICTION

When one compares the actual versus predicted annual energy deliveries for presently operating IPH field tests, the predicted values substantially exceed the actual values (in some cases by a factor as high as five) [Kutscher and Davenport 1980]. For industrial owners to have confidence in a solar system design, it is vital that more accurate predictions be made. Some of the reasons for overprediction in the past are too high an estimate of solar irradiation (particularly direct irradiation), underestimating thermal losses both during operation and at night, failure to account for collector degradation, underestimation of parasitic energy consumption, lack of provision for system and plant downtime, and an incomplete understanding of how the load would interface with the solar energy delivery system.

8.1 IRRADIATION DATA

- To reduce uncertainty, actual measured data such as SOLMET [SOLMET Vol. 1, SOLMET Vol. 2] or reduced data such as TMY [Hall et al. 1978] should be used when available. When various sources disagree, it is best to make conservative estimates.
- Site measurements should be compared to the nearest SOLMET or weather station to account for effects of microclimate variations and any effluents near the site.
- Data on direct irradiation for tracking collectors are more reliable when from direct pyrheliometer or combination total and shadowband pyranometer measurements and not calculated from simple measurements of total irradiation.
- Different types of collectors will respond differently to direct and diffuse irradiation. Generally, flat-plate collectors are less sensitive to the amount of direct radiation than evacuated tubes, which are in turn less sensitive than linear concentrators. This sensitivity should be accounted for in the energy delivery calculations.

8.2 COLLECTOR EFFICIENCY

- To properly calculate energy delivery, estimates should be based on day-long collector efficiency, not just that at solar noon. Incidence angle effects can be important for tracking collectors as well as nontrackers. Shadowing and end losses of the collector array should also be considered.
- Dust accumulation and degradation of collectors in the field are important factors in estimating long-term performance of a solar energy system.
- For systems employing variable flow rate control of the collector loop, efficiency variation with flow rate should be included in performance modeling.

8.3 THERMAL LOSSES

- All steady-state losses should be taken into account, not only through pipe walls but also through valves, pipe supports, cooled pump seals, etc.
- The overnight loss of heat from the collector loop fluid inventory and from insulation and metal mass in the system is often significant and should be accounted for.
- If night circulation is used for freeze protection, the resultant thermal losses should be calculated.
- Be aware of the possibility that the insulation may get wet and substantially increase thermal losses.
- In estimating the performance of air systems, account for the effects of air leakage.
- All heat loss mechanisms inherent in the system design should be included, such as blowdown from an unfired boiler.
- The R-value of insulation varies with temperature, and values based on expected operating temperatures should be used. Insulation installation practices may result in lower R-value than the theoretical value (for example, due to compression).

8.4 PARASITIC ENERGY

- The parasitic energy consumed by a solar system should include all pumping and fan power (both during normal operation and for freeze protection) and energy used by the control and tracking systems.
- To place the proper significance on parasitic electrical energy use, the amount of fuel energy required at the central power plant to produce it should be considered. In general, when one accounts for efficiency of an on-site boiler as well, 1 unit of electrical energy is equivalent to about 2.7 units of fossil fuel energy.
- Most of the electrical energy supplied to pumps is transferred to the fluid in the system and should be included in performance calculations.

8.5 OVERALL SYSTEM PERFORMANCE

- Allow for a realistic amount of solar system and process downtime based on the experience of previous IPH projects [Kutscher and Davenport 1980].
- Account for the actual daily plant operation schedule, allowing for a realistic amount of process downtime unrelated to solar system downtime.
- Survey what computer simulation programs are available at the start of design. Hour-by-hour computer analyses are valuable, but be aware of all assumptions made in the algorithms. Some ignore overnight losses, for example.
- Short transients in irradiance due to intermittent cloud cover may not allow collectors to operate even though the integrated total irradiation would be sufficient if it were steady. This effect should be accounted for in performance modeling.

SECTION 9.0

ECONOMICS

The final goal of any solar system design is to provide the largest amount of energy at the lowest possible cost. Therefore, it is important to estimate in detail the system capital and operation and maintenance costs versus the cost of fossil fuel saved over the system life. A useful method of economic analysis for IPH projects has been developed by W. C. Dickinson and K. Brown and is currently being used on all DOE projects [Dickinson and Brown]. The Dickinson-Brown methodology uses life-cycle costing, which is preferred by economists since payback period analyses do not account for the savings during the time after the payback period.

In performing the economic analysis of a solar IPH system, it is important to take into account the latest local, state, and federal solar tax incentives, all of which are rapidly evolving. Cost breakdowns of 10 DOE-sponsored solar IPH field tests will soon be available in the final report of a study conducted for the Solar Energy Research Institute by Mueller Associates, Inc. [Mueller].

SERIO 

SECTION 10.0

DATA ACQUISITION

Data acquisition systems proved to be unreliable in the first operating IPH projects funded by DOE [Bush and Kutscher 1980]. As a result, a great deal of valuable data was lost. To correct this situation for DOE projects, data acquisition system guidelines were published that specified in more detail the type of equipment and methods deemed necessary to obtain useful data [Kutscher 1979]. Several key points of a general nature are given below.

- The data acquisition system (DAS) should be located in a temperature- and humidity-controlled environment sheltered from dust, water and steam leaks, and vibration.
- Monitoring all energy flows from incoming solar radiation to final energy delivery will facilitate the detection of any problems.
- For completeness of data, the DAS should be capable of taking data whether or not the solar system is operating.
- To reduce the problems associated with power outages, the DAS should be equipped with battery back-up to keep track of time and maintain memory.
- It is recommended that all final performance parameters (with the exception of heat loss terms involving small ΔT 's) be determined to within 6% accuracy based on an rms uncertainty analysis as described in NBSIR 76-1137 [Streed et al. 1978].
- Measurement of small differences, such as the temperature drop along a pipe, are difficult to make and require higher individual accuracy than other measurements for the same tolerance. For small temperature changes, the use of matched probes is recommended.
- A good guide to sensor installation for solar applications is IBM's "Instrumentation Installation Guidelines" [IBM Corporation]. Not stressed in that document, however, is the importance of utilizing sufficient immersion depth for temperature probes.

SERIO 

SECTION 11.0

SAFETY

The major concerns when dealing with the safety of a solar energy system are fire hazards, eye hazards due to reflected and concentrated light, steam and hot fluid leaks, exposed hot surfaces, and fluid toxicity. As with any energy system, common sense must be used in protecting against hazards.

11.1 HARDWARE

- Fences and warning signs around the collector array should be considered to prevent the possibility of bodily injury.
- For fire protection, a total system kill switch should be provided to stop collector fluid flow and defocus and stop tracking collectors.
- Safe disposal or storage of fluid from pressure relief valves and rupture disks is essential for personnel safety and avoidance of damage.
- Lock-out switches and valves to eliminate unauthorized use should be considered at crucial positions.
- Berms should be considered around storage tanks to contain any large fluid leaks, especially in the case of flammable or toxic fluids.
- Heat transfer fluids should be kept in properly labeled containers.

For systems susceptible to fire the following considerations apply:

- Appropriate fire fighting equipment should be available at the sites of possible fires.
- Inspection by fire prevention experts is recommended before start-up.
- The local fire department should be made aware of the nature of fire hazards associated with the solar system (e.g., the fluids used), and easy access should be provided to the collector array for fire fighting equipment.
- Plant personnel should be trained in fire protection.

11.2 PROCEDURES

- As with any other high-temperature system, safety devices should be checked regularly and should not be bypassed for any reason.
- Safety training and drills should be employed to alert operators to possible hazards.
- All federal, state, and local safety codes should be followed.
- Emergency procedures should be developed for all contingencies.

SERIO 

SECTION 12.0

ENVIRONMENTAL ISSUES

Although solar energy systems are normally more environmentally benign than conventional energy sources, there are certain environmental effects that must be addressed. As with any large project, an environmental assessment must be made, and local environmental regulations must be complied with. Some of the environmental considerations of solar systems are listed below.

- Glare from the collector array can be an annoyance and a safety hazard. Care should be taken in the design and placement of collector arrays to minimize this problem.
- Spillage, leaks, and overflow of heat transfer fluids are potential sources of water pollution.
- The environmental effects of herbicides used to control weeds in the collector array should be assessed.
- Venting and evaporation of heat transfer fluids may result in local air pollution.
- Backflow preventors should be used to keep the solar system from contaminating water supplies.



SECTION 13.0

DOCUMENTATION

Any good system design, solar or otherwise, must have detailed accompanying documentation. This documentation will minimize the chance of construction and operating errors and provide for system troubleshooting, preventive maintenance, and future modifications.

13.1 DRAWINGS

- Process flow diagrams are important for understanding how a system operates. These show system temperatures, pressures, and flow rates for the various operating modes of the system.
- For system operation, a piping and instrumentation diagram (P&ID) is extremely important. This gives the piping and mechanical system configuration, including pipe sizes and storage capacities, and shows the locations of all data acquisition and control sensors.
- A set of as-built engineering drawings and specifications for structural, mechanical, and electrical systems is required for use in making future modifications and for review purposes. These should be consistent with drawings used by the construction trades (e.g., Construction Specification Institute (CSI)).

13.2 DOCUMENTS

- A control logic table in the form of an Instrument Society of America (ISA) Standard Binary Logic Diagram [Standards] is useful for illustrating operating modes. This table shows the positions of all valves for various control sensor readings.
- Precommissioning and commissioning checklists should be developed to assist in starting the system for the first time.
- An operation and maintenance manual should be prepared to provide a reference for the operators. Although such a manual can be revised after system start-up, it should be written before the end of construction so that it is available at start-up. It should be written in a manner that makes it useful to plant personnel, not design engineers.
- An energy flow diagram beginning with incident solar energy and showing all of the various losses is very useful in conveying system performance.
- An on-site maintenance log will provide information on system reliability.

SERIO 

SECTION 14.0

REFERENCES

Bush, G.; Kutscher, C. F. 1980. Data Acquisition for Solar Industrial Process Heat Field Tests. Proceedings: AS/ISES 1980 Annual Meeting; Phoenix, AZ; 2-6 June 1980.

Dickinson, W. C.; Brown, K. Economic Analysis of Solar Industrial Process Heat Systems: A Methodology to Determine Annual Required Revenue and Internal Rate of Return. UCRL-52814. Livermore, CA: Lawrence Livermore National Laboratory.

Fried, J. R. 1973 (28 May). "Heat Transfer Agents for High Temperature Systems." Chemical Engineering.

Hall, I. J.; Prairie, R. R.; Anderson, H. E.; Boes, E. C. 1978 (Aug.). Generation of Typical Meteorological Years for 26 SOLMET Stations. SAND 78-1601. Albuquerque, NM: Sandia National Laboratories.

IBM Corporation. 1977 (Nov.). "Instrumentation Installation Guidelines." SOLAR/001-77/15. IBM Corporation. p. 101. Available from National Technical Information Service, 5285 Port Royal Road, Springfield, VA 22161.

Kutscher, C. F. 1979 (30 Mar.). "Data Acquisition and Analysis Guidelines for Industrial Process Heat Demonstration Projects." SERI memo to Industrial Process Heat (IPH) Steam Contractors.

Kutscher, C. F.; Davenport, R. L. 1980 (June). Preliminary Operational Results of the Low-Temperature Solar Industrial Process Heat Field Tests. SERI/TR-632-385. Golden, CO: Solar Energy Research Institute.

McCulloch, W. H. 1980. Test Experience at the DOE/Sandia Midtemperature Solar Systems Test Facility. Report generated under Contract DE-ACO4-76DP00789. Albuquerque, NM: Sandia National Laboratories.

Mueller Associates, Inc. Forthcoming. The Analysis of Construction Costs of Ten Solar Industrial Process Heat Systems. Baltimore, MD: Mueller Associates, Inc.

Otts, John V. 1980 (Nov.). Operational Experiences and Insights Concerning Solar Thermal Field Experiments. SAND 81-0220. Albuquerque, NM: Sandia National Laboratories.

Randall, D. E. et al. 1979. Steady State Wind Loading on Parabolic Trough Collectors. ASME paper 80-C2/Sol-20, also SAND 79-2134. Available from: National Technical Information Service, 5285 Port Royal Road, Springfield, VA 22161.

SOLMET Vol. 1: User's Manual. 1977 (Dec.). TD-9724. Hourly Radiation-Surface Meteorological Observations. Asheville, NC: National Oceanic and Atmospheric Administration (NOAA). (Available from National Climatic Center; Asheville, NC 28801.)

SOLMET Vol. 2: Final Report. 1979 (Feb.). TD-9724. Hourly Radiation-Surface Meteorological Observations. Asheville, NC: National Oceanic and Atmospheric Administration. (Available from National Climatic Center; Asheville, NC 28801.)

Standards and Practices for Instrumentation. 1980. Instrument Society of America. Sixth edition.

Streed, E. et al. 1978 (Aug.). Thermal Data Requirements and Performance Evaluation Procedures for the National Solar Heating and Cooling Demonstration Program. NBSIR-76-1137. Washington, DC: Institute for Applied Technology, National Bureau of Standards. p. 78.

U.S. Department of Energy. 1978. Proceedings: Vol. 1. Solar Industrial Process Heat Conference. October 18-20, 1978. SERI/TP-49-065. Idaho National Engineering Laboratory. Golden, CO: Solar Energy Research Institute.

. Solar Industrial Process Heat Conference Proceedings. October 31-November 2, 1979. SERI/TP-333-429. Golden, CO: Solar Energy Research Institute.

APPENDIX A
SOURCES OF INFORMATION



Technical Reports Produced from U.S. Government-Sponsored Research:

National Technical Information Service (NTIS)
U.S. Department of Commerce
5285 Port Royal Road
Springfield, VA 22161
(703) 557-4600 (Write for free NTIS Energy Catalog-NTIS/PR-78)

SOLMET:

U.S. Department of Commerce
National Oceanic and Atmospheric Administration (NOAA)
Environmental Data Service
National Climatic Center
Asheville, NC 28801
(704) 258-2850 Ext. 683

TMY:

I. J. Hall, R. R. Prairie, H. E. Anderson, and E. C. Boes
Generation of Typical Meteorological Years for 26 SOLMET Stations.
SAND 78-1601, Sandia Laboratories, Albuquerque, NM, August 1978.

TRNSYS, F-Chart:

University of Wisconsin Solar Energy Laboratory
Engineering Research Bldg.
1500 Johnson Drive
Madison, WI 53706
(608) 263-1586

U.S. Department of Energy (DOE) Publications:

Technical Information Center (TIC)
U.S. Department of Energy
P. O. Box 62
Oak Ridge, TN 37830

Solar Product Information:Solar Products Specification Guide

Solar Age (magazine)

Published in 1979 by:

Solarvision, Inc.
Church Hill
Harrisville, NH 03450

Solar Engineering Master Catalog and Solar Industry Index. SEM 1980.
Solar Energy Industries Association, 1978.

General Information:

Solar Energy Information Locator
SERI/SP-751-210
Solar Energy Research Institute
1617 Cole Blvd.
Golden, CO 80401
(303) 231-1415

Solar Energy Information Data Bank (SEIDB)
Solar Energy Research Institute
1617 Cole Blvd.
Golden, CO 80401
(303) 231-1415

Superintendent of Documents
U.S. Government Printing Office
Washington, DC 20402
(Write for free Solar Energy Bibliography #9)

APPENDIX B
GLOSSARY

SERIO 

Closed Loop—A system configuration in which the collector loop contains a fluid separate (and usually different) from the fluid used in the industrial process. The process fluid is heated by the use of heat exchangers, as shown in Fig. B-1.

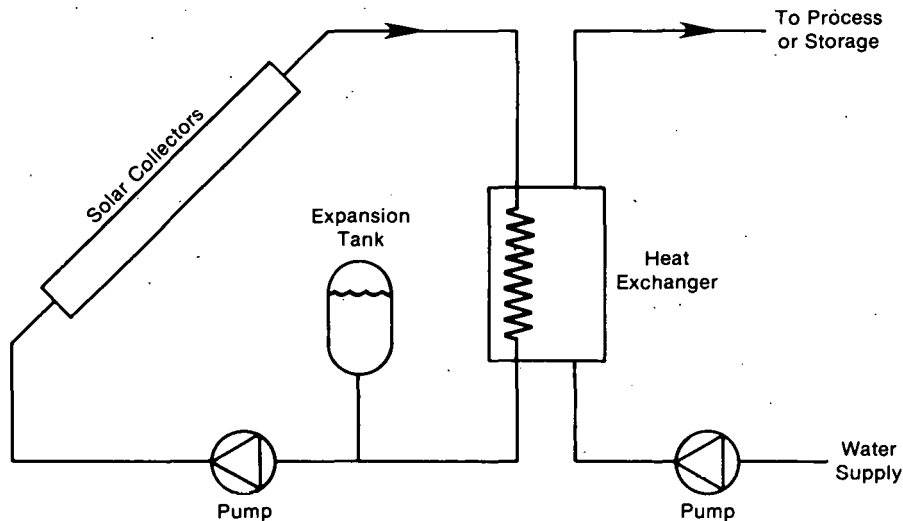

Figure B-1. Closed Loop System Configuration for Heating Water

Diffuse Radiation—Solar energy that is scattered by air molecules, dust, or water droplets before reaching the ground and is not capable of being focused.

Direct Radiation—Solar radiation received that is not scattered by dust or water in the atmosphere.

Double-Walled Heat Exchanger—A heat exchanger designed so that the fluid being heated and the fluid being cooled are separated by two physical walls to prevent their mixing. An intermediate fluid is used to transfer the heat between the two walls, as shown in Fig. B-2. They are primarily used to avoid contamination of one fluid (usually potable water) by another fluid (usually a toxic heat transfer oil).

Drain-Back System—A collector piping system designed so that the fluid in the collector loop drains into a storage tank for freeze protection or to reduce night-time thermal losses from the fluid inventory.

Drain-Down System—A collector piping system designed so that the fluid in the collector loop (normally water) is drained and discarded for freeze protection. Such a system is diagrammed in Fig. B-3.

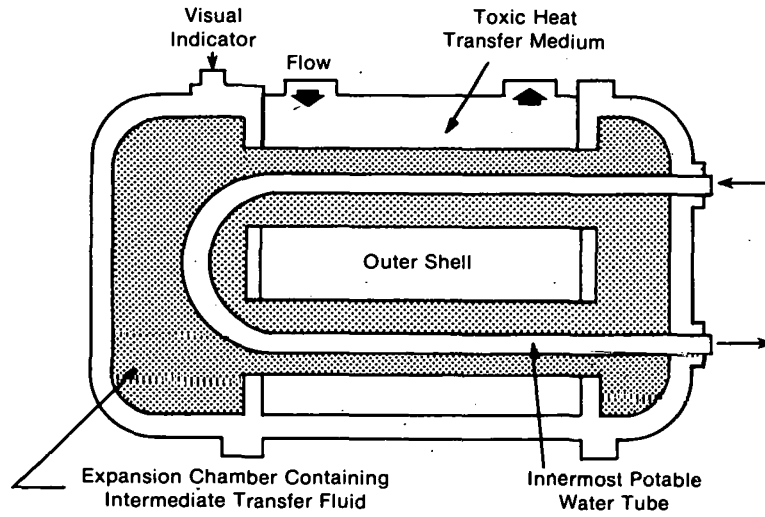

Figure B-2. Example of a Double-Walled Heat Exchanger

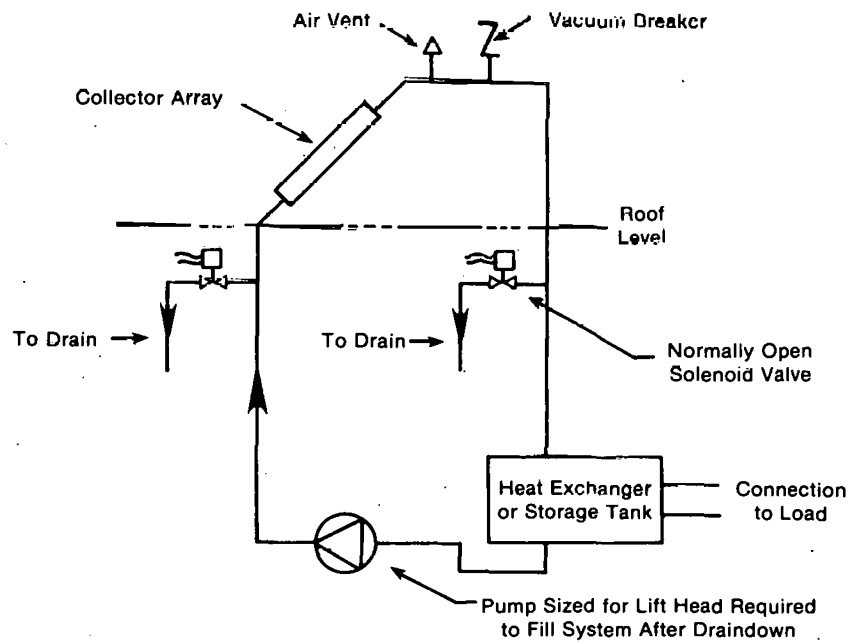

Figure B-3. Typical Drain-Down System

Evacuated Tube Collector—A solar collector in which the absorber is contained within a glass envelope (usually in the form of two concentric cylinders sealed together at one or both ends), and the envelope is evacuated of air to eliminate convection heat transfer. Normally several such tubes are contained in a collector module. An example is pictured in Fig. B-4.

Flat-Plate Collector—A solar collector consisting of a flat, black absorber plate of metal or other suitable material insulated on the bottom and edges and covered by one or more transparent covers. Heat is removed from the collector by air or liquid that is circulated through or around the absorber plate. (See Fig. B-5.)

Incident Angle Modifier—The factor by which the y-intercept of the instantaneous solar noon efficiency curve of a solar collector is multiplied in order to account for the angle of incidence of the sunlight on the collector in a calculation.

Industrial Process Heat—Thermal energy used in an industrial process, usually in the form of heated air or liquid, steam, or radiant heat.

Life-Cycle Cost—An analysis that considers the total relevant costs over the life of a system, including acquisition, maintenance, operation, and disposal. It is used in comparison of design and ownership alternatives and compares the present worth of all future costs.

Linear Concentrator Collector—A solar collector in which the sunlight is focused either by reflectors or other optical devices onto a linear absorber smaller in surface area than the aperture. Since these collectors involve optical concentration of the sunlight, they must track the sun in order to keep the focused sunlight on the absorber and utilize only the direct component of sunlight.

Open Loop—A system configuration in which the process fluid is heated directly in the collectors before being delivered to the industrial process, as shown in Fig. B-6.

Outgassing—The process by which materials and components expel gases.

Parabolic Trough Collector—A linear concentrating collector in which the concentration is done by a parabolic reflector. An example is pictured in Fig. B-7.

Pyranometer—An instrument for measuring the total irradiance (direct and diffuse) on a flat surface.

Pyrheliometer—An instrument for measuring the direct normal component of solar irradiance.

Shadow Band—A device that is used on a pyranometer to block out the direct solar irradiance so that the diffuse component of irradiance can be measured.

Solar Access—The concept of a legal "right-to-sunshine" similar in principle to easements, etc., in civil law, currently under development for solar energy.

Solar-Load Interface—The location at which the solar energy is supplied to the industrial process.

Stagnation—The condition in which a collector is allowed to be in a sun-facing position with no coolant flow. Temperatures reached in stagnation are much higher than normal operating temperatures, especially in the cases of evacuated tube collectors and concentrating collectors.

Thermosiphon—The process of natural circulation of a fluid in a loop due to density variations of the fluid resulting from temperature difference.

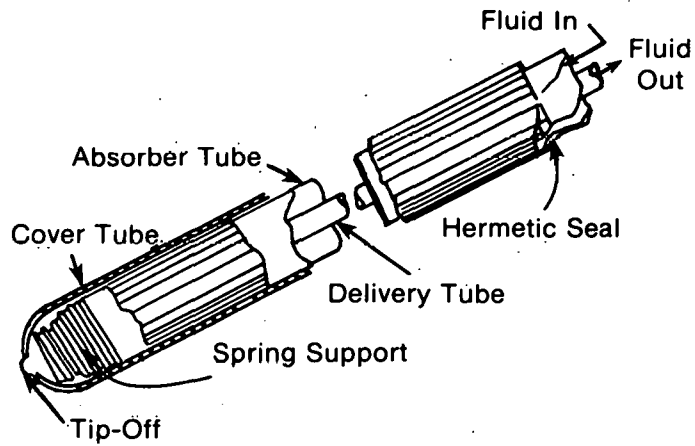

Figure B-4. Concentric Glass Evacuated Tube Collector

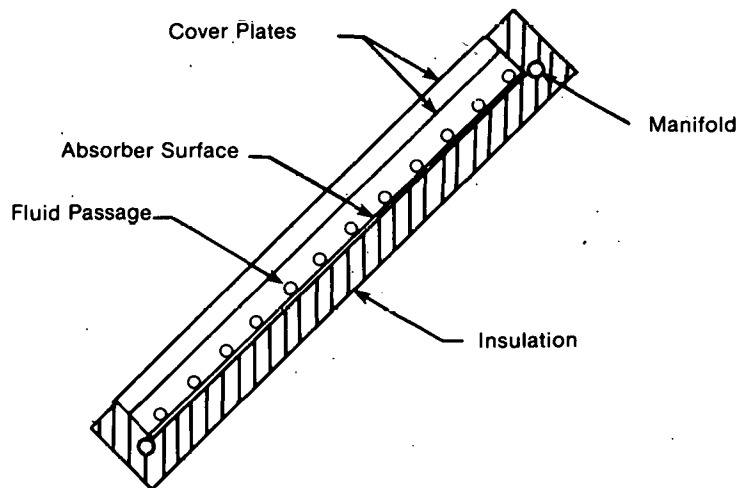

Figure B-5. Flat-Plate Collector (Liquid Type)

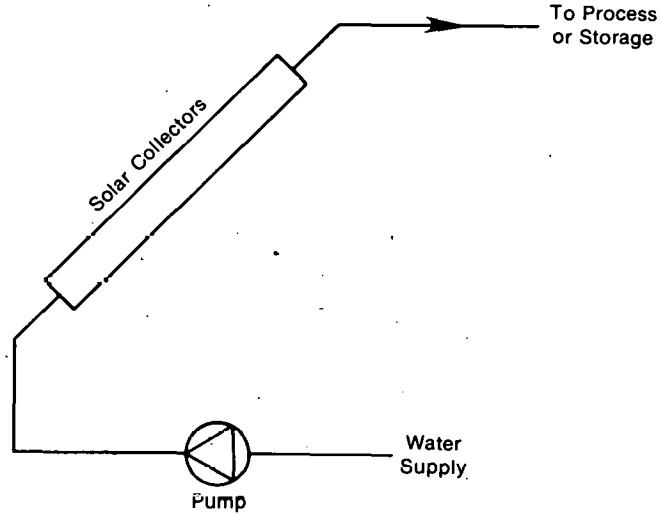

Figure B-6. Open Loop System Configuration for Heating Water.

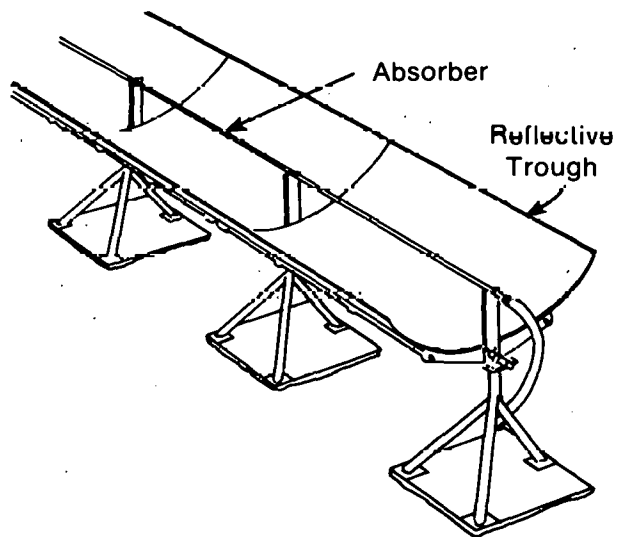

Figure B-7. Parabolic Trough Collector

Document Control Page	1. SERI Report No. TR-632-783	2. NTIS Accession No.	3. Recipient's Accession No.
4. Title and Subtitle Design Considerations for Solar Industrial Process Heat Systems		5. Publication Date March 1981	
7. Author(s) Charles F. Kutscher		8. Performing Organization Rept. No.	
9. Performing Organization Name and Address Solar Energy Research Institute 1617 Cole Boulevard Golden, Colorado 80401		10. Project/Task/Work Unit No. 1011.00	
		11. Contract (C) or Grant (G) No. (C) (G)	
12. Sponsoring Organization Name and Address		13. Type of Report & Period Covered Technical Report	
15. Supplementary Notes		14.	
16. Abstract (Limit: 200 words) This document lists items that should be considered in each aspect of the design of a solar industrial process heat system. These design considerations are based on information obtained from the design and operation of the U.S. Department of Energy (DOE) solar industrial process heat field tests. The collector technologies covered are flat-plate, evacuated tube, and line focus, since these systems have been employed to date in the DOE field test program. This document should be highly informative to the designer lacking solar system experience, since a glossary of technical terms used in the report is included. This document is also a useful checklist for experienced solar system designers. Since the application of solar energy to industrial thermal processes is still a rapidly evolving technology, this document stresses qualitative design considerations rather than specific design recommendations. The design engineer utilizing this report can avoid many of the problems that have occurred in previous projects, although detailed calculations will still be needed to ensure a successful system. However, to aid this effort, an appendix listing further sources of information is included in the report.			
17. Document Analysis a. Descriptors Design ; Evacuated Tube Collectors ; Field Tests ; Flat Plate Collectors ; Operation ; Process Heat ; Energy ; Evacuated Collectors ; Heat ; Solar Collectors ; Industrial Process Heat ; Technology b. Identifiers/Open-Ended Terms c. UC Categories 59b, 62			
18. Availability Statement National Technical Information Service U.S. Department of Commerce 5285 Port Royal Road Springfield, Virginia 22161		19. No. of Pages 54	
		20. Price \$5.25	